

S^{III} SPEEDMASTER™

EST. 1979

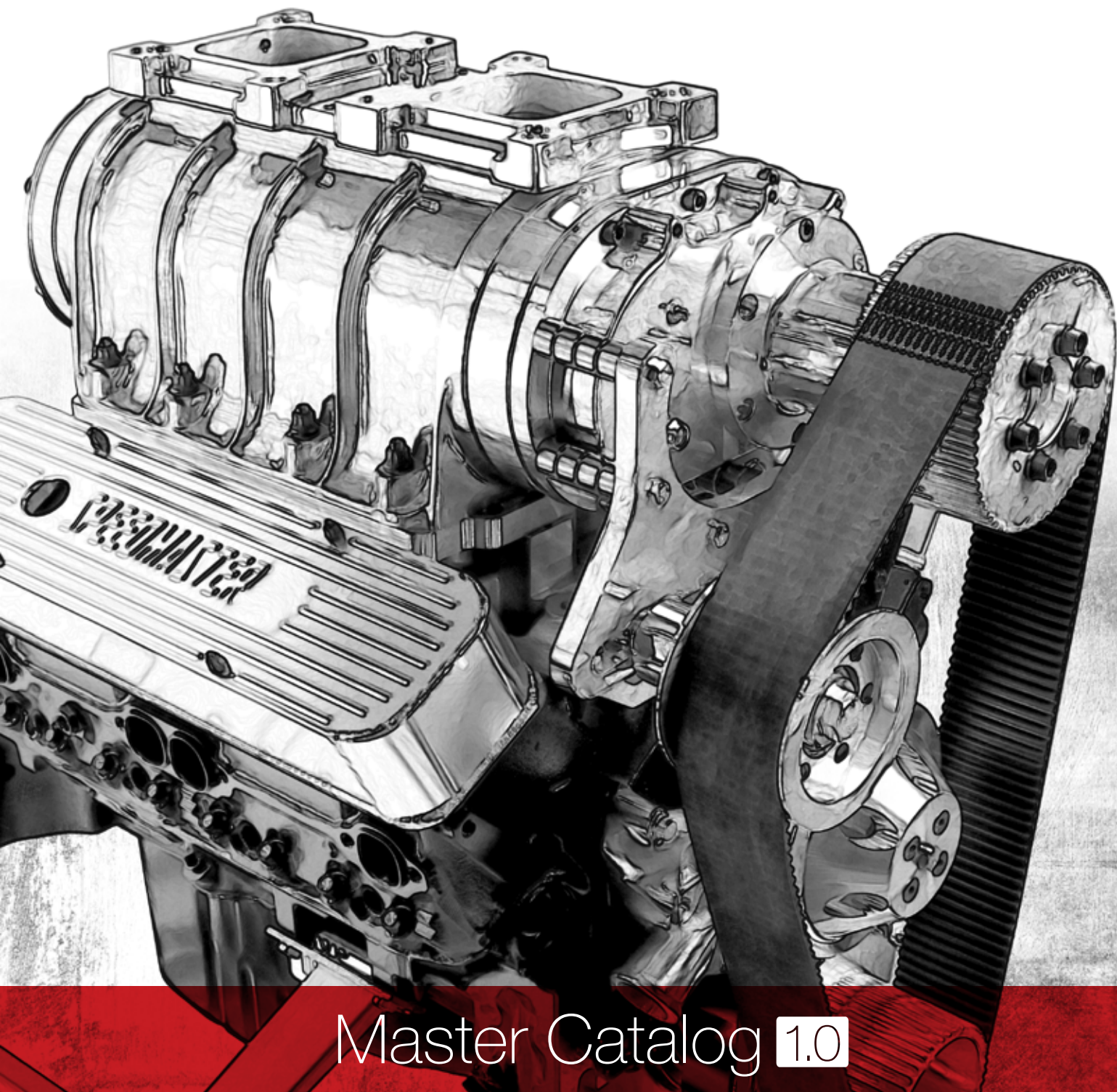

Master Catalog 1.0



FROM RADIATOR TO REAR END

Prices you can afford

Speedmaster™ prides itself on offering the products you want, for the best prices. As a manufacturer and powerhouse we are able to bypass the agents, importers, wholesalers, distributors and retailers that are usually part of the retail process. By cutting out these expensive middlemen, we can pass the savings on to you, where they belong!

Traditional Process

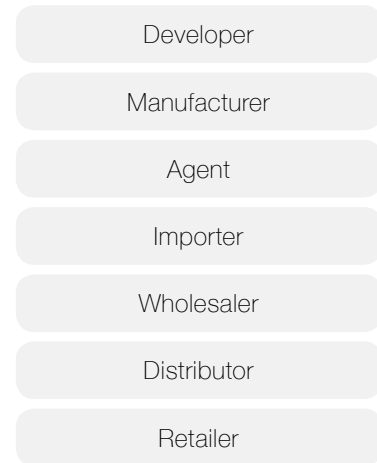

Our Process



Our Vision

To become the most **Customer-Centric** and **Experience-Based** company within the aftermarket automotive industry and to be able to make the industry **enjoyable** for the organizations, employees and consumers.

Top-down philosophy

At Speedmaster we have a top-down philosophy. We use the same development process for making parts in which we use to race in the group one categories, such as Top Fuel Dragsters, to every-day street drivers. We understand that for each application there is a different purpose for each product, but through the production process we make sure we follow the same total quality control to that of the Top Fuel Drag Racing team. By competing in different categories in motorsport we are then able to understand different design purposes and bring them forward to the end-user.

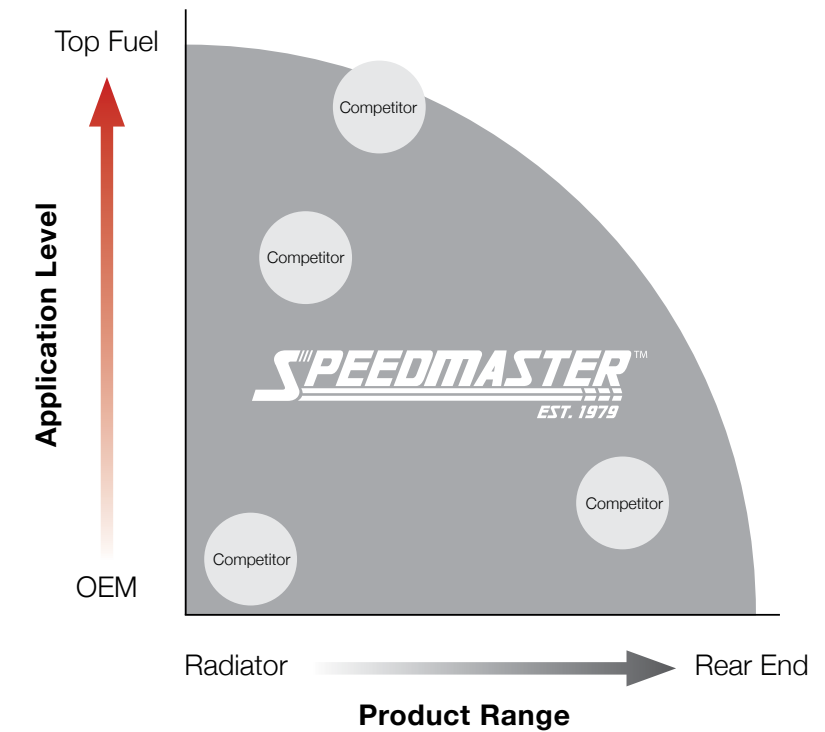

Great customer service

Need Help? The Speedmaster™ website boasts the new Support Centre. Knowledge sharing, FAQ's, Discussion boards, Q&A, New help ticket system, the ability to post a public question and if that isn't enough we also have live chat on our website. If a consumer is working on their car late and can't figure something out; do not worry, Speedmaster™ is online and ready to help.

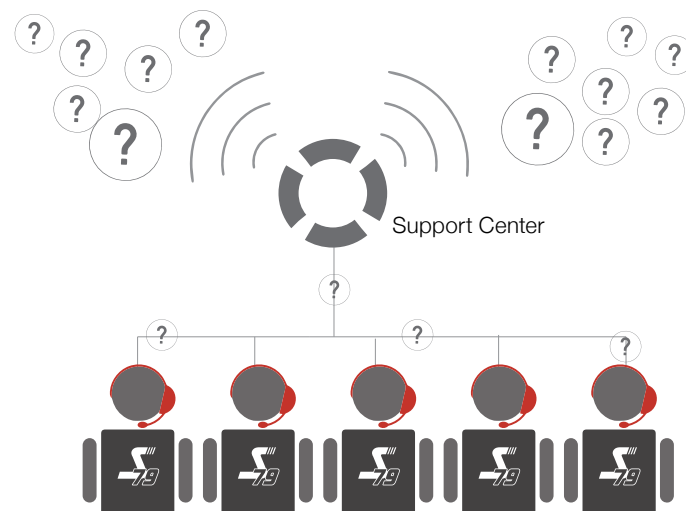

Take a look at our new website



Free USA & Australia local shipping excluding bulk orders over 100 pounds.



We offer international shipping to almost all parts of the world.



SPEEDMASTER Online Store
Visit our store for the latest products and exclusive offers.



SPEEDMASTER My Application
Can't find what you looking for? Just tell us more about your application and our system will find the parts for you!



SPEEDMASTER Support Center
Customer Service is our priority, visit our support center for further assistance. Here you are able to submit Help Tickets, post public questions, watch video tutorials or read our articles.



SPEEDMASTER Live Chat
Chat directly with a Speedmaster support specialist for immediate answers to your questions.



SPEEDMASTER Tools
Our handy tools and calculators will assist you during the engine building process.



SPEEDMASTER Blog
Visit our blog for the latest News.



SPEEDMASTER Media Room
Our Media Room keeps you updated to everything going on in the automotive industry



SPEEDMASTER Video Tutorials
Everything you need to know in simple instructional videos



Not sure which items suit your application?

With five clicks in the my application tool we are able to filter out the entire store for parts relating to your project.

The screenshot displays the 'Speedmaster™ My Application' web interface. At the top left is the logo, which consists of a grid of black squares with a few red ones, followed by the text 'Speedmaster™ My Application'. The main content area features a detailed technical drawing of a car's engine and chassis, with the engine block highlighted in red. Below the drawing is a horizontal navigation bar with eight icons: a pulse line, a key, a hose, a light bulb, a battery, a spray nozzle, a wrench, and an engine. The second icon, the key, is highlighted with a red border and a hand cursor, with a handwritten arrow labeled 'Step 1' pointing to it. To the right of the main area is a sidebar with three dropdown menus and a red 'Submit' button. Handwritten arrows indicate the following steps: 'Step 2' points to the 'Your Engine Make' dropdown (set to 'Chevrolet'), 'Step 3' points to the 'Your Engine Size' dropdown (set to '5.7L / 350'), 'Step 4' points to the 'Your Location' dropdown (set to 'America (NT - ST)'), and 'Step 5' points to the 'Submit' button.

Speedmaster™
My Application

Your Engine Make
Chevrolet

Your Engine Size
5.7L / 350

Your Location
America (NT - ST)

Submit

Step 1

Step 2

Step 3

Step 4

Step 5

Company Overview



In 1979, the company was founded with Pete's Performance, which was a small speed workshop.

It began by building engines for customers as a hobby, and it has now grown to include selling, assembling, manufacturing and racing high performance engine parts.

Over the years, the company has grown into a worldwide high performance powerhouse. Growing from a one-man bricks-and-mortar business; to now a supply chain in which entails more than +500 people all across the world. Today, Pete's Performance has evolved into the internationally known Speedmaster™: which has two major distribution centres; which are Sydney Speed Supplies Pty Ltd. located in Australia, and Procomp Electronics Inc. which is located in the United States of America.

Shake on It

Speedmaster back up every sale with our Handshake Guarantee: If our customers are not satisfied with our products or our service, we will refund their money; no ifs, ands, or buts. Just return any new or unused part within the Speedmaster Limited warranty of the shipping date and we will refund the purchase price.

Kick Goals

Our Goals are. Become the most experience-based' company. Create an engaged and innovative workforce. Be agile and ahead of technological changes. Break as many records as possible; both on and off the track.

Supply & Demand

Speedmaster has two major distribution centres. One in California USA and one in Sydney AUS. In Rialto California, Procomp Electronics is the sole distributor for all Speedmaster products, boasting a 75,000sq feet facility. In Sydney Australia Speedmaster is distributed by Sydney Speed Supplies. With having two solid distribution centres located globally, delivering any package to any part of the world can be done easily and efficiently.

Size Does Matter

Over \$16 million in parts inventory, over 5,000 part numbers: and warehouse in California that allow us to ship to over 98% of the U.S. in two days or less.

At Speedmaster™ we take quality seriously, setting new industry standards for in-house quality control. Our Engineering and Quality Control staff are dedicated and educated in their craft to ensure that the products we offer are designed and manufactured to the highest specifications in the industry.



Awards Board & Partnerships

On The Track

Off The Track



John Zappia

Speedmaster and John Zappia have partnered in the pursuit of making Australian Top Doorslammer history. John Zappia joined the Speedmaster team in playing a key role both their racing program and product development; with 6 championships in a row, the partnership is growing from strength to strength.



Robert Campisi

Robert Campisi's 632 cubed Ford Mustang has become the fastest car with doors on the planet, pulling a staggering 260Mph quarter mile. Campisi said he "would like to thank Speedmaster for their support. Having provided me with the short engine needed in achieving the multiple national and world records set along the way in achieving my goals".

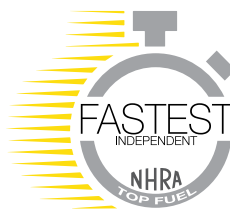

Mike Strasburg

Strasburg Racing operates in both a NHRA Top Fuel Dragster racing team and a high performance machine shop in Utah. Manager of Strasburg racing Lindsay Strasburg said "We really appreciate Speedmaster coming on board with our team, as our machine shop has been using their quality engine products for most of our high performance applications for the last seven years with great success. We're proud to team up with such a fantastic company."



Darren Morgan

Speedmaster™ plays a small role in supporting Darren Morgan Racing in the ANDRA Top Fuel Pro Series Championship. The team and Darren Morgan have won the 2012/2013 ANDRA Pro Series Top Fuel Champion; This is the third consecutive title for Darren Morgan Racing and Darren's personal fourth overall after winning the Top Fuel Championship back in 2004/2005.



Randy Walker

Randy Walker the driver of the World's Fastest El Camino. Best 1/4 ET 6.11 - 1/8 3.98 - Mph 228. 2009 PSCA Pro Street Champion, 2009 WCHRA Pro Street Champion - 2009 Sin City Shootout Champion and the 2009 Golden State Challenge Champion.



Sema Show

The Speedmaster development team have been pushing the boundaries for years; one of the many industry acknowledgements are the 5 in a row SEMA Show Global Media Awards for their research and development of their Pistons, Turnkey EFI system, Manifolds and Water Pumps.



Speedmaster Cares

Speedmaster Cares is our community outreach initiative that addresses important social issues such as education, sustainability and family development, general wellness of people and our future. The Speedmaster team support a range of programs, partners and initiatives that strive to positively impact people, either on a small or worldwide level.

We believe from all small things – big things grow! So the foundation to our support is built from supporting hard working charities which share our vision.



Index

Engine Parts

Bare Engine Blocks	20
Engine Block Expansion Plugs	23
Motor Mounts and Inserts	23
Main Caps	24
Main Cap Girdles	25
Main Cap Fasteners	26
Engine Bearings	27
Main Bearings	27
Rod Bearings	27
Cam Bearings	27
Lifters	28
Camshafts	29
Camshaft Thrust Plates	30
Camshaft Bolts	30
Crankshafts	32
Connecting Rods	38
Connecting Rod Bolts	43
Pistons	44
Piston Rings	47
Engine Rotating Kits	48
Harmonic Balancers	50
Harmonic Balancer Bolts	53
Harmonic Balancer Spacers	53
Timing Tape	53
Timing Systems	54
Chain Drive	54
Gear Drive	54
Belt Drive	54
Timing Components	56
Timing Pointers	56
Timing Covers	56
Timing Cover Fasteners	57
Cylinder Heads	58
Chevrolet Small Block	60
Chevrolet Big Block	64
GM LSx	66
Ford Small Block Windsor	68
Ford Cleveland	70
Ford Big Block	72
Holden	74
Chrysler	76
Oldsmobile	78
Honda & Toyota	78
Chrysler-Hemi	79
Cylinder Head Valvetrain Kits	80
Valvetrain	82
Valves	82
Valve Springs	84
Valve Locks	84
Valve Spring Retainers	85
Valve Spring Shims	85
Valve Spring Locators	85
Valve Stem Seals	85
Lash Caps	86
Guideplates	86
Cylinder Head Components	87
Valve Guides	87
Cylinder Head Fasteners	87
Valve Seats	87
Cylinder Head Bushing Kits	87
Pushrods, Assembled	88
Rocker Arms	90
Valve Covers	98
Valve Cover Baffles	105
Valve Cover Gaskets	105
Valve Covers Accessories	106
Valve Cover Breathers	106
Valve Cover Grommets	106
Valve Cover Fasteners	107
Hold-Down Tabs	107
Oil Fill Caps	107
Pulley Kits	108
Engine Pulley Systems	108
Underdrive Pulley Set	108
Gilmer Drive Kit	109
Alternator Pulleys	110
Power Steering Pulleys	110

Crankshaft Pulleys	111
Water Pump Pulleys	112
Replacement Gilmer Drive Belts	112
Pulley Accessories	113
Alternator Brackets	114
Power Steering Brackets	115
Air Conditioner Brackets	115
Oil Pumps	116
Oil Pump Driveshafts	117
Oil Pans, Individual	118
Oil Pan Fasteners	121
Oil Filters	122
Oil Filter Covers	122
Oil Filter Adapters	122
Engine Oil Dipsticks	123
Oiling System	124
Crankcase Evacuation Systems	124
Oil Filter Mounts	124
Oil Restrictors	124
Oil Pump Pickups	125
Gaskets & Seals	126
Engine Gasket Sets	126
Intake Manifold Gaskets	126
Head Gaskets	127
Oil Pan Gaskets	127
Headers	128
Exhaust Header Gaskets	129
Header Fasteners	129
Radiators	132
Radiator Supports	134
Fluid Coolers	135
Fluid Coolers with Fan	135
Fans, Electric	136
Electric Fan Mounting	137
Fan Switches, Thermal	137
Fan Shrouds	137
Overflow Tanks	138
Catch Cans	138
Coolant Expansion Tank	139
Water Necks	139
Electrical Water Pumps	140
Water Pump Spacers	141
Electric Water Pump, Replacement Components	141
Mechanical Water Pumps	142

Procomp Electronics

Distributors	148
Crank Trigger Kits	161
Distributor accessories	162
Distributor Caps	162
Distributor Coil Covers	163
Distributor Rotors	163
Distributor Cap and Rotor Kits	163
HEI Distributor Upgrade Kits	163
Ignition Components	164
Distributor Replacement Parts	164
Distributor Gears	165
Distributor Hold-Down Clamps	165
Electronic Distributor Conversion Kits	166
RPM Limiters/Selectors	166
Tachometer Adapters	166
Ignition RPM Module Kits	166
Ignition Modules	167
Ignition Boxes	168
Multi-Spark Inductive Ignition	168
Multi-Channel Inductive Ignition	169
6AL CDI Ignition	170
Race CDI Ignition	171
Ignition Coils	172
Spark Plugs	175
Ignition Wire Looms & Separators	176
Battery Boxes	176
Battery Trays	176
Alternators	177
Starters	178
Starter Motor Spacer	179
Starter Motor Shim Kits	179
Wiring Harnesses	181

Air & Fuel Delivery

Intake Manifolds	186
Chevrolet Small Block	190
Chevrolet Big Block	192
Holden	193
Chrysler	193
GM LSx	194
Pontiac	195
Oldsmobile	195
Ford Small Block Windsor	196
Ford Cleveland	198
Ford Big Block	199
Ford Modular	199
Carburetors	200
Throttle Bodies	202
Carburetor Spacers	203
Carburetor Adapters	203
Carburetor Accessories	204
Carburetor Base Plates	204
Carburetor Main Bodies	204
Carburetor Metering Blocks	205
Carburetor Fuel Bowls	205
Carburetor Components	206
Carburetor Stud Kit	206
Carburetor Dust Covers	206
Throttle Cable Brackets	207
Throttle Cables	207
Carburetor Linkage Kits	207
Carburetor Feed Lines	208
Fuel Rails	209
Air Cleaners	210
Air Cleaner Assemblies	212
Air Cleaner Accessories	213
Air Cleaner Studs	213
Air Cleaner Wingnuts	213
Air Cleaner Adapters	213
Air Flow Enhancers	213
Carburetor Scoops	214
OTR Air Intake Kits	214
Nitrous Oxide	215
Nitrous Burst Panel Spacers	215
Nitrous Oxide Plates	215
Nitrous Oxide Bottle Brackets	215
Nitrous Oxide Installation Kit	215
Fuel Cells	216
Fuel Cells Accessories	218
AN Hose	219
Fuel Surge Tanks	219
Fuel Pumps	220
Fuel Pumps Accessories	222
Fuel Pump Mounting Brackets	222
Fuel Pump Block-Off Plates	222
Fuel Pump Mounting Plates	222
Fuel Pump Pushrods	222
Fuel Filters	223
Fuel Filter Replacement Parts	223
Fuel Pressure Regulators	224
Fuel Injectors	225
Supercharger Centrifugal	226
Supercharger Roots Style	227
Supercharger Roots Style Accessories	227
Fittings	228
Hose & Line & Tubing	246

Traction Drive Systems

Axle Assemblies	258
Rear Axle Housings	260
Axle Housing Top Plates	260
Axle Housing Ends	260
Axle Shafts	261
Axle Retainer Plates	261
Wheel Studs	261
Axle Sleeve	261
Third Members	262
Third Member Case	266

Third Member Components	267
Pinion Supports	267
Yokes	267
U-Joint Fasteners	267
Differential Carriers	268
Torque Worm LSD	268
Locker	268
Spools	269
Ring and Pinion Gears	270
Ring Gear Fasteners	270
Ring Gear Spacers	271
Differential & Rear-End Components	272
Differential Carrier Bearings	272
Pinion Bearings	272
Axle Bearings	273
Pinion Seals	273
Pilot Bearings & Circlip	273
Chassis Components	274
Chassis Brackets	274
Suspension Lift Components & Kits	274
Control Arms	275
Spindles	276
Pitman Arms	276
Coil-Over Springs	277
Coil-Over Shock Assemblies	277
Power Steering Pumps	278
Power Steering Reservoirs	278
Steering Boxes	279
Driveshaft Safety Loops	279
Automatic Transmissions	280
Automatic Transmission Pans	281
Flywheels	282
Flexplates	283
Transmission Components	284
Automatic Transmission Shift Kits	284
Kickdown Cables	284
Flywheel Dust Covers	284
Shifters	285
Shifter Components	285
Brake Systems	286
Master Cylinders	286
Brake Boosters	286
Vacuum Pumps, Street	287
Residual Pressure Valves	287

Turnkey EFI

Fuel Injection Systems	292
------------------------	-----

Turnkey Forced Induction

Superchargers Kits	300
--------------------	-----

Crate Motors

Fully-Assembled	308
-----------------	-----

Tools, Accessories & More

Gauges, Analog	314
Power Window Kits	314
Steering Columns	315
Steering Column Shift Arms	315
Piston Ring Compressors	316
Oil Pump Primers	316
Crankshaft Sockets	316
Pushrod Length Checkers	316
Degree Wheels	317
Engine Port Block Off Kits	317
Tire Pressure Gauges	318
Ignition Testers	318
AN Hose End Wrenches	318
Engine Lift Plates	319
Engine Stands	319





Engine Parts

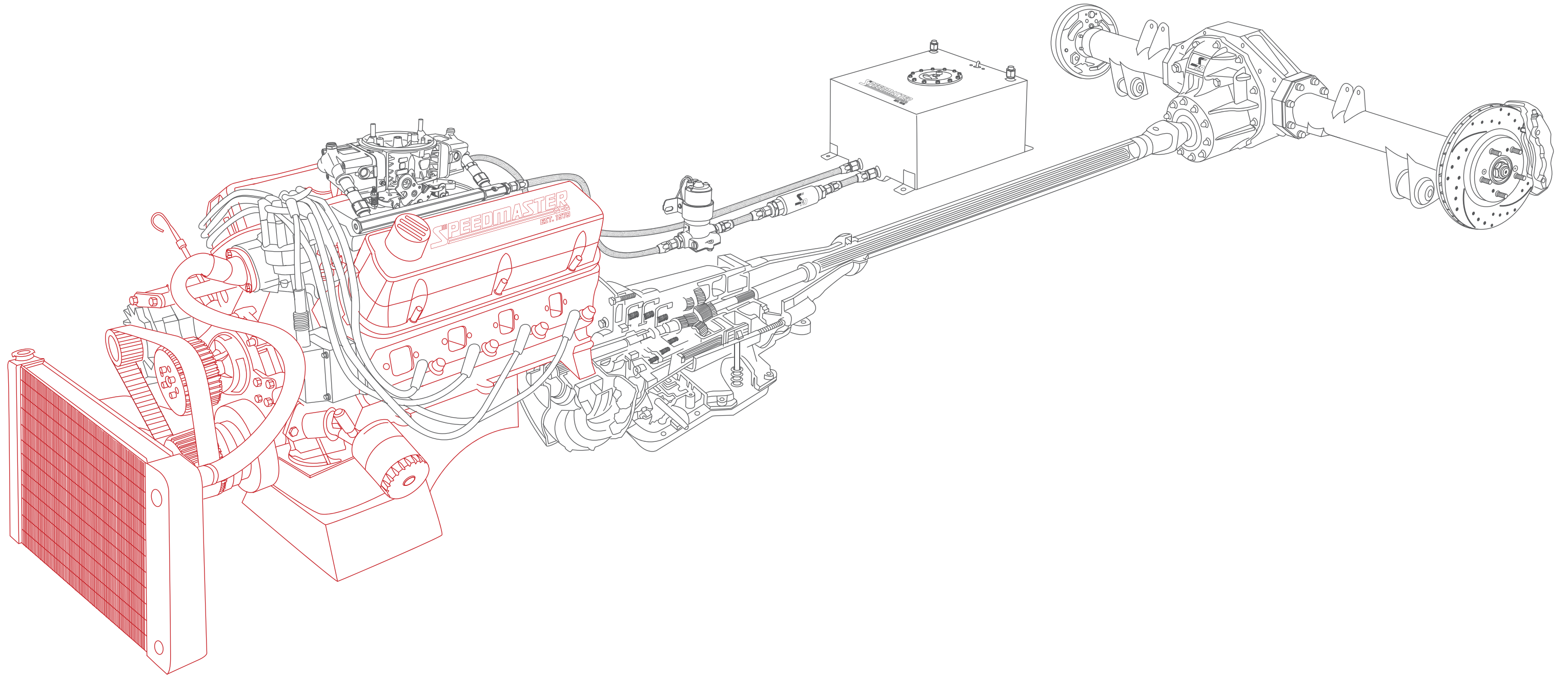

Engine Parts (EP) "Engine Component Related Parts Department"; stands by: providing ongoing proven performance components. This philosophy has been in place since the beginning. With state-of-the-art Manufacturing an extensive research and development program; Speedmaster's commitment to excellence, combined with expert Knowledge and A passion for the high Performance automotive industry has been the result of manufacturing to the highest specifications.

Bare Engine Blocks

Severe Duty

Whether you're building a new engine or recovering from an under-the-hood incident you'd rather soon forget, explore our large selection of aftermarket bare engine blocks to complete your new power plant project. The engine block is the linchpin of vehicles that run on internal combustion, providing the powerhouse for the vehicle. It is called a "block" because it is usually a solid cast car part, housing the cylinders and their components inside a cooled and lubricated crankcase. This part is designed to be extremely strong and sturdy, because its failure results in failure of the car.

The next level of performance are Speedmaster™ cast iron blocks. Designed to look standard under your bonnet, and work with stock components. Our blocks are ready for the street racer with added strength and cubic inches. All the factory flaws redesigned to eliminate all problems, still using water jacket design. Blocks are cast from highest quality high-density iron with extra-thick cylinder walls and decks. In most of our blocks each web is stronger and fitted with billet steel 4-bolt main caps, which are ideal for supercharged, turbocharged and nitrous applications!

- Precision machined from high-nickel cast iron.
- Designed for compatibility with stock components.
- Priority main oil system has been adopted for high hp applications.
- Avail in a range of main tunnel sizes.
- 4 bolt billet steel main caps.*
- Oversized coolant passages for extra cooling for high hp applications.
- Casting reinforced with larger webbing in the valleys and mains to support greater hp.
- 0.250 in. bore size remaining at blocks max recommended bore size.
- High quality 8640 steel bolts supplied.

*Apply for some blocks.



Semi-Finished Unfinished Cylinder Bore

Why waste time sourcing, cleaning, machining, and prepping an old core in hopes it will be usable when you could get a new, quality block without the expense of a full-race unit? Speedmaster™ Semi-Finished Blocks enable you to affordably build a powerful, durable engine. Designed for high-performance and heavy-duty applications producing up to 1500 horsepower, the Semi-Finished Block is an ideal starting point for hot rodders, drag racers, Circle Track competitors, off-roaders, and marine enthusiasts.

Virtually ready to assemble right out of the box after a final cylinder hone.

Fully-Finished Ready-to-Run

Customize an Unfinished block is a great way to get big power out of a little engine, but all of the precision machining involved can get tricky and expensive. Save yourself some time and money--grab one ready-to-run Speedmaster™ Fully-Finished engine block. We've done all of the machining and prep work for you. They also come with installed cam bearings.

This is more than great news for engine builders; it is also a beneficial step for home builders who can now order their block pre-honed.

	Small Block Chevrolet	Big Block Chevrolet	Small Block Ford
Material	High Grade Iron Alloy	High Grade Iron Alloy	High Grade Iron Alloy
Bore	4.00" or 4.125" Unfinished	4.500" Unfinished	4.00" or 4.125" Unfinished
Bore & Stroke	4.185" x 4.000" Max Recommended	4.625" x 4.500" max. recommended	4.185" x 4.250" max recommended
Cam Journal OD	(Cam Tunnel requires grooved 2.000" O.D bearings) Standard SBC - 1.869"	Standard BBC	Standard Ford SB (can be bored for 55mm)
Cam Plug	2.375" dia. cup plug	Standard BBC 2.215" diameter	2.375" dia. cup plug
Cylinder Wall Thickness	.275" min @ 4.185" bore	.300" min @ 4.600" bore	.250" min @ 4.185" bore
Cubic Inch	-	604" max recommended	468 max recommended"
Deck Height	9.025"	9.800"	9.500"
Deck Thickness	.675" min.	Adequate for all applications	.675" min.
Fuel Pump	Mechanical Pump Provision	Mechanical Pump Provision	Mechanical Pump Provision
Fuel Pump Pushrod	Standard Length	Standard BBC	Standard Length
Freeze Plugs	10 x 1 - 5/8 Press in cup plugs	Std press in cup plugs 1 5/8" dia	Std Ford press in cup plugs 1.500" OD
Head Bolts	7/16" Blind Holes	1/2" Blind Holes	1/2" Blind Holes
Lifter Bores	SBC .8427" - .8437"	BBC .8427" - .8437" + .300 Taller Gen V, VI Style	Std Ford .8757" - .8765" Honed to size
Lifters	-	Rollers need tie-bar style lifters	(Can be machined to accept OEM style hyd. roller lifters) Rollers need tie-bar style lifters
Main Journal Size	-	2.937 - 2.938 (std. BBC)	2.749" Std 351 Cleveland
Main Bearing Size	2.450" (350) 2.650" (400)	Std. BBC	2.9415" - 2.9425" Honed to size
Main Bearing Bore	(UF blocks are ~0.010" undersize) 2.649 (350), 2.849 (400)	2.937" - 2.938"	-
Main Thrust Width	-	-	.913" - .915"
Main Cap Bolts	#1 7/16" (2) 3/8" (2) #2, #3, #4 7/16" (2) 7/16" splayed (2) #5 7/16" (2) 3/8" (2)	#1 1/2" (2) 3/8" (2) #2, #3, #4 1/2" (2) 7/16" splayed (2) #5 1/2" (2) 3/8" (2)	#1 1/2" (2) 3/8" (2) #2, #3, #4 1/2" (2) 7/16" splayed (2) #5 1/2" (2) 3/8" (2)
Main Cap Press	.005"	-	.003" - .004"
Main Caps	Steel Billet or Ductile Iron - 4 bolt w/splayed outer bolts on center 3 journals	Steel Billet or Ductile Iron - 4 bolt w/splayed outer bolts on center 3 journals	Steel Billet or Ductile Iron - 4 bolt w/splayed outer bolts on center 3 journals
Main Cap Register	Deep stepped register on each side (no need for dowels)	Deep stepped register on each side (no need for dowels)	Deep stepped register on each side (no need for dowels)
Oil System	Wet Sump - Main Priority Oiling (can use dry sump)	Wet or dry Sump - Main Priority Oiling Priority Main oiling with external pump (wet or dry)	Std Wet Sump or SVO dry sump Priority Main oiling with external pump (wet or dry)
Oil Pump Shaft	350 main = Stock shaft (.481"OD) 400 main = Stock shaft (.425"OD) MUST machine aftermarket shaft	-	-
Oil Filter	Standard SBC filter, uses 2 bolt filter adapter	Stock oil filter location	Standard filter
Oil Pan	Modified STD SBC oil pan	Standard BBC GEN. V bolt pattern	Modified STD 351W oil pan
Rear Main Seal	350 main - std seal / 400 main FelPro# 2909	STD 2 pc seal / Felpro# 2918 or 1 pc seal	Std 1 piece seal FelPro#-2921 or 2942 4.500" x 3.750" SVO
Serial No.	Left front & main caps	On main caps / Front passenger side below deck	Right front & main caps
Starter	Standard SBC	Standard	Standard
Stud Holes, Head	Blind Holes	Blind tapped	1/2" std SVO with blind holes
Timing Chain/Gears	Standard SBC components	Std. BBC Gen IV	Standard Components
Timing Cover	Uses standard cam location SBC front covers	Gen IV / V stock 10 bolt cover	Uses stock 351W cover
Torque Specs	1-5 7/16" bolts - 65 ft lbs 1 & 5 3/8" bolts - 35 ft lbs	All 1/2" bolts - 105 ft lbs	1-5 1/2" bolts - 105 ft lbs 2-4 7/16" bolts - 65 ft lbs 1 & 5 3/8" bolts - 35 ft lbs
Weight	205 lbs at 4.00" bore	4,500" bore 260lbs	208 lbs. at 4.125" Bore



Bare Engine Blocks

Semi-Finished

Application	Main Journal Type	Deck Height (in)	Cylinder Bore Diameter	Main Caps Included	Main Cap Material	Rear Main Seal Style	Finished Cylinder Bores	Cam Bearings Included	SKU
Chevrolet Small Block	350 mains	9.025 in.	4.000 in.	Yes	Billet	STD - 350	No	No	PCE286.1001
			4.125 in.						PCE286.1005
Chevrolet Big Block	454 mains	9.800 in.	4.500 in.	Yes	Billet	1-piece 2-piece	No	No	PCE286.1018
									PCE286.1021
Ford Small Block	351C mains	9.500 in.	4.000 in.	Yes	Cast	1-piece	No	No	PCE286.1014
					Billet				PCE286.1015
			4.125 in.	Yes	Cast	1-piece	No	No	PCE286.1016
					Billet				PCE286.1017

Fully-Finished

Application	Main Journal Type	Deck Height (in)	Cylinder Bore Diameter	Main Caps Included	Main Cap Material	Rear Main Seal Style	Finished Cylinder Bores	Cam Bearings Included	SKU
Chevrolet Small Block	350 mains	9.025 in.	3.970 in.	Yes	Billet	STD - 350	Yes	Yes	PCE286.1023
			4.000 in.						PCE286.1022
			4.095 in.						PCE286.1024
			4.116 in.						PCE286.1025
			4.125 in.						PCE286.1026
			4.095 in.						PCE286.1027
Chevrolet Big Block	454 mains	9.025 in.	4.125 in.	Yes	Billet	STD - 350	Yes	Yes	PCE286.1028
			4.095 in.						PCE286.1019
			4.500 in.	Yes	Billet	1-piece 2-piece	Yes	Yes	PCE286.1020
			4.125 in.						PCE286.1029
Ford Small Block	351C mains	9.500 in.	4.000 in.	Yes	Billet	1-piece	Yes	Yes	PCE286.1030
			4.125 in.						PCE286.1031
				Yes	Billet	1-piece	Yes	Yes	PCE286.1032

Engine Block Expansion Plugs

Speedmaster™ freeze plugs will not rot out, like lower cost steel ones. Your new engine assembly deserves the best. Don't get stuck trying to replace a leaking steel freeze plug behind a motor mount a year or two from now! These kits include all of the necessary external block freeze plugs, and cam and oil galley plugs for one complete engine.

Application	Notes	SKU
Chevy SBC 350	Speedmaster™ Block	PCE285.1001
	-	PCE285.1005
Chevy 400	-	PCE285.1006
Chevy BBC 454	Speedmaster™ Block	PCE285.1003
	-	PCE285.1007
Holden 253 304 308	-	PCE285.1014
Ford SB 289 302 351 Windsor	-	PCE285.1011
Ford 351W Windsor	Speedmaster™ Block	PCE285.1002
Ford 302 351C Cleveland	-	PCE285.1010
Ford FE 332 428	-	PCE285.1013
Ford BB 429 460	-	PCE285.1012
Mopar Chrysler SB 318 340 360	-	PCE285.1008
Mopar Chrysler BB 383 440	-	PCE285.1009



Motor Mounts and Inserts

When swapping out the engine in your hot rod, you need motor mounts that you can count on. Speedmaster™ has done all of the work for you in making these engine swap motor mounts. They're specifically designed for your application, so you can be assured of a perfect fit and great performance. This will convert your holden to take a chevy engine!

PCE169.1001 Chevy SBC 350 to Holden HQ WB LH LX VB VS Commodore

PCE169.1002 Ford Engine Mount Safety Lock Brackets



Main Caps

Speedmaster™ billet main caps are precision CNC-machined from superior-quality 1025 billet steel. They come available as stock replacements (straight bolt) or with splayed outer bolt holes. The splayed caps feature 10 degree angled outer holes to positively reinforce and tie the block together. These extreme main cap sets consist of the center three caps. Speedmaster™ billet main caps improve reliability in highly stressed engines by reducing distortion of the main bearing bores, and increasing the cap's resistance to closing up under high loads. Line boring is required after fitting to the engine.



Application	Main Cap Position	Fastener Quantity	Fastener Style	SKU
	3-center	4-bolt	OEM Replacement	PCE289.1001
Chevrolet SBC 350	3-center	4-bolt	Angled	PCE289.1002
	3-center	4-bolt	Straight	PCE289.1003
Chevrolet 400	3-center	4-bolt	Angled	PCE289.1004
Chevrolet BBC 454	4-center	4-bolt	OEM Replacement	PCE289.1005
	4-center	4-bolt	Straight	PCE289.1006
Holden 253 304 308	3-center	4-bolt	Straight	PCE289.1015
	3-center	4-bolt	Angled	PCE289.1016
Ford SB 289 302 Windsor	3-center	2-bolt	OEM Replacement	PCE289.1007
	3-center	4-bolt	Angled	PCE289.1008
Ford 351 Windsor	3-center	4-bolt	Angled	PCE289.1009
	3-center	4-bolt	Straight	PCE289.1010
Ford 302 351C Cleveland	3-center	4-bolt	Straight	PCE289.1014
Ford 429 460	3-center	4-bolt	Angled	PCE289.1011
Mopar Chrysler BB 440	3-center	2-bolt	OEM Replacement	PCE289.1012
Pontiac 326 400 455	3-center	4-bolt	Angled	PCE289.1013

Splayed outer 4-Bolts Main Caps

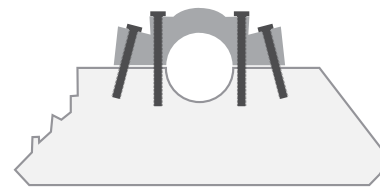

Straight 4-Bolts Main Caps

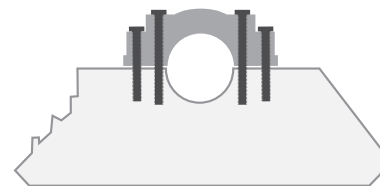

Main Cap Girdles

The forces of higher rpm and power-adders can overwhelm main bearing caps and fasteners, causing the caps to walk, fastener threads to fatigue, and your main web to crack! Speedmaster™ main cap girdles dampen the harmonics that caused the main caps to move in the first place and effectively tie all five main caps together for enough brawn to produce big horsepower capabilities with a stock block! Speedmaster™ has designed these main cap girdles to reinforce the alignment of the main caps in high performance applications and counter the limited webbing and weaknesses of those stock blocks.



Billet Aluminum

Speedmaster™ alloy main girdles are machined from 6061 T6 billet aluminum that creates an additional main web structure to strengthen your block's main webbing. The main girdles are anodized for good looks and durability.



Steel

Speedmaster™ billet steel main girdles are machined from 1045 steel. Flat surfaces are finished with CNC machine center for accuracy and smoothness. The main girdles are zinc plated for rust resistance.

Application	Girdle Material	Girdle Finish	SKU
Chevrolet SBC 350	Steel	Zinc plated	PCE288.1004
	Billet aluminum	Red anodized	PCE288.1005
Chevrolet 400	Steel	Zinc plated	PCE288.1008
	Billet aluminum	Red anodized	PCE288.1009
Chevrolet BBC 454	Steel	Zinc plated	PCE288.1010
	Billet aluminum	Red anodized	PCE288.1011
Holden 253 304 308	Steel	Zinc plated	PCE288.1001
	Billet aluminum	Red anodized	PCE288.1002
GM LS1	Steel	Zinc plated	PCE288.1006
	Billet aluminum	Red anodized	PCE288.1007
Ford SB 289 302 Windsor	Steel	Zinc plated	PCE288.1012
	Billet aluminum	Blue anodized	PCE288.1013
Ford 351W Windsor	Steel	Zinc plated	PCE288.1014
	Billet aluminum	Blue anodized	PCE288.1015
Ford 302 351C Cleveland	Steel	Natural	PCE288.1020
	Billet aluminum	Red anodized	PCE288.1021
Ford 429 460	Steel	Zinc plated	PCE288.1016
	Billet aluminum	Blue anodized	PCE288.1017
Mopar Chrysler BB 383 440	Steel	Zinc plated	PCE288.1018
	Billet aluminum	Red anodized	PCE288.1019



Main Cap Fasteners

Studs

Speedmaster™ main studs are premium-grade, race-quality studs that are created from aircraft quality 8740 high tensile strength chromoly steel, withstanding up to 190,000 PSI. They are ground and thread-rolled after heat treatment to ensure the exacting tolerances that Speedmaster™ requires for all of their fasteners. This ensures strength and consistent torque readings. All kits come complete with 4130 heat-treated, parallel-ground washers and high-strength 12-point nuts.



Bolts

Speedmaster™ main bolt kits are priced low, but their quality is extremely high. These high performance bolts are rated at a hefty 180,000 psi tensile strength and they have a wide-area flange to provide even load distribution during torquing. That's a combination that will get the job done for you.



Application	Fastener Style	Main Bolt Style	Head/Nut Style	Fastener Yield Strength (psi)	Nuts Included	Washers Included	SKU
Chevrolet SBC 350	Bolt	2-bolt	Hex	150,000 psi	No	Yes	PCE287.1019
	Stud	2-bolt	12-point	190,000 psi	Yes	Yes	PCE287.1001
		4-bolt					PCE287.1002
Chevrolet BBC 454	Bolt	2-bolt	Hex	150,000 psi	No	Yes	PCE287.1020
	Stud	2-bolt	12-point	190,000 psi	Yes	Yes	PCE287.1003
		4-bolt					PCE287.1004
GM LS1 LS2 LS6 LS7 LSX GEN III	Stud	4-bolt	12-point	190,000 psi	Yes	Yes	PCE287.1024
Holden 186 202	Stud	2-bolt	12-point	190,000 psi	Yes	Yes	PCE287.1015
Holden 253 304 308	Stud	2-bolt					PCE287.1016
		2-bolt (Main Girdle)	12-point	190,000 psi	Yes	Yes	PCE287.1017
		4-bolt					PCE287.1018
Ford 250 6 Cylinder	Stud	2-bolt	12-point	190,000 psi	Yes	Yes	PCE287.1005
Ford 302 351C Cleveland	Stud	2-bolt	12-point	190,000 psi	Yes	Yes	PCE287.1008
		2-bolt (Main Girdle)					PCE287.1010
Ford 351W Windsor	Stud & Bolt	4-bolt	12-point	190,000 psi	Yes	Yes	PCE287.1009
	Bolt		Hex	150,000 psi	No		PCE287.1022
Ford 429 460	Stud	2-bolt	12-point	190,000 psi	Yes	Yes	PCE287.1007
	Bolt		Hex	150,000 psi	No	Yes	PCE287.1023
Ford SB 289 302 Windsor	Stud	2-bolt	12-point	190,000 psi	Yes	Yes	PCE287.1011
	Bolt		Hex	150,000 psi	No		PCE287.1021
Chrysler 260	Stud	2-bolt	12-point	190,000 psi	Yes	Yes	PCE287.1006
Mopar Chrysler BB 383 440	Stud	2-bolt	12-point	190,000 psi	Yes	Yes	PCE287.1012
Mopar Chrysler SB 318 340 360	Stud	2-bolt	12-point	190,000 psi	Yes	Yes	PCE287.1014
							PCE287.1013

Engine Bearings

Speedmaster™ bearings are just what you need to freshen up your engine. They use silicon aluminum bi-metal construction. Silicon aluminum is the choice for many of today's engine manufacturers because of its high fatigue strength and superior temperature threshold. Bearing wear is dramatically reduced and the fatigue strength is greatly improved.

Main Bearings



Rod Bearings



Cam Bearings



Application	Crankshaft Undersize (in)	Main Bearings	Rod Bearings
Chevrolet SBC 350	Stock	PCE235.1005	PCE234.1005
	0.010 in.	PCE235.1001	PCE234.1001
	0.020 in.	PCE235.1002	PCE234.1002
	0.030 in.	PCE235.1003	PCE234.1003
	0.040 in.	PCE235.1004	PCE234.1004
Chevrolet BBC 454	Stock	PCE235.1010	PCE234.1011
	0.010 in.	PCE235.1006	PCE234.1007
	0.020 in.	PCE235.1007	PCE234.1008
	0.030 in.	PCE235.1008	PCE234.1009
	0.040 in.	PCE235.1009	PCE234.1010
Holden 253 304 308	Stock	PCE235.1031	PCE234.1032
	0.010 in.	PCE235.1026	PCE234.1027
	0.020 in.	PCE235.1027	PCE234.1028
	0.030 in.	PCE235.1028	PCE234.1029
	0.040 in.	PCE235.1029	PCE234.1030
	0.050 in.	PCE235.1030	PCE234.1031
	Custom (1.771")	-	PCE234.1033
Ford SB 289 302 Windsor	Stock	PCE235.1015	PCE234.1016
	0.010 in.	PCE235.1011	PCE234.1012
	0.020 in.	PCE235.1012	PCE234.1013
	0.030 in.	PCE235.1013	PCE234.1014
Ford SB 351 Windsor	Stock	PCE235.1020	PCE234.1021
	0.010 in.	PCE235.1016	PCE234.1017
	0.020 in.	PCE235.1017	PCE234.1018
	0.030 in.	PCE235.1018	PCE234.1019
Ford 302 351C Cleveland	Stock	PCE235.1025	PCE234.1026
	0.010 in.	PCE235.1021	PCE234.1022
	0.020 in.	PCE235.1022	PCE234.1023
	0.030 in.	PCE235.1023	PCE234.1024
	0.040 in.	PCE235.1024	PCE234.1025

Application	SKU
Chevrolet SBC 350	PCE236.1001
Chevrolet SBC 350	PCE236.1006
Chevrolet BBC 454	PCE236.1002
Chevrolet BBC 454	PCE236.1007
Holden 253 304 308	PCE236.1005
Ford SB 289 302 351 Windsor	PCE236.1003
Ford SB 351 Windsor	PCE236.1008
Ford 302 351C Cleveland	PCE236.1004



Crankshaft Bearing Installation

When installing the crankshaft bearings (mains or rods) be sure everything is absolutely clean. Clean your hands like a operating room surgeon. The only thing allowed on your hands is clean engine oil. The running oil gap is as small as .0005" to .0015" radial clearance. Something as small as a human hair caught behind the bearing shell can make the bearing bind up on crank journal, or it may reduce the running clearance and starve the bearing of oil flow required for cooling, leading to premature bearing failure. Try to avoid touching the ID of the bearing. If you do touch it, add a dab of clean oil and wipe it out with your finger tip. If you feel anything at all there, clean it and start again.

Lifters

Push, Push & Push

Don't compromise your engine's performance or risk the well being of your valvetrain with inferior lifters! Ensure consistent valve timing, efficient valvetrain operation, and maximum power with top-brand lifters from Speedmaster™. Choose from hydraulic lifters for quiet, maintenance-free performance on the street or shop our selection of mechanical lifters for superior high-rpm performance. We've got flat tappet designs to fit your budget or roller lifters to reduce valvetrain friction and wear. No matter what your vehicle, engine, and budget, we've got everything you need to give your performance a lift!



i 30

Flat Tappet vs. Roller

1. Friction

Sliding frictional forces are higher than rolling frictional forces. Therefore, a roller cam takes less horsepower to turn and generally does not wear out as quickly. An added benefit is that roller tappets do not require replacement when changing cams. And, if "pop-up" solid roller tappets are used, the cam can be swapped without removing the intake manifold.

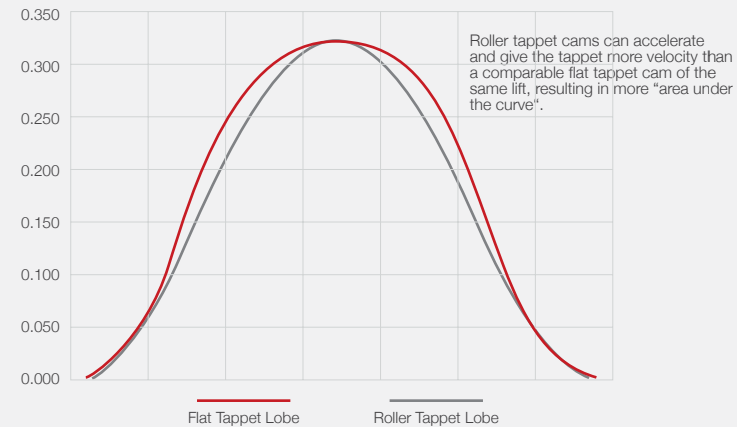

Camshafts

Aggressive Lobe Profile



The heart of the engine is the camshaft, since it is one of the key components that dictates the engine's power level, power band, idle quality, and other characteristics; the camshaft is used to operate poppet valves. It then consists of a cylindrical rod running the length of the cylinder bank with a number of oblong lobes protruding from it, one for each valve. The cam lobes force the valves open by pressing on the valve, or on some intermediate mechanism as they rotate.



i 31

Quick Tip

2. Profile

If a cam profile has more "area under the curve" it has the potential to make more power and torque. Roller profiles can be more "aggressive" and accelerate the tappet more than a flat tappet profile. Flat tappet profiles can only be shaped up to the point where the tappet "digs into" the profile. Roller tappet profiles are not limited by this condition – so much so that even "inverted radius" profiles are possible. This benefits engine performance in two ways: more tappet lift can be achieved without the added duration that would normally be required to "ramp up" a flat tappet to the added lift – making the curve more "pointy;" the lift curve can be made "broader" without increasing lift. Of course, both of these benefits can be combined to create a profile that can easily outperform flat tappet cams.

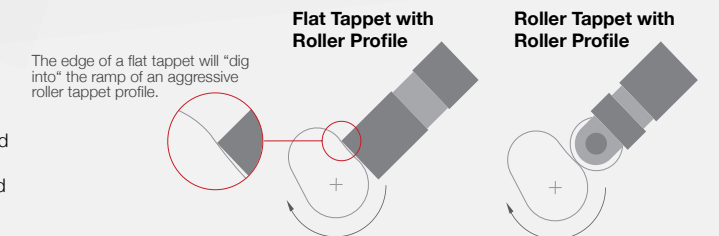

This illustration shows how a flat-tappet lifter will dig into an aggressive roller profile, which is why flat-tappet cams cannot offer the same profile as a roller cam.

3. Cost

Unfortunately, roller camshaft systems cost more than a flat tappet cam and lifters. Much of the added cost is due to the lifters. However, roller tappets can be reused, whereas flat tappets can not. If you tear down your engines frequently, the rollers can be used over and over again, provided they are not damaged or show signs of wear.

Hydraulic Flat Tappet

Hydraulic flat tappets are self-adjusting due to the valve controlled plunger within the tappet body. It operates to pre-load the pushrod by using oil system pressure to maintain this pre-load in the closed valve position. Hydraulic tappets are quieter than solid tappets since there is no lash or free-play. However, it is generally agreed that they fall short of offering optimum performance above 6000-6500 RPM. Many cheaper designs fall even shorter than this. This poor performance at high RPM is due mainly to the inability of the lifter to "bleed down" the excess oil pressure and doesn't allow the valves to seat.

6000 RPM

- Common Usage:** Mild street performance to mild race.
- Key Benefits:** Minimal maintenance, little or no valve train noise and economical cost.
- Limitations:** Long-term wear, limited rpm range, lobe profile limitations.

Hydraulic Roller

The hydraulic roller tappet camshaft can provide the best of both worlds. All Late Model engines have used this design since the mid to late 1980s. They provide most of the virtues of a solid/mechanical roller tappet while providing the benefits of quiet operation and ease of valve lash setting. This type of design still has the limitations of an oil bleed-off control type follower. If your application requires high RPM potential you should use a solid roller design.

7000 RPM

- Common Usage:** Mild street performance to mild race.
- Key Benefits:** Modern, aggressive roller profiles, reduced friction, low maintenance, reduced valve train noise, more power than conventional hydraulic flat tappet camshafts.
- Limitations:** Increased cost, limited rpm range.

Solid/Mechanical Flat Tappet

The solid/mechanical tappet is essentially a solid "link" between the cam lobe and the pushrod. In most cases, it is a simple heat treated cylinder with a radiused contact face. It allows more RPM potential than that of the hydraulic tappet since there are no worries about the inability of the lifter to "bleed down." Solid lifters do, however, require lash or clearance to allow for part expansion as the engine heats up.

8500 RPM

- Common Usage:** Moderate street performance to serious race.
- Key Benefits:** Increased engine rpm and profile aggressiveness vs. economical cost of hydraulic flat tappet.
- Limitations:** Long-term wear, limited rpm range, periodic valve adjustment required.

Solid/Mechanical Roller

The solid/mechanical roller tappet allows for the most aggressive lobe designs. Roller tappets allow faster, "steeper" opening and closing ramps. This allows the cam to produce more lift for a given duration. They are not limited to a particular lifter diameter to obtain higher cam lifts. They also contain a roller that reduces friction between the cam and followers. Roller cams require the use of higher valve spring forces, making high engine speeds (over 10,000 RPM) possible.

10000 RPM

- Common Usage:** Serious street performance to all-out racing.
- Key Benefits:** Maximum performance, reduced friction, most aggressive profiles.
- Limitations:** Increased cost, periodic valve adjustment required, not well suited for extended low rpm operation.

Lifters

Hydraulic Flat Tappet

Application	Lifter Link Bars Included	Link Bar	Lifter Outside Diameter (in)	SKU
Chevrolet SBC 350 Buick & Late Model (*)	No	None	0.842 in.	PCE253.1002
Chevrolet SBC 350 BBC 454, Holden (*)	No	None	0.842 in.	PCE253.1001
Chevrolet SBC 350 BBC 454, Holden	No	None	0.842 in.	PCE253.1003
Ford SB 289 302 351 351C Windsor (*)	No	None	0.874 in.	PCE253.1004
Ford SB 289 302 351 351C Windsor	No	None	0.874 in.	PCE253.1005

(*) Anti-Pump

Hydraulic Roller

Application	Lifter Link Bars Included	Link Bar	Lifter Outside Diameter (in)	SKU
Chevrolet BBC 454	No	OEM	0.842 in.	PCE253.1020
Chevrolet SBC 350	Yes	Vertical	0.842 in.	PCE253.1023
Chevrolet SBC 350, Holden	No	OEM	0.842 in.	PCE253.1008
Holden 253 304 308	Yes	Vertical	0.842 in.	PCE253.1019
Ford SB 289 302 351 Windsor	Yes	Vertical	0.874 in.	PCE253.1021
Mopar Chrysler BB 383 440	Yes	Vertical	0.904 in.	PCE253.1022
Mopar Chrysler SB 318 360	Yes	Vertical	0.904 in.	PCE253.1025
Ford SB 289 302 351 351C Windsor	No	None	0.874 in.	PCE253.1009

Solid/Mechanical Flat Tappet

Application	Lifter Link Bars Included	Link Bar	Lifter Outside Diameter (in)	SKU
Chevrolet SBC 350 BBC 454, Holden	No	None	0.842 in.	PCE253.1006
Chevrolet SBC 350 BBC 454, Holden (**)	No	None	0.842 in.	PCE253.1015
Ford SB 289 302 351 351C Windsor	No	None	0.874 in.	PCE253.1007
Ford SB 289 302 351 351C Windsor (**)	No	None	0.874 in.	PCE253.1016

(**) With Oil Hole

Solid/Mechanical Roller

Application	Lifter Link Bars Included	Link Bar	Lifter Outside Diameter (in)	SKU
Chevrolet SBC 350	Yes	Vertical	0.842 in.	PCE253.1010
Chevrolet BBC 454	Yes	Vertical	0.842 in.	PCE253.1011
Holden 253 304 308	Yes	Vertical	0.842 in.	PCE253.1018
Ford SB 289 302 351 Windsor	Yes	Vertical	0.874 in.	PCE253.1012
Ford 302 351C Cleveland	Yes	Vertical	0.874 in.	PCE253.1017
Ford 429 460	Yes	Vertical	0.874 in.	PCE253.1013
Mopar Chrysler BB 383 440	Yes	Vertical	0.904 in.	PCE253.1014

Camshaft Thrust Plates

Keep your camshaft from wandering with Speedmaster™ camshaft thrust plates. These solid steel plates protect your engine investment by returning your timing back to the desired specifications. Proper positioning of your camshaft is crucial. Includes camshaft thrust plate, fuel pump eccentric and bolts.



PCE510.1001 Holden 253 304 308 355 4.2 5.0 & 5.7 Litre

Camshaft Bolts

Speedmaster™ cam bolts have increased preload clamping force to ensure positive timing gear register. Their increased material strength overcomes valvetrain harmonics and stress. They feature a black oxide finish and 12 point head.



PCE247.1001 Chevrolet SBC 350 BBC 454 Kit

Camshafts

Hydraulic Flat Tappet

Application	Basic RPM	Intake Duration at 050° Lift	Exhaust Duration at 050° Lift	Advertised Intake Duration	Advertised Exhaust Duration	Intake Valve Lift with Factory Rocker Arm Ratio	Exhaust Valve Lift with Factory Rocker Arm Ratio	Lobe Separation (degrees)	SKU
Chevrolet SBC 350	-	227	241	-	-	0.557 in.	0.540 in.	107	PCE249.1007
-	-	230	230	292	292	0.497 in.	0.495 in.	109	PCE249.1020
Holden 304	2,500-6,000	233	233	294	294	0.530 in.	0.530 in.	112	PCE249.1001
-	-	246	246	288	288	0.586 in.	0.586 in.	110	PCE249.1019

Hydraulic Roller

Application	Basic RPM	Intake Duration at 050° Lift	Exhaust Duration at 050° Lift	Advertised Intake Duration	Advertised Exhaust Duration	Intake Valve Lift with Factory Rocker Arm Ratio	Exhaust Valve Lift with Factory Rocker Arm Ratio	Lobe Separation (degrees)	SKU
Chevrolet SBC 350	1,600-5,400	218	224	270	276	0.495 in.	0.502 in.	110	PCE249.1011
	2,500-6,000	236	242	288	294	0.540 in.	0.520 in.	110	PCE249.1021
	2,800-6,100	242	248	294	300	0.540 in.	0.562 in.	110	PCE249.1010
Ford 351 Windsor	3,200-6,200	248	254	300	306	0.562 in.	0.580 in.	110	PCE249.1012
	1,500-5,500	218	224	270	276	0.513 in.	0.513 in.	110	PCE249.1016
	2,000-6,000	230	236	282	289	0.513 in.	0.529 in.	110	PCE249.1015
Ford 302 351 Cleveland	2,200-6,200	236	240	288	294	0.555 in.	0.576 in.	110	PCE249.1017
	2,500-6,500	242	248	294	300	0.576 in.	0.600 in.	110	PCE249.1018
	2,500-6,200	243	257	299	319	0.579 in.	0.563 in.	107	PCE249.1013
Holden 304	3,200-6,800	227	241	283	303	0.557 in.	0.539 in.	107	PCE249.1006
	-	240	251	-	-	0.574 in.	0.590 in.	107	PCE249.1004
GM LS1 LS2 LS6	1,800-6,600	222	225	272	281	0.561 in.	0.578 in.	112	PCE249.1022
	2,000-7,400	226	236	274	285	0.525 in.	0.525 in.	113	PCE249.1023
-	2,000-7,200	226	232	281	284	0.578 in.	0.587 in.	112	PCE249.1024

Solid/Mechanical Flat Tappet

Application	Basic RPM	Intake Duration at 050° Lift	Exhaust Duration at 050° Lift	Advertised Intake Duration	Advertised Exhaust Duration	Intake Valve Lift with Factory Rocker Arm Ratio	Exhaust Valve Lift with Factory Rocker Arm Ratio	Lobe Separation (degrees)	SKU
Ford 302 351 Cleveland	3,000-7,000	260	260	306	306	0.640 in.	0.640 in.	110	PCE249.1014
Holden 304	3,200-6,800	250	257	324	332	0.560 in.	0.580 in.	108	PCE249.1003



Quick Tip

Lift
Lift refers to maximum valve lift. This is how much the valve is "lifted" off its seat at the cam lobe's highest point.

Duration
This is the length of time, measured in crankshaft degrees that the valve is off its seat.

Overlap
The number of crankshaft degree where both the inlet and exhaust valve are open at the same time.

Lobe Separation Angle
The angle between the inlet and exhaust lobe, measured in degrees.

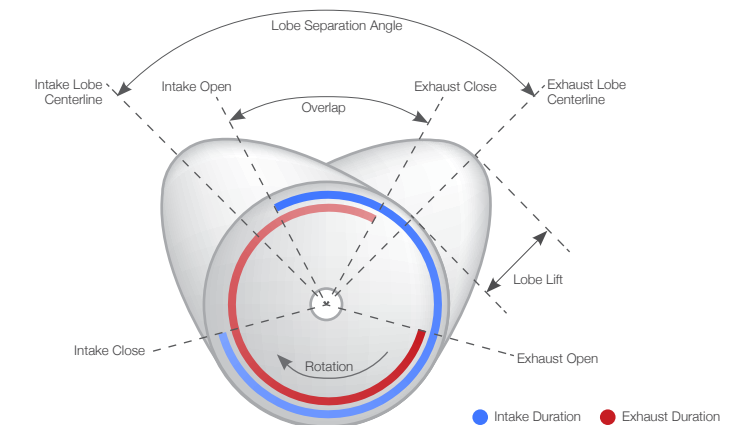

Crankshafts

Brute Force

They say that the heart of the engine is the camshaft, since it is one of the key components that dictates the engine's power level, power band, idle quality, and other characteristics. If the cam is the heart, then the crankshaft is the spine. The crankshaft also dictates power and powerband, but in a much more ambivalent way (through its stroke which, along with the bore size, dictates the engine's cubic-inch displacement). The crank is what transfers the up and down reciprocating movement of the piston and rod into the rotating motion required to drive the transmission. It carries the weight of all eight rods and pistons, and must deal with the shock loads of the combustion process. A stock crank does this fine...in a stock engine. But when power levels start to climb, that stock crank will eventually give under the tremendous loads imposed upon it.



Crankshaft Components

Main Journals – Machined surfaces located at the center of the crankshaft; rotation axis of the crankshaft runs through the center point of the main journals; main journals rotate in the main bearing bore created by the engine block and main caps.

Connecting Rod Journals – Surface to which the connecting rods attach. They circle around the crank's axis of rotation.

Counterweights – Balance the crankshaft to eliminate harmful vibrations. (Check the internal or external balance specifications of the particular crank)

Snout – Extends through the front end of the engine block; the camshaft timing assembly is connected to the snout, as well as the damper/balancer.

Flange – Mounting structure for the flywheel or flexplate.

Tensile strength

The tensile strength is the maximum amount of tensile stress that it can take before failure, for example braking.

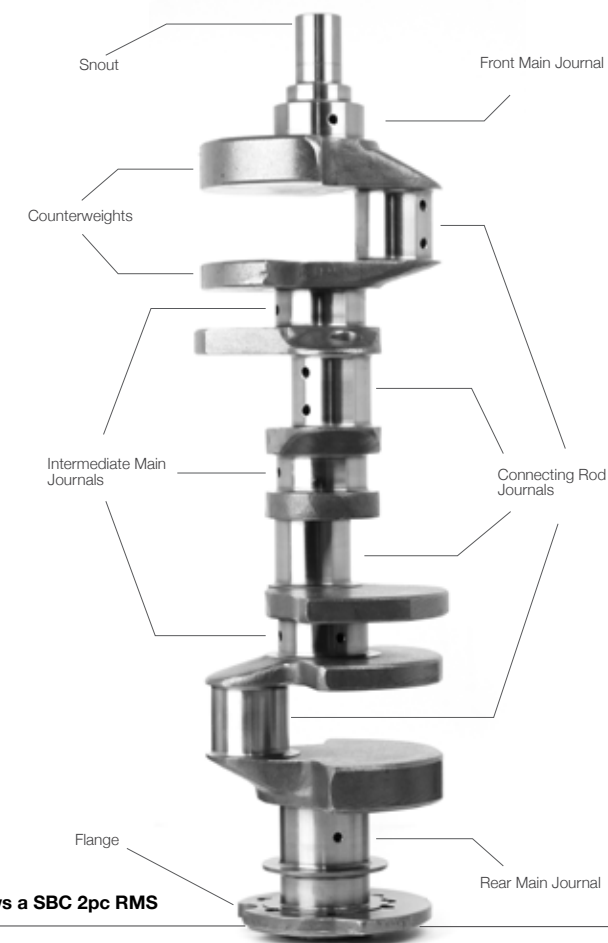

Example shows a SBC 2pc RMS



Cast
Tensile strength 95,000 Psi

Speedmaster™ cast nodular iron crankshafts are perfect for mildly built street engines or just to replace stock crankshafts that have seen better days. These Speedmaster™ crankshafts are precision-ground to exacting tolerances.



Forged-51
Tensile strength 115,000 Psi

Speedmaster™ 5140 forged steel crankshafts are perfect for high compression or blown street applications as well as most race cars. Horsepower ratings should be limited to the 700HP range for maximum efficiency. For the most serious street and racing applications look to the 4340 Series crankshafts. Speedmaster™ crankshafts are precision-ground, heat-treated and inspected for superior tolerance control. Speedmaster™ crankshafts also have straight-shot and chamfered oil holes, and feature lightening holes in all rod throws. These crankshafts also have a large radius on all journals for improved strength and wear resistance

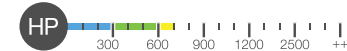

Forged-43
Tensile strength 145,000 Psi

For absolutely serious street and racing applications, a 4340 forged steel Speedmaster™ crankshaft is the only choice. They are perfect for high horsepower, torque and RPM's and work great for all levels of power adders. Horsepower ratings are good for 1000 HP. Speedmaster™ crankshafts are precision-ground, heat-treated, shot-peened and inspected for superior tolerance control. Speedmaster™ crankshafts are also nitride-hardened for superior wear resistance, have straight-shot and chamfered oil holes, and feature lightening holes in all rod throws. These crankshafts also have a large radius on all journals for improved strength and wear resistance

** Feature available in some items within product line

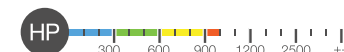

Billet
Tensile strength 162,000 Psi

Billet crankshafts are at the top end of the high-performance crankshaft scale. They are precision CNC-machined from a solid chunk of forged steel on state-of-the-art equipment by master craftsmen for precise indexing and throw-to-throw consistency. The grain structure is not stretched or deformed; This makes for a stronger, stiffer, more durable finished product. Most Pro Race categories run billet cranks. Choose a better made billet crankshaft from Speedmaster™ and choose peace of mind.



Crankshafts

Cast

Application	Engine Stroke (in)	Rear Main Seal Style	Engine Balance	Lightened	Rod Journal Diameter (in)	Rod Width	Main Journal Diameter (in)	Minimum Rod Length (in)	SKU	
Chevrolet SBC 350	3.480 in.	1-piece	Internal	No	2.100 in.	STD	2.449 in.	5.700 in.	PCE276.1086	
		2-piece							PCE276.1085	
	3.750 in.	1-piece	External	No	2.100 in.	STD	2.449 in.	5.700 in.	PCE276.1084	
		2-piece							PCE276.1087	
Chevrolet 400	3.750 in.	2-piece	External	No	2.100 in.	STD	2.649 in.	5.700 in.	PCE276.1083	
Chevrolet BBC 454	4.000 in.	1-piece	External	No	2.200 in.	STD	2.749 in.	6.135 in.	PCE276.1091	
		2-piece							PCE276.1088	
	4.250 in.	1-piece	External	No	2.200 in.	STD	2.749 in.	6.385 in.	PCE276.1090	
		2-piece							PCE276.1089	
Holden 304 308	3.480 in.	Rope	Internal	No	2.125 in.	STD	Standard	5.625 in.	PCE276.1114	
		Rope			2.125 in.	0.940 in.			PCE276.1115	
		Rope			2.100 in.	STD			PCE276.1123	
GM LS1	3.650 in.	Rope	Internal	No	1.900 in.	STD	Standard	5.700 in.	PCE276.1121	
		Rope			1.880 in.	STD			PCE276.1116	
		Standard			2.100 in.	STD			PCE276.1112	
Ford 289 302 5.0L	3.000 in.	1-piece	28 oz. External	No	2.123 in.	STD	2.2486 in.	5.090 in.	PCE276.1092	
		1-piece							2.123 in.	STD
Ford 289 302 5.0L	3.400 in.	1-piece	28/50 oz. External	No	2.123 in.	STD	2.2486 in.	5.400 in.	PCE276.1094	
		1-piece			2.100 in.				PCE276.1095	
		1-piece			2.123 in.				PCE276.1096	
Ford 351 Windsor	3.470 in.	1-piece	28/50 oz. External	No	2.100 in.	STD	2.2486 in.	5.370 in.	PCE276.1097	
		1-piece			2.310 in.				STD	PCE276.1098
		1-piece			2.310 in.				STD	PCE276.1130
Ford 351 Cleveland	3.850 in.	1-piece	28 oz. External	No	2.100 in.	0.940 in.	3.000 in.	6.200 in.	PCE276.1111	
		1-piece			2.100 in.	0.940 in.			PCE276.1108	
		1-piece			2.100 in.	0.940 in.			PCE276.1109	
Ford 429 460	3.500 in.	2-piece	28 oz. External	No	2.100 in.	0.940 in.	2.749 in.	6.000 in.	PCE276.1120	
		2-piece			2.100 in.	0.940 in.			PCE276.1117	
		2-piece			2.100 in.	0.940 in.			PCE276.1118	
Chrysler SB 360	3.850 in.	2-piece	28 oz. External	No	2.100 in.	0.940 in.	2.749 in.	6.125 in.	PCE276.1117	
		2-piece			2.100 in.	0.940 in.			PCE276.1118	
Chrysler BB 361 383 400	4.000 in.	2-piece	28 oz. External	No	2.100 in.	0.940 in.	2.749 in.	6.200 in.	PCE276.1110	
		2-piece			2.100 in.	0.940 in.			PCE276.1111	
Chrysler Hemi RB 426 440	3.850 in.	2-piece	28 oz. External	No	2.100 in.	0.940 in.	2.749 in.	6.200 in.	PCE276.1110	
		2-piece			2.100 in.	0.940 in.			PCE276.1111	
Pontiac 400	4.000 in.	2-piece	Internal	No	2.500 in.	STD	3.000 in.	6.605 in.	PCE276.1099	
		2-piece			2.500 in.	STD			PCE276.1106	
Pontiac 455	4.140 in.	2-piece	Internal	No	2.500 in.	STD	3.000 in.	6.605 in.	PCE276.1106	
		2-piece			2.125 in.	STD			PCE276.1119	
Pontiac 455	4.000 in.	2-piece	Internal	No	2.125 in.	STD	2.810 in.	n/a	PCE276.1119	
		2-piece			2.375 in.	STD			PCE276.1102	
Pontiac 455	4.125 in.	2-piece	Internal	No	2.375 in.	STD	2.750 in.	6.760 in.	PCE276.1103	
		2-piece			2.375 in.	STD			PCE276.1103	
Pontiac 455	3.750 in.	2-piece	Internal	No	2.375 in.	STD	2.750 in.	6.860 in.	PCE276.1100	
		2-piece			2.375 in.	STD			PCE276.1100	
Pontiac 455	4.125 in.	2-piece	Internal	No	2.375 in.	STD	2.750 in.	6.860 in.	PCE276.1101	
		2-piece			2.375 in.	STD			PCE276.1101	
Pontiac 455	4.210 in.	2-piece	Internal	No	2.250 in.	3.000 in.	6.625 in.	6.625 in.	PCE276.1104	
		2-piece			2.250 in.				3.250 in.	6.625 in.

Forged-51

Application	Engine Stroke (in)	Rear Main Seal Style	Engine Balance	Lightened	Rod Journal Diameter (in)	Rod Width	Main Journal Diameter (in)	Minimum Rod Length (in)	SKU
Chevrolet SBC 350	3.480 in.	1-piece	Internal	No	2.100 in.	STD	2.449 in.	5.700 in.	PCE276.1068
		2-piece							PCE276.1067
Chevrolet SBC 350	3.500 in.	2-piece	Internal	No	2.100 in.	STD	2.449 in.	5.700 in.	PCE276.1069
		2-piece							PCE276.1070
Chevrolet SBC 350	3.562 in.	1-piece	Internal	No	2.100 in.	STD	2.449 in.	5.700 in.	PCE276.1125
		2-piece							PCE276.1077
Chevrolet SBC 350	3.750 in.	1-piece	Internal	No	2.100 in.	STD	2.449 in.	6.000 in.	PCE276.1071
		2-piece							PCE276.1072
Chevrolet 400	4.000 in.	2-piece	External	No	2.100 in.	STD	2.649 in.	5.700 in.	PCE276.1074
		2-piece							PCE276.1075
Chevrolet BBC 454	4.000 in.	2-piece	External	No	2.200 in.	STD	2.749 in.	6.135 in.	PCE276.1076
		2-piece							PCE276.1078
Ford 289 302 5.0L	3.000 in.	1-piece	28 oz. External	No	2.123 in.	STD	2.2486 in.	5.090 in.	PCE276.1079
		1-piece							PCE276.1080
Ford 289 302 5.0L	3.250 in.	1-piece	28 oz. External	No	2.123 in.	STD	2.2486 in.	5.315 in.	PCE276.1081
		1-piece							PCE276.1082

More 



Forged-43

Application	Engine Stroke (in)	Rear Main Seal Style	Engine Balance	Lightened	Rod Journal Diameter (in)	Rod Width	Main Journal Diameter (in)	Minimum Rod Length (in)	SKU	
Chevrolet SBC 350	3.480 in.	1-piece		No					PCE276.1019	
		2-piece	Internal	No	2.100 in.	STD	2.449 in.	5.700 in.	PCE276.1009	
		2-piece		Yes					PCE276.1010	
	3.500 in.	2-piece	Internal	No	2.100 in.		2.449 in.	5.700 in.	PCE276.1011	
	3.562 in.	2-piece	Internal	No	2.100 in.	STD	2.449 in.	5.700 in.	PCE276.1012	
	3.625 in.	2-piece	Internal	No	2.100 in.		2.449 in.	5.700 in.	PCE276.1126	
	3.750 in.	1-piece	External	No	2.100 in.	STD	2.449 in.	5.700 in.	PCE276.1020	
			Internal	Yes					PCE276.1021	
		2-piece		No					5.700 in.	PCE276.1014
			Internal	No	2.100 in.	STD	2.449 in.	6.000 in.		PCE276.1013
				Yes					6.000 in.	PCE276.1015
	3.875 in.	2-piece	Internal	No	2.100 in.	STD	2.449 in.	6.000 in.	PCE276.1016	
	4.000 in.	2-piece	Internal	No	2.100 in.	STD	2.449 in.	6.000 in.	PCE276.1017	
				Yes					6.000 in.	PCE276.1018
	Chevrolet 400	3.750 in.	2-piece	External	Yes	2.100 in.	STD	2.649 in.	6.000 in.	PCE276.1025
				No				5.700 in.	PCE276.1022	
3.875 in.		2-piece	External	No	2.100 in.	STD	2.649 in.	6.000 in.	PCE276.1027	
4.000 in.		2-piece	External	Yes	2.100 in.	STD	2.649 in.	6.000 in.	PCE276.1028	
				No					6.000 in.	PCE276.1026
4.250 in.		2-piece	External	Yes	2.100 in.	STD	2.649 in.	6.000 in.	PCE276.1029	
3.766 in.		2-piece	Internal	No	2.200 in.	STD	2.749 in.	6.135 in.	PCE276.1030	
Chevrolet BBC 454	4.000 in.	1-piece	External		2.200 in.	STD	2.749 in.	6.135 in.	PCE276.1036	
		2-piece	Internal	No				6.135 in.	PCE276.1031	
	4.125 in.	2-piece	Internal	Yes	2.200 in.	STD	2.749 in.	6.385 in.	PCE276.1134	
		(8-C) 1-piece	Internal						PCE276.1129	
	4.250 in.	1-piece	External	No	2.200 in.	STD	2.749 in.	6.385 in.	PCE276.1037	
		(8-C) 2-piece	Internal						PCE276.1128	
	4.375 in.	2-piece	Internal						PCE276.1032	
			Yes						PCE276.1135	
	4.500 in.	2-piece	Internal	No	2.200 in.	STD	2.749 in.	6.385 in.	PCE276.1033	
				No					6.385 in.	PCE276.1034
(8-C) 2-piece		Internal						PCE276.1132		
4.750 in.	(8-C) 2-piece	Internal	No	2.200 in.	STD	2.749 in.	6.385 in.	PCE276.1133		
	2-piece							PCE276.1035		
GM LS	4.000 in.	1-piece	Internal	No	2.100 in.	STD	LS Standard	6.098 in.	PCE276.1060	
	4.100 in.	1-piece	Internal	No	2.100 in.	STD	LS Standard	6.098 in.	PCE276.1061	
	4.125 in.	1-piece	Internal	No	2.100 in.	STD	LS Standard	6.098 in.	PCE276.1122	

(8-C) =  8-Counterweight

Forged-43

Application	Engine Stroke (in)	Rear Main Seal Style	Engine Balance	Lightened	Rod Journal Diameter (in)	Rod Width	Main Journal Diameter (in)	Minimum Rod Length (in)	SKU
Ford 289 302 5.0L	3.000 in.	1-piece	28 oz. External	No	2.123 in.	STD	2.2486 in.	5.090 in.	PCE276.1039
									PCE276.1040
	3.250 in.	1-piece	28 oz. External	No	2.123 in.	STD	2.2486 in.	5.315 in.	PCE276.1041
									5.315 in.
	3.400 in.	1-piece	50 oz. External	No	2.123 in.	STD	2.2486 in.	5.400 in.	PCE276.1042
									5.400 in.
3.470 in.	1-piece	28 oz. External	No	2.123 in.	STD	2.2486 in.	5.400 in.	PCE276.1136	
								5.400 in.	PCE276.1044
Ford 351 Windsor	3.500 in.	1-piece	28 oz. External	No	2.310 in.	STD	3.000 in.	5.986 in.	PCE276.1045
	3.750 in.	1-piece	28 oz. External	No	2.310 in.	STD	3.000 in.	5.986 in.	PCE276.1047
	3.850 in.	1-piece	28 oz. External	No	2.310 in.	STD	3.000 in.	5.986 in.	PCE276.1046
									5.986 in.
	4.000 in.	1-piece	28 oz. External	No	2.100 in.	0.940 in.	3.000 in.	6.200 in.	PCE276.1048
	4.100 in.	1-piece	28 oz. External	No	2.100 in.	0.940 in.	3.000 in.	6.200 in.	PCE276.1050
	4.170 in.	1-piece	28 oz. External	No	2.100 in.	0.940 in.	3.000 in.	6.200 in.	PCE276.1050
	3.750 in.	2-piece	28 oz. External	No	2.100 in.	STD	2.749 in.	6.200 in.	PCE276.1062
Ford 351 Cleveland	3.850 in.	2-piece	28 oz. External	No	2.100 in.	STD	2.749 in.	6.200 in.	PCE276.1124
	3.900 in.	2-piece	28 oz. External	No	2.100 in.	STD	2.749 in.	6.200 in.	PCE276.1063
	4.000 in.	2-piece	28 oz. External	No	2.100 in.	STD	2.749 in.	6.200 in.	PCE276.1049
	4.100 in.	2-piece	28 oz. External	No	2.100 in.	STD	2.749 in.	6.200 in.	PCE276.1058
	4.170 in.	2-piece	28 oz. External	No	2.100 in.	STD	2.749 in.	6.200 in.	PCE276.1059
	4.250 in.	2-piece	28 oz. External	No	2.100 in.	STD	2.749 in.	6.200 in.	PCE276.1053
	3.850 in.	2-piece	Internal	No	2.500 in.	STD	3.000 in.	6.605 in.	PCE276.1064
Ford 429 460	4.140 in.	2-piece	Internal	No	2.200 in.	STD	3.000 in.	6.700 in.	PCE276.1127
	4.300 in.	2-piece	Internal	No	2.200 in.	STD	3.000 in.	6.700 in.	PCE276.1065
	4.500 in.	2-piece	Internal	No	2.200 in.	STD	3.000 in.	6.700 in.	PCE276.1066
	3.750 in.								PCE276.1054
Mopar Chrysler BB 383 440	4.125 in.			No	2.375 in.	STD	2.750 in.	6.768 in.	PCE276.1055
	4.150 in.	2-piece	Internal	No				6.768 in.	PCE276.1056
	4.250 in.								PCE276.1057
									PCE276.1057

Billet

Application	Engine Stroke (in)	Rear Main Seal Style	Engine Balance	Lightened	Rod Journal Diameter (in)	Main Journal Diameter (in)	Minimum Rod Length (in)	SKU
Hemi 440	3.750 in.	2-piece	Internal	No	2.375 in.	2.750 in.	n/a	PCE276.1005
Hemi 440	4.100 in.	2-piece	Internal	No	2.375 in.	2.750 in.	n/a	PCE276.1006
Hemi 440	4.250 in.	2-piece	Internal	No	2.200 in.	2.750 in.	n/a	PCE276.1007
Hemi 440	4.500 in.	2-piece	Internal	No	2.200 in.	2.750 in.	n/a	PCE276.1008

Connecting Rods

Time to do some Push-Ups

The connecting rod or conrod connects the piston to the crank or crankshaft. Together with the crank, they form a simple mechanism that converts reciprocating motion into rotating motion. When the cylinder fires, the piston pushes down on the connecting rod, which in turn, causes the crankshaft to rotate. All connecting rods for automotive use need to be lightweight but strong enough to withstand and transmit the thrust from the pistons to an engine's crankshaft. Speedmaster™ has a wide range of connecting rods ready to fulfill all your engine needs.





Improves fatigue strength



Ensures surface integrity



Ensures material quality



Avoid long term distortions



For long lasting and less fatigue



Press-Fit



Full-Floating



51-I
Tensile strength 115,000 Psi

Speedmaster™ "I" Beam connecting rods are manufactured from high quality 5140 steel. Perfect for Small Block engines producing up to 500hp, and Big Block engines producing up to 600hp. Featured in press-fit or full-floating.



43-H
Tensile strength 145,000 Psi

Speedmaster™ "H" Beam connecting rods are manufactured from aircraft quality 4340 chromoly steel that is far superior to the low-carbon 51-series steel. Perfect for SB engines producing up to 700hp, and BB engines up to 850hp.

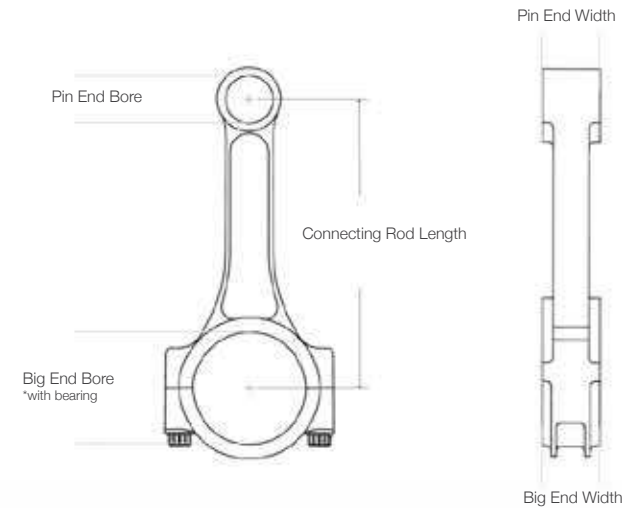
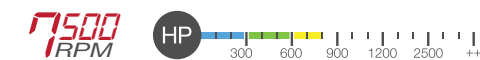

Connecting Rod Length

When measuring connecting rod length, we're really talking about center-to-center length—the distance from the center of the piston pin-end-bore to the center of the big-end bore. Here's an easy method of measuring length:

- Using a properly calibrated caliper, carefully measure from the floor of the pin-end-bore to the roof of the big-end-bore (the shortest distance from bore to bore).
- Using an inside micrometer, measure the diameter of the pin-end bore.
- Using an inside mic, measure the diameter of the big-end-bore (with cap installed and fully torqued to spec). Take this measurement from the 12 o'clock point (center of the rod saddle radius) to the 6 o'clock point (center of the cap radius).
- Add to your first measurement one-half of the pin-end-bore diameter and one-half of the big-end-bore diameter. This is the center-to-center dimension.

Horsepower vs. RPM

When it comes to rod selection, which is more important: horsepower or rpm? Higher power levels increase the compressive force on the connecting rods while higher rpms increase the tensile strain on the rods. As it turns out, most rods don't bend and fail on the compression stroke but are pulled apart at high rpm and break on the exhaust stroke. Consequently, rods need additional compression strength and stiffness to handle higher horsepower loads. But in high-revving engines, increased tensile strength is an absolute must for the rods to survive at high rpm.



43-I
Tensile strength 145,000 Psi

Speedmaster™ "I" Beam connecting rods are manufactured from the same 43-H aircraft quality 4340 chromoly steel but designed to be the most reliable in the racing industry. For an H-Beam to catch up to the compression strength of an otherwise comparable I-Beam, the H-Beam would need to be FAR heavier than the lighter, stronger and more efficient I-Beam design. Perfect for engines producing 1000+ HP.

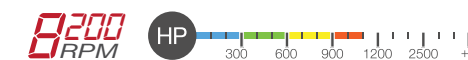

Billet-I
Tensile strength 162,000 Psi

Speedmaster™ forged billet connecting rods start with certified high-nickel 4340 aircraft-quality steel and are fully CNC-machined on the newest generation of equipment to ensure the removal of all surface imperfections. They are specially heat-treated using a multi-phase process to produce the ultimate in strength and reliability.

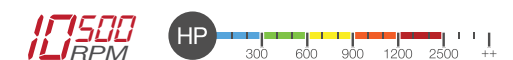

Connecting Rods

51-I

Connecting Rod Length (in)	Wrist Pin Style	Cap Retention Style	Connecting Rod Bolt Diameter	Rod Journal Diameter (in)	Pin End Bore Diameter (in)	Big End Width (in)	Light Weight	Application	SKU
5.090 in.	Press-fit	Through-bolt	3/8 in.	2.123 in.	0.912 in.	0.830 in.	N	Ford 289 302 Windsor	PCE274.1009
	Floating								PCE274.1010
5.315 in.	Floating	Through-bolt	3/8 in.	2.123 in.	0.912 in.	0.830 in.	N	Ford 289 302 Windsor	PCE274.1011
5.400 in.	Floating	Through-bolt	3/8 in.	2.123 in.	0.912 in.	0.830 in.	N	Ford 289 302 Windsor	PCE274.1012
					0.927 in.				PCE274.1013
5.700 in.	Press-fit	Through-bolt	3/8 in.	2.100 in.	0.927 in.	0.945 in.	N	Chevrolet SBC 350	PCE274.1001
	Press-fit	Bolt & Nut							PCE274.1002
	Floating	Through-bolt							PCE274.1003
5.956 in.	Floating	Through-bolt	3/8 in.	2.310 in.	0.912 in.	0.830 in.	N	Ford 351 Windsor	PCE274.1015
	Press-fit				0.927 in.				PCE274.1014
6.000 in.	Press-fit	Through-bolt	3/8 in.	2.100 in.	0.927 in.	0.945 in.	N	Chevrolet SBC 350	PCE274.1004
	Floating								PCE274.1005
6.125 in.	Floating	Through-bolt	3/8 in.	2.100 in.	0.927 in.	0.945 in.	N	Chevrolet SBC 350	PCE274.1006
6.135 in.	Floating	Through-bolt	3/8 in.	2.200 in.	0.990 in.	0.990 in.	N	Chevrolet BBC 454	PCE274.1017
	Press-fit								PCE274.1016
6.150 in.	Floating	Through-bolt	3/8 in.	2.100 in.	0.927 in.	0.945 in.	N	Chevrolet SBC 350	PCE274.1114
6.200 in.	Floating	Through-bolt	3/8 in.	2.100 in.	0.927 in.	0.945 in.	N	Chevrolet SBC 350	PCE274.1007
6.250 in.	Floating	Through-bolt	3/8 in.	2.100 in.	0.927 in.	0.945 in.	N	Chevrolet SBC 350	PCE274.1008
6.385 in.	Floating	Through-bolt	3/8 in.	2.200 in.	0.990 in.	0.990 in.	N	Chevrolet BBC 454	PCE274.1018
6.535 in.	Floating	Through-bolt	3/8 in.	2.200 in.	0.990 in.	0.990 in.	N	Chevrolet BBC 454	PCE274.1019
6.605 in.	Press Fit	Through-bolt	3/8 in.	2.499 in.	1.040 in.	0.994 in.	N	Ford BBF 460	PCE274.1119
6.800 in.	Floating	Through-bolt	3/8 in.	2.200 in.	0.990 in.	0.990 in.	N	Chevrolet BBC 454	PCE274.1020

43-H

Connecting Rod Length (in)	Wrist Pin Style	Cap Retention Style	Connecting Rod Bolt Diameter	Rod Journal Diameter (in)	Pin End Bore Diameter (in)	Big End Width (in)	Light Weight	Application	SKU			
5.090 in.	Floating	Through-bolt	7/16 in.	2.100 in.	0.912 in.	0.830 in.	N	Ford 289 302 Windsor	PCE274.1037			
5.290 in.	Floating	Through-bolt	7/16 in.	1.771 in.	0.827 in.	0.935 in.	N	Honda B16A	PCE274.1094			
5.315 in.	Floating	Through-bolt	7/16 in.	2.123 in.	0.912 in.	0.830 in.	N	Ford 289 302 Windsor	PCE274.1038			
5.370 in.	Floating	Through-bolt	7/16 in.	2.123 in.	0.927 in.	0.830 in.	N	Ford 289 302 Windsor Ford 289 302 Windsor	PCE274.1044			
				2.100 in.					PCE274.1041			
5.394 in.	Floating	Through-bolt	7/16 in.	1.771 in.	0.827 in.	0.935 in.	N	Honda B18B	PCE274.1096			
				1.771 in.				0.748 in.	0.898 in.	Honda D16A	PCE274.1095	
5.400 in.	Floating	Through-bolt	7/16 in.	2.100 in.	0.912 in.	0.830 in.	N	Ford 289 302 Windsor	PCE274.1039			
				2.123 in.					PCE274.1042			
				2.123 in.					0.927 in.	PCE274.1043		
				2.100 in.					0.927 in.	PCE274.1040		
5.430 in.	Floating	Through-bolt	7/16 in.	1.771 in.	0.827 in.	0.858 in.	Y	Honda B18C	PCE274.1097			
5.580 in.	Floating	Through-bolt	7/16 in.	1.890 in.	0.866 in.	0.935 in.	N	Honda H22	PCE274.1098			
5.625 in.	Floating	Through-bolt	7/16 in.	2.125 in.	0.927 in.	0.880 in.	N	Holden 253 304 308	PCE274.1115			
5.630 in.	Floating	Through-bolt	7/16 in.	1.890 in.	0.866 in.	0.935 in.	N	Honda H23	PCE274.1099			
				2.000 in.				N	PCE274.1021			
				2.100 in.				0.927 in.	0.945 in.	Y	Chevrolet SBC 350	PCE274.1025
				2.100 in.				N	PCE274.1023			
5.700 in.	Floating	Through-bolt	7/16 in.	2.000 in.	0.927 in.	1.050 in.	N	Chevrolet 194 230 292	PCE274.1022			
				2.100 in.				0.880 in.	N	Holden 253 304 308	PCE274.1125	
5.850 in.	Floating	Through-bolt	7/16 in.	2.000 in.	0.866 in.	0.938 in.	N	Ford 4.6L	PCE274.1060			
					0.927 in.				PCE274.1061			
5.900 in.	Floating	Through-bolt	7/16 in.	1.771 in.	0.927 in.	0.880 in.	N	Holden 253 304 308	7			
				2.100 in.					PCE274.1104			
5.933 in.	Floating	Through-bolt	7/16 in.	2.087 in.	0.866 in.	0.938 in.	N	Ford 4.6L	PCE274.1062			
5.956 in.	Floating	Through-bolt	7/16 in.	2.310 in.	0.912 in.	0.830 in.	N	Ford 351 Windsor	PCE274.1046			
					0.927 in.				PCE274.1045			
6.000 in.	Floating	Through-bolt	7/16 in.	2.000 in.	0.927 in.	0.945 in.	Y	Chevrolet SBC 350	PCE274.1026			
				2.100 in.					PCE274.1029			
				2.100 in.					N	PCE274.1028		
				2.000 in.					0.927 in.	1.050 in.	N	Chevrolet 194 230 292
6.100 in.	Floating	Through-bolt	7/16 in.	2.100 in.	0.927 in.	0.945 in.	N	Chevrolet SBC 350	PCE274.1030			
								GM LS	PCE274.1031			
6.123 in.	Floating	Through-bolt	7/16 in.	2.125 in.	0.984 in.	0.927 in.	N	Chrysler 318 340 360	PCE274.1047			
6.125 in.	Floating	Through-bolt	7/16 in.	2.100 in.	0.927 in.	0.945 in.	N	Chevrolet SBC 350	PCE274.1032			
								GM LS	PCE274.1033			
6.135 in.	Floating	Through-bolt	7/16 in.	2.200 in.	0.990 in.	0.990 in.	N	Chevrolet BBC 454	PCE274.1048			
6.200 in.	Floating	Through-bolt	7/16 in.	2.100 in.	0.927 in.	0.945 in.	N	Chevrolet SBC 350	PCE274.1034			
6.250 in.	Floating	Through-bolt	7/16 in.	2.100 in.	0.927 in.	0.945 in.	N	Chevrolet SBC 350	PCE274.1036			

Continued 

Connecting Rods

Continued 43-H

Connecting Rod Length (in)	Wrist Pin Style	Cap Retention Style	Connecting Rod Bolt Diameter	Rod Journal Diameter (in)	Pin End Bore Diameter (in)	Big End Width (in)	Light Weight	Application	SKU
6.300 in.	Floating	Through-bolt	7/16 in.	2.250 in.	0.927 in.	0.945 in.	N	Chevrolet SBC 350	PCE274.1103
6.385 in.	Floating	Through-bolt	7/16 in.	2.200 in.	0.990 in.	0.990 in.	N	Chevrolet BBC 454	PCE274.1049
6.435 in.	Floating	Through-bolt	7/16 in.	2.200 in.	0.990 in.	0.990 in.	N	Chevrolet BBC 454	PCE274.1121
6.490 in.	Floating	Through-bolt	7/16 in.	2.438 in.	0.975 in.	0.871 in.	N	Ford Fe 390 427 428	PCE274.1054
6.535 in.	Floating	Through-bolt	7/16 in.	2.200 in.	0.990 in.	0.990 in.	N	Chevrolet BBC 454	PCE274.1050
6.605 in.	Floating	Through-bolt	7/16 in.	2.499 in.	1.040 in.	1.000 in.	N	Ford BBF 460	PCE274.1055
6.625 in.	Floating	Through-bolt	7/16 in.	2.250 in.	0.980 in.	0.993 in.	N	Pontiac 326 400 455	PCE274.1056
6.658 in.	Floating	Through-bolt	7/16 in.	2.087 in.	0.866 in.	0.938 in.	N	Ford 4.6L	PCE274.1063
6.660 in.	Floating	Through-bolt	7/16 in.	2.200 in.	0.990 in.	0.990 in.	N	Chevrolet BBC 454	PCE274.1118
6.700 in.	Floating	Through-bolt	7/16 in.	2.200 in.	0.990 in.	0.990 in.	N	Chevrolet BBC 454	PCE274.1052
6.735 in.	Floating	Through-bolt	7/16 in.	2.499 in.	0.980 in.	n/a	N	Oldsmobile 400 425 455	PCE274.1059
6.760 in.	Floating	Through-bolt	7/16 in.	2.375 in.	0.990 in.	1.015 in.	N	Mopar 440	PCE274.1058
6.800 in.	Floating	Through-bolt	7/16 in.	2.200 in.	0.990 in.	0.990 in.	N	Chevrolet BBC 454	PCE274.1053
7.100 in.	Floating	Through-bolt	7/16 in.	2.200 in.	0.990 in.	0.990 in.	N	Chevrolet BBC 454	PCE274.1117

43-I

Connecting Rod Length (in)	Wrist Pin Style	Cap Retention Style	Connecting Rod Bolt Diameter	Rod Journal Diameter (in)	Pin End Bore Diameter (in)	Big End Width (in)	Light Weight	Application	SKU
5.090 in.	Floating	Through-bolt	7/16 in.	2.123 in.	0.912 in.	0.830 in.	N	Ford 289 302 Windsor	PCE274.1076
							Y		PCE274.1077
5.256 in.	Floating	Through-bolt	7/16 in.	1.771 in.	0.748 in.	0.848 in.	N	Mitsubishi 4G93	PCE274.1105
							Y		PCE274.1106
5.290 in.	Floating	Through-bolt	7/16 in.	1.771 in.	0.827 in.	0.935 in.	Y	Honda B16A	PCE274.1107
5.315 in.	Floating	Through-bolt	7/16 in.	2.123 in.	0.912 in.	0.830 in.	N	Ford 289 302 Windsor	PCE274.1078
							Y		PCE274.1079
5.394 in.	Floating	Through-bolt	7/16 in.	1.771 in.	0.827 in.	0.935 in.	Y	Honda B18B	PCE274.1108
				2.100 in.	0.927 in.		N		PCE274.1080
				2.123 in.	0.912 in.		N		PCE274.1081
5.400 in.	Floating	Through-bolt	7/16 in.	2.123 in.	0.912 in.	0.830 in.	Y	Ford 289 302 Windsor	PCE274.1082
				2.123 in.	0.927 in.		N		PCE274.1083
5.430 in.	Floating	Through-bolt	7/16 in.	1.771 in.	0.827 in.	0.858 in.	Y	Honda B18C	PCE274.1109
5.580 in.	Floating	Through-bolt	7/16 in.	1.890 in.	0.866 in.	0.935 in.	Y	Honda H22	PCE274.1110
5.630 in.	Floating	Through-bolt	7/16 in.	1.890 in.	0.866 in.	0.935 in.	N	Honda H23	PCE274.1111
				2.000 in.			N		PCE274.1064
5.700 in.	Floating	Through-bolt	7/16 in.	2.100 in.	0.927 in.	0.945 in.	N	Chevrolet SBC 350	PCE274.1065
				2.100 in.			Y		PCE274.1066
5.906 in.	Floating	Through-bolt	7/16 in.	1.771 in.	0.866 in.	1.035 in.	N	Mitsubishi 4G93	PCE274.1112
5.933 in.	Floating	Through-bolt	7/16 in.	2.087 in.	0.866 in.	0.938 in.	N	Ford 4.6L	PCE274.1092
				1.890 in.	0.866 in.	0.935 in.		Honda H22 H23	PCE274.1113
5.950 in.	Floating	Through-bolt	7/16 in.	2.000 in.	0.927 in.	0.945 in.	N	Chevrolet SBC 350	PCE274.1068
5.956 in.	Floating	Through-bolt	7/16 in.	2.310 in.	0.912 in.	0.830 in.	N	Ford 351 Windsor	PCE274.1084

Continued 43-I

Connecting Rod Length (in)	Wrist Pin Style	Cap Retention Style	Connecting Rod Bolt Diameter	Rod Journal Diameter (in)	Pin End Bore Diameter (in)	Big End Width (in)	Light Weight	Application	SKU
	Floating	Through-bolt	7/16 in.	2.250 in.	0.975 in.	0.933 in.	N	OLDSMOBILE	PCE274.1100
				2.000 in.			N		PCE274.1067
6.000 in.	Floating	Through-bolt	7/16 in.	2.100 in.	0.927 in.	0.945 in.	N	Chevrolet SBC 350	PCE274.1069
				2.100 in.			Y		PCE274.1070
6.100 in.	Floating	Through-bolt	7/16 in.	2.100 in.	0.927 in.	0.945 in.	N	GM LS	PCE274.1071
							N		PCE274.1072
6.125 in.	Floating	Through-bolt	7/16 in.	2.100 in.	0.927 in.	0.945 in.	Y	Chevrolet SBC 350	PCE274.1073
6.135 in.	Floating	Through-bolt	7/16 in.	2.200 in.	0.990 in.	0.990 in.	N	Chevrolet BBC 454	PCE274.1085
6.200 in.	Floating	Through-bolt	7/16 in.	2.100 in.	0.927 in.	0.945 in.	N	Chevrolet SBC 350	PCE274.1074
6.250 in.	Floating	Through-bolt	7/16 in.	2.100 in.	0.927 in.	0.945 in.	N	Chevrolet SBC 350	PCE274.1075
6.385 in.	Floating	Through-bolt	7/16 in.	2.200 in.	0.990 in.	0.900 in.	N	Chevrolet BBC 454	PCE274.1086
6.535 in.	Floating	Through-bolt	7/16 in.	2.200 in.	0.990 in.	0.900 in.	N	Chevrolet BBC 454	PCE274.1087
6.605 in.	Floating	Through-bolt	7/16 in.	2.200 in.	1.040 in.	1.000 in.	N	Ford BBF 460	PCE274.1090
6.700 in.	Floating	Through-bolt	7/16 in.	2.200 in.	0.990 in.	0.900 in.	N	Chevrolet BBC 454	PCE274.1088
6.760 in.	Floating	Through-bolt	7/16 in.	2.375 in.	0.990 in.	1.015 in.	N	Mopar 440	PCE274.1091
6.800 in.	Floating	Through-bolt	7/16 in.	2.200 in.	0.990 in.	0.900 in.	N	Chevrolet BBC 454	PCE274.1089

Billet-I

Connecting Rod Length (in)	Wrist Pin Style	Cap Retention Style	Connecting Rod Bolt Diameter	Rod Journal Diameter (in)	Pin End Bore Diameter (in)	Big End Width (in)	Light Weight	Application	SKU
6.000 in.	Floating	Through-bolt	7/16 in.	2.100 in.	0.927 in.	0.945 in.	Y	Chevrolet SBC 350	PCE274.1093

Connecting Rod Bolts

Speedmaster™ connecting rod bolts are precision CNC-machined to exacting specifications and designed for optimum reliability. They are heat-treated and threads are rolled to provide up to ten times more fatigue strength. This makes them far superior to standard OEM fasteners in terms of durability, and fully capable of handling the extra stress of high-combustion engines. Featuring 200,000 psi Yield Strength.



Series	Thread Size	SKU
1900-2000	7/16 in.	PCE275.1002
8640-8740	7/16 in.	PCE275.1003

Pistons

Time to Pump Out Horsepower

Gasoline and air mix together in the combustion chamber above a piston. When an electrical spark ignites that mix, it creates a tiny explosion that drives the piston up and down. That movement turns a crankshaft, which is ultimately responsible for driving a transmission and the wheels. As you might expect, pistons are subjected to more heat, pressure and movement than nearly any other engine part. They have to be built for durability. We've got the right pistons for your application. Speedmaster™ offers both Hypereutectic pistons and forged pistons for high performance engines. Each one has distinct advantages in different applications.



Speedmaster™ Forged Pistons Won 2012 Sema Show Global Media Award.

The Speedmaster™ development team have been pushing the boundaries for years with a main objective "to improve the end user experience"; one of the many industry acknowledgments are the 5 in a row SEMA Show Global Media Awards for their research and development of their Pistons, Turnkey EFI system and Manifolds.



CT-Coat (Ceramic Thermal Coating) is a thin film ceramic thermal barrier that insulate the piston against damaging heat transfer, keeping more of the heat generated by combustion, pushing down on the piston for greater power. By retaining minimal heat on the surface of the piston, less heat is transferred to the incoming fuel mixture, leading to a reduction in pre-ignition which leads to detonation. CT-Coat is available in some Speedmaster™ Hypereutectic pistons, look for the icon.

Hypereutectic

Hypereutectic pistons have a high silicon content alloy which contributes to excellent tensile and fatigue strength, improved thermal characteristics, greater hardness, and increased resistance to scuffing. These pistons offer a more quiet operation and cost less than forged pistons, plus they are an excellent choice for street performance, bracket racing and oval track.

They are strong, light-weight, thermally efficient, they can run tight piston-to-wall clearances (which improves ring seal and longevity), and they have exceptional wear resistance. These pistons are meant to provide performance at a reasonable price.

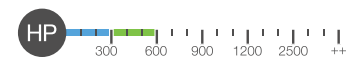

Forged

Made from 4032 aluminum for quieter operation and reduced piston to wall clearance. Up to 20% lighter than traditional forged pistons that eliminate harmful stress concentrations for superior strength. Specifically designed for naturally aspirated or moderate nitrous applications. Forged pistons have advantages when it comes to density, strength, and durability over other piston materials. The forging process eliminates porosity in the metal, improves ductility, and will allow the piston to run cooler than a comparable cast piston.

Forged pistons are right for street performance, endurance racing, drag racing, or all out street performance applications. If you plan to run a very high compression ratio (11:1 and over), high boost supercharger, nitrous oxide, or an engine that will be operating under extreme conditions approaching detonation, you will definitely benefit from a forged piston.

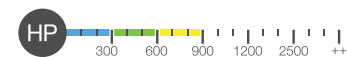



Hypereutectic

Compression Distance (in)	Piston Style	Piston Coating	Piston Head Volume (cc)	Wrist Pin Style	Pin Diameter (in)	Piston Ring Thickness	Bore (in)	SKU
1.100 in.	Flat top, with two valve reliefs	CT-Coat	-4.00cc	Full Floating	0.927 in.	1/16 in. x 1/16 in. x 3/16 in. or 1.5mm x 1.5mm x 3mm	4.000 in.	PCE305.1005
							4.020 in.	PCE305.1006
							4.030 in.	PCE305.1007
							4.040 in.	PCE305.1008
							4.060 in.	PCE305.1009
1.425 in.	Flat top, with two valve reliefs	None	-4.00cc	Full Floating	0.927 in.	1/16 in. x 1/16 in. x 3/16 in. or 1.5mm x 1.5mm x 3mm	4.000 in.	PCE305.1053
							4.020 in.	PCE305.1054
							4.030 in.	PCE305.1055
							4.040 in.	PCE305.1056
							4.060 in.	PCE305.1057
1.125 in.	Flat top, with two valve reliefs	CT-Coat	-4.00cc	Full Floating	0.927 in.	1/16 in. x 1/16 in. x 3/16 in. or 1.5mm x 1.5mm x 3mm	4.020 in.	PCE305.1001
							4.030 in.	PCE305.1002
							4.040 in.	PCE305.1003
							4.060 in.	PCE305.1004
							4.020 in.	PCE305.1073
1.430 in.	Flat top, with two valve reliefs	CT-Coat	-4.00cc	Full Floating	0.927 in.	1/16 in. x 1/16 in. x 3/16 in. or 1.5mm x 1.5mm x 3mm	4.030 in.	PCE305.1074
							4.040 in.	PCE305.1075
							4.060 in.	PCE305.1076
							4.020 in.	PCE305.1040
							4.030 in.	PCE305.1041
1.125 in.	Flat top, with four valve reliefs	Silicone Skirt	-4.00cc	Full Floating	0.927 in.	1/16 in. x 1/16 in. x 3/16 in. or 1.5mm x 1.5mm x 3mm	4.040 in.	PCE305.1042
							4.060 in.	PCE305.1043
							4.000 in.	PCE305.1025
							4.020 in.	PCE305.1026
							4.030 in.	PCE305.1027
1.430 in.	Flat top, with no valve reliefs	None	0.00cc	Full Floating	0.927 in.	1/16 in. x 1/16 in. x 3/16 in. or 1.5mm x 1.5mm x 3mm	4.040 in.	PCE305.1028
							4.060 in.	PCE305.1029
							4.000 in.	PCE305.1035
							4.020 in.	PCE305.1036
							4.030 in.	PCE305.1037
1.430 in.	Flat top, with single valve relief	None	-3.00cc	Full Floating	0.912 in.	1/16 in. x 1/16 in. x 3/16 in. or 1.5mm x 1.5mm x 3mm	4.040 in.	PCE305.1038
							4.060 in.	PCE305.1039



Pistons

Forged

Compression Distance (in)	Piston Style	Piston Coating	Piston Head Volume (cc)	Wrist Pin Style	Pin Diameter (in)	Piston Ring Thickness	Bore (in)	SKU
1.100 in.	 Flat top, with two valve reliefs	None	-4.00cc	Full Floating	0.927 in.	1/16 in. x 1/16 in. x 3/16 in. or 1.5mm x 1.5mm x 3mm	4.000 in.	PCE305.1015
							4.020 in.	PCE305.1016
							4.030 in.	PCE305.1017
							4.040 in.	PCE305.1018
							4.060 in.	PCE305.1019
1.425 in.	 Flat top, with two valve reliefs	None	-4.00cc	Full Floating	0.927 in.	1/16 in. x 1/16 in. x 3/16 in. or 1.5mm x 1.5mm x 3mm	4.000 in.	PCE305.1010
							4.020 in.	PCE305.1011
							4.030 in.	PCE305.1012
							4.040 in.	PCE305.1013
							4.060 in.	PCE305.1014
1.015 in.	 Dish, with two valve reliefs	None	-16.00cc	Press-fit or floating	0.927 in.	1.5mm x 1.5mm x 3mm	4.125 in.	PCE305.1020
							4.145 in.	PCE305.1021
							4.155 in.	PCE305.1022
							4.165 in.	PCE305.1023
							4.185 in.	PCE305.1024



Piston to Bore Clearance

	Application	Ring End Gap Factor	Piston-to-Wall Clearance	
			4.000 - 4.100"	4.100" - and up
Street	Normally Aspirated	.0065 in.	.0015 in. - .0020 in.	.0020 in. - .0025 in.
	Towing	.0080 in.	.0015 in. - .0020 in.	.0020 in. - .0025 in.
	Nitrous / Supercharged	.0080 in.	.0020 in. - .0025 in.	.0025 in. - .0030 in.
Circle Track	2BBL / Restrictor Gas	.0070 in.	.0015 in. - .0045 in.	.0020 in. - .0050 in.
	Unrestricted	.0080 in.	.0025 in. - .0045 in.	.0030 in. - .0050 in.
	Alcohol Injection	.0060 in.	.0025 in. - .0045 in.	.0030 in. - .0050 in.
	Alcohol Carb.	.0080 in.	.0030 in. - .0045 in.	.0030 in. - .0050 in.
Other	Drag Gasoline and Alcohol	.0075 in.	.0015 in. - .0045 in.	.0020 in. - .0050 in.
	Marine	.0080 in.	.0030 in. - .0045 in.	.0035 in. - .0050 in.

Piston Rings

Speedmaster™ piston rings are designed to stand up to the rigor of racing and high-performance street use, while providing a long lasting life. Speedmaster™ piston rings feature: Plasma-moly coated, barrel-shaped, ductile iron top rings that seal against blow-by when the piston rocks in its bore; tapered secondary rings that seal against the oil control ring's upper surface for excellent oil control; and 3-piece oil rings with stainless steel expanders that provide accurate tension without the loss of any horsepower.



STD



Top Ring Thickness	Second Ring Thickness	Oil Ring Thickness	Bore (in)	SKU	Top Ring Thickness	Second Ring Thickness	Oil Ring Thickness	Bore (in)	SKU
			4.000 in.	PCE306.1001				4.000 in.	PCE306.1026
			4.020 in.	PCE306.1002				4.020 in.	PCE306.1027
5/64 in.	5/64 in.	3/16 in.	4.030 in.	PCE306.1003	1/16 in.	1/16 in.	1/8 in.	4.030 in.	PCE306.1028
			4.040 in.	PCE306.1004				4.040 in.	PCE306.1029
			4.060 in.	PCE306.1005				4.060 in.	PCE306.1030
1/16 in.	1/16 in.	3/16 in.	4.000 in.	PCE306.1017				4.000 in.	PCE306.1031
			4.020 in.	PCE306.1018				4.020 in.	PCE306.1032
			4.030 in.	PCE306.1019	1/16 in.	1/16 in.	3/16 in.	4.030 in.	PCE306.1033
			4.040 in.	PCE306.1020				4.040 in.	PCE306.1034
			4.060 in.	PCE306.1021				4.060 in.	PCE306.1035
			4.000 in.	PCE306.1022				4.125 in.	PCE306.1041
			4.020 in.	PCE306.1051				4.145 in.	PCE306.1042
1.5mm	1.5mm	3.0mm	4.030 in.	PCE306.1023	1/16 in.	1/16 in.	3/16 in.	4.155 in.	PCE306.1043
			4.040 in.	PCE306.1024				4.165 in.	PCE306.1044
			4.060 in.	PCE306.1025				4.185 in.	PCE306.1045
								4.000 in.	PCE306.1036
								4.020 in.	PCE306.1037
1.5mm	1.5mm	3.0mm	4.030 in.	PCE306.1038				4.030 in.	PCE306.1038
			4.040 in.	PCE306.1039				4.040 in.	PCE306.1039
			4.060 in.	PCE306.1040				4.060 in.	PCE306.1040
								4.125 in.	PCE306.1046
								4.145 in.	PCE306.1047
1.5mm	1.5mm	3.0mm	4.155 in.	PCE306.1048				4.155 in.	PCE306.1048
			4.165 in.	PCE306.1049				4.165 in.	PCE306.1049
			4.185 in.	PCE306.1050				4.185 in.	PCE306.1050

Engine Rotating Kits

We've done the Hard Work for You

A.K.A Stroker Kits

Churn out all the asphalt-chewing, road-grating horsepower you want with our massive selection of rotating assemblies! Speedmaster™ kits bring together everything you need, including crankshaft, connecting rods, pistons, and other essential bottom-end components. Maximize your budget with a standard, all-in-one rotating assembly or maximize displacement with a cubic inch-enhancing stroker kit. We carry engine rotating kits for a large array of applications.



Application	Actual Engine CID	Bore (in)	Engine Stroke (in)	Piston Material	Crankshaft Material	RMS Style	Connecting Rod Material	Connecting Rod Beam Style	Conrod Length	SKU
Chevrolet SBC 350	383	4.030 in.	3.750 in.	Hypereutectic	Cast	1-piece	5140 Chromoly Steel	I-beam	5.700 in.	PCE290.1009
							6.000 in.	PCE290.1010		
							4340 Chromoly Steel	H-beam	5.700 in.	PCE290.1011
							6.000 in.	PCE290.1012		
							5140 Chromoly Steel	I-beam	5.700 in.	PCE290.1036
							6.000 in.	PCE290.1037		
							4340 Chromoly Steel	H-beam	5.700 in.	PCE290.1038
							6.000 in.	PCE290.1039		
							4340 Chromoly Steel	H-beam	5.700 in.	PCE290.1013
							6.000 in.	PCE290.1014		
Chevrolet BBC 454	496	4.310 in.	4.250 in.	Forged	Forged 4340	2-piece	4340 Chromoly Steel	H-beam	5.700 in.	PCE290.1015
							6.000 in.	PCE290.1016		
							4340 Chromoly Steel	H-beam	6.000 in.	PCE290.1017
							6.000 in.	PCE290.1018		
Ford 302 Windsor	347	4.030 in.	3.400 in.	Hypereutectic	Cast C-RJ Cast W-RJ	1-piece	4340 Chromoly Steel	H-beam	5.400 in.	PCE290.1020
							6.000 in.	PCE290.1021		
							4340 Chromoly Steel	H-beam	5.370 in.	PCE290.1022
Ford 351 Windsor	347	4.030 in.	3.400 in.	Forged	Forged 4340 C-RJ Forged 4340 W-RJ	1-piece	4340 Chromoly Steel	H-beam	5.400 in.	PCE290.1023
							6.000 in.	PCE290.1024		
							4340 Chromoly Steel	H-beam	6.150 in.	PCE290.1042
Ford 351 Cleveland	393	4.030 in.	3.850 in.	Hypereutectic	Cast	1-piece	4340 Chromoly Steel	H-beam	6.200 in.	PCE290.1025
							6.000 in.	PCE290.1026		
							5140 Chromoly Steel	I-beam	6.150 in.	PCE290.1027
							4340 Chromoly Steel	H-beam	6.125 in.	PCE290.1028
							6.000 in.	PCE290.1029		
GM LSX	408	4.030 in.	4.000 in.	Forged	Cast	1-piece	4340 Chromoly Steel	H-beam	6.125 in.	PCE290.1030
							6.000 in.	PCE290.1031		
							4340 Chromoly Steel	H-beam	6.125 in.	PCE290.1040
							5.700 in.	PCE290.1032		
Holden 304 308	355	4.030 in.	3.480 in.	Hypereutectic	Cast C-RJ Cast C-RJ	Rope	4340 Chromoly Steel	H-beam	5.700 in.	PCE290.1033
							6.000 in.	PCE290.1034		
							4340 Chromoly Steel	H-beam	5.900 in.	PCE290.1035

A Stroker kit is an aftermarket assembly that increases the displacement of a reciprocating engine by increasing the travel of the piston (that is, the piston moves further up and/or down in the cylinder). This is done by using a different crankshaft where the crank pin is moved further away from the center of the axis of rotation of the crankshaft.

Two key characteristics differentiate stroker kits

First, and most important, the crankshaft's rod journals are physically farther from the main journals than on the original equipment. A given extension in the distance between the rod and main journals results in twice that distance in increase of piston travel.

The second key characteristic of a stroker kit versus OEM is the required changes to allow a stroked crank to 'fit'. This is accomplished in one of three ways:

- Location of the piston pin (and the top of the rod) within the piston, or the compression height is shortened.
- Length of the rod is shortened.
- Height of the cylinder is lengthened.

Harmonic Balancers

Vibration-less

Each time a cylinder fires, a force acts upon the crankshaft, causing it to twist. But this force also causes vibrations in the crankshaft, and at certain frequencies, the shaft can resonate, which makes the vibrations even worse. These vibrations from the engine can become too much for the crankshaft to bear, causing it to fail. This is where the harmonic balancer comes in. It is bolted at the front end of the crankshaft to help absorb vibrations.



Elastomer

Speedmaster™ Harmonic dampers are manufactured from forged K1045 low carbon steel and tuned elastomer between the two layers of steel. These dampers feature a bonding process which adheres the elastomer to the i.d. of the inertia ring and the o.d. of the hub, utilizing a strong adhesive along with an improved elastomer to create a much stronger bond. They also feature clear, white, easy-to-read timing marks against a painted black background. The steel inertia ring rotates harmonically with the engine and absorbs the torsion vibration from the rotating assembly at any frequency and RPM. All dampers are tested to withstand 15 tons press force without separation and tested to 12,500 RPM for explosion proof racing application..

Fluid

Speedmaster™ fluid Harmonic dampers are manufactured from forged K1045 low carbon steel and filled with high viscosity silicone fluid. A nylon ring and the nylon position guides allow the steel inertia ring to rotate freely inside the housing. The steel inertia ring rotates harmonically with the engine and absorbs the torsion vibration from the rotating assembly at any frequency and RPM. It thus extends the life of crankshaft and bearing and allows the engine to produce more power and torque. All dampers are tested to 12,500 RPM for explosion proof. They also feature clear, easy-to-read timing marks.



Quick Tip

Internal or External?

When identifying your existing damper, (balancer) you must look on the backside. This is not visible if the damper is mounted on the engine. If your damper has no offset in the casting or weight, then you have an internal, (neutral) style damper. If you do see the offset in the casting or a weight, you have what is classified as an external damper.

Before Installing

Inspect crankshaft snout, crankshaft keyway and key for wear or damage and repair prior to fitting your new Speedmaster™ balancer. Do Not force or hit the balancer to install it as accuracy will be lost. Make sure you are using the correct counterweight or neutral style of balancer for your application. Do not drill holes in the outer ring when balancing, use the additional holes supplied in the inner hub for mallory metal or attend to the inner hub or crankshaft or flywheel or flexplate, never the outer ring. It must remain Neutral at all Times.

Elastomer

Application	Outside Diameter (in)	Engine Balance	Safety Rating	Degree Marking Range	Harmonic Balancer Finish	SKU
Chevrolet SBC 350	-	Internal	Not SFI-approved	50 BTDC to 10 ATDC	Black painted	PCE291.1037
	6.750 in.	Internal	Not SFI-approved	60 BTDC to 0 TDC	Black painted	PCE291.1001
	6.750 in.	Internal	Not SFI-approved	50 BTDC to 10 ATDC	Black painted	PCE291.1034
	6.750 in.	Internal	SFI-approved 18.1	60 BTDC to 0 TDC	Black painted	PCE291.1010
	6.750 in.	Internal (Light weight)	Not SFI-approved	60 BTDC to 0 TDC	Black painted	PCE291.1009
	8.000 in.	Internal	Not SFI-approved	60 BTDC to 0 TDC	Black painted	PCE291.1003
	8.000 in.	Internal	Not SFI-approved	50 BTDC to 10 ATDC	Chrome	PCE291.1036
	8.000 in.	Internal	SFI-approved 18.1	60 BTDC to 0 TDC	Black painted	PCE291.1011
	8.000 in.	Internal	Not SFI-approved	50 BTDC to 10 ATDC	Black painted	PCE291.1051
	8.000 in.	Internal	Not SFI-approved	50 BTDC to 10 ATDC	Black painted	PCE291.1035
Chevrolet BBC 454	-	Internal	Not SFI-approved	50 BTDC to 10 ATDC	Black painted	PCE291.1042
	6.750 in.	Internal	Not SFI-approved	60 BTDC to 0 TDC	Black painted	PCE291.1062
	6.750 in.	External	Not SFI-approved	60 BTDC to 0 TDC	Black painted	PCE291.1070
	8.000 in.	External	Not SFI-approved	60 BTDC to 0 TDC	Black painted	PCE291.1006
	8.000 in.	External	SFI-approved 18.1	60 BTDC to 0 TDC	Black painted	PCE291.1014
	8.000 in.	Internal	SFI-approved 18.1	60 BTDC to 0 TDC	Black painted	PCE291.1013
	8.000 in.	Internal	Not SFI-approved	60 BTDC to 0 TDC	Black painted	PCE291.1005
	6.250 in.	Internal	Not SFI-approved	50 BTDC to 10 ATDC	Black painted	PCE291.1038
Chevrolet 400	6.750 in.	External	SFI-approved 18.1	60 BTDC to 0 TDC	Black painted	PCE291.1012
	6.750 in.	External	Not SFI-approved	40 BTDC to 0 TDC	Black painted	PCE291.1002
	8.000 in.	External	Not SFI-approved	60 BTDC to 0 TDC	Black painted	PCE291.1004
	8.000 in.	Internal	Not SFI-approved	50 BTDC to 10 ATDC	Chrome	PCE291.1040
	8.000 in.	Internal	Not SFI-approved	50 BTDC to 10 ATDC	Black painted	PCE291.1039
Chevrolet BBC 396 427	8.000 in.	Internal	Not SFI-approved	50 BTDC to 10 ATDC	Black painted	PCE291.1041
Ford SB 289 302 351 HO Windsor	-	External, 28 oz. imbalance	Not SFI-approved	50 BTDC to 10 ATDC	Black painted	PCE291.1043
	-	External, 50 oz. imbalance				PCE291.1057
Ford SB 289 302 351 SPHO	-	External	Not SFI-approved	50 BTDC to 10 ATDC	Black painted	PCE291.1045
	-	External	Not SFI-approved	50 BTDC to 10 ATDC	Black painted	PCE291.1044
	-	Internal	Not SFI-approved	50 BTDC to 10 ATDC	Black painted	PCE291.1056
Ford SB 289 302 351 Windsor	6.400 in.	External, 28 oz. imbalance	Not SFI-approved	40 BTDC to 0 TDC	Black painted	PCE291.1007
	6.400 in.	External, 28 oz. imbalance	SFI-approved 18.1	40 BTDC to 0 TDC	Black painted	PCE291.1015
	6.481 in.	External, 28 oz. imbalance	Not SFI-approved	40 BTDC to 0 TDC	Black painted	PCE291.1008
	6.481 in.	External, 50 oz. imbalance	SFI-approved 18.1	40 BTDC to 0 TDC	Black painted	PCE291.1016
GM LS1	-	Internal	Not SFI-approved		Black painted	PCE291.1061
Holden 253 304 308	-	Internal	Not SFI-approved	50 BTDC to 10 ATDC	Black painted	PCE291.1060
Mopar Chrysler SB 318 340 360	7.250 in.	Internal	SFI-approved 18.1	50 BTDC to 270 TDC	Black painted	PCE291.1063
Oldsmobile 400 425 455	-	Internal	Not SFI-approved	50 BTDC to 10 ATDC	Black painted	PCE291.1050



Harmonic Balancers

Fluid

Application	Outside Diameter (in)	Engine Balance	Safety Rating	Degree Marking Range	Harmonic Balancer Finish	SKU
Chevrolet SBC 350	6.250 in.	Internal	Not SFI-approved	50 BTDC to 10 ATDC	Black painted	PCE291.1017
					Chrome	PCE291.1018
Chevrolet BB 454	8.000 in.	External	Not SFI-approved	50 BTDC to 10 ATDC	Black painted	PCE291.1023
			SFI-approved 18.1	50 BTDC to 270 TDC		PCE291.1064
Chevrolet BB 396 427	8.000 in.	Internal	Not SFI-approved	50 BTDC to 10 ATDC	Black painted	PCE291.1021
					Chrome	PCE291.1022
Chevrolet 400	7.250 in.	External	Not SFI-approved	50 BTDC to 10 ATDC	Black painted	PCE291.1019
					Chrome	PCE291.1020
Ford 429 460	7.250 in.	Internal	Not SFI-approved	50 BTDC to 10 ATDC	Black painted	PCE291.1028
			SFI-approved 18.1	50 BTDC to 270 TDC	Chrome	PCE291.1029
Ford FE 390 427 428	7.250 in.	Internal	SFI-approved 18.1	50 BTDC to 10 ATDC	Black painted	PCE291.1066
			SFI-approved 18.1	50 BTDC to 10 ATDC	Black painted	PCE291.1074
Ford SB 289 302 351 Ho Windsor	6.625 in.	External, 50 oz. imbalance	Not SFI-approved	50 BTDC to 10 ATDC	Black painted	PCE291.1026
	6.625 in.	External, 50 oz. imbalance	Not SFI-approved	50 BTDC to 10 ATDC	Chrome	PCE291.1027
Ford SB 289 302 351 Windsor	6.625 in.	External, 28 oz. imbalance	Not SFI-approved	50 BTDC to 10 ATDC	Black painted	PCE291.1024
					Chrome	PCE291.1025
GM LSX LS1 LS6	7.250 in.	Internal	SFI-approved 18.1	n/a	Black painted	PCE291.1073
Mini Cooper R52 R53	Stock	Stock Compatible	SFI-approved 18.1	n/a	Black painted	PCE291.1069
Mini Cooper R55 R56 R58 R59 R60	Stock	Stock Compatible	SFI-approved 18.1	n/a	Black painted	PCE291.1068
Mopar Chrysler BB 383 440	7.250 in.	Internal	Not SFI-approved	30 BTDC to 10 ATDC	Chrome	PCE291.1031
Mopar Chrysler BB HEMI 440	7.250 in.	Internal	SFI-approved 18.1	50 BTDC to 270 TDC	Black painted	PCE291.1067
Mopar Chrysler SB 318 340 360	7.250 in.	Internal	Not SFI-approved	50 BTDC to 10 ATDC	Black painted	PCE291.1030
Oldsmobile 400 425 455	6.625 in.	External, 25 oz. imbalance	Not SFI-approved	50 BTDC to 10 ATDC	Black painted	PCE291.1033
		Internal	SFI-approved 18.1	50 BTDC to 270 TDC		PCE291.1065
Oldsmobile 455	6.750 in.	External, 25 oz. imbalance	SFI-approved 18.1	50 BTDC to 10 ATDC	Black painted	PCE291.1075
Pontiac 326 400 455	6.625 in.	Internal	Not SFI-approved	50 BTDC to 10 ATDC	Black painted	PCE291.1032

Harmonic Balancer Bolts

As the crankshaft flexes, the damper absorbs incredible amounts of energy. Speedmaster™ damper bolt kits will ensure that your balancer is locked into position. They feature a 1/4 in. thick wide-area washer and an extra-tall, 12-point head that accepts a deep socket to eliminate the fear of stripping the head.



Application	Thread Size	Underhead Length (in)	Head Style	Washer Included	Fastener Yield Strength (psi)	Fastener Material	Fastener Finish	SKU
Chevrolet SBC 350	5/8-18 in. RH	1.880 in.	12-point	Yes	200,000 psi	Chromoly	Black oxide	PCE292.1001
Chevrolet BBC 454	1/2-20 in. RH	1.550 in.	12-point	Yes	200,000 psi	Chromoly	Black oxide	PCE292.1002
Ford SB BB 302 351 427 460 Windsor Cleveland FE	5/8-18 in. RH	1.880 in.	12-point	Yes	200,000 psi	Chromoly	Black oxide	PCE292.1003
GM LSX LS1 LS2 LS3 LS6	16mm x 2.0	4.330 in.	12-point	Yes	200,000 psi	Chromoly	Black oxide	PCE292.1004

Harmonic Balancer Spacers

These Speedmaster™ spacers have been manufactured for the modern fluid and race steel elastic performance balancers and dampers available on today's market. It allows the proper fitment, and alignment of standard type pulley's to these performance type applications. They are precision-machined on CNC equipment for a perfect fit, have a 4-bolt pulley pattern, and are available in three thicknesses for different engines. Suits 4 Hole ONLY 302-351-383-393-408 Cleveland & 289-302-347-351 Windsor.



Spacer Type	Pulley Bolt Pattern	Pulley Spacer Material	Pulley Spacer Finish	Pulley Spacer Thickness (in)	SKU
Crankshaft	4-bolt	Aluminum	Natural	0.350 in.	PCE244.1001
				0.875 in.	PCE244.1002
				0.950 in.	PCE244.1003

Timing Tape

Accurate ignition timing is one of the most vital adjustments you can make to your engine. Proper timing can mean the difference between winning and losing a race or even blowing an engine (as a worst case scenario). Speedmaster™ Timing Tapes help you to recognize the importance of the timing. They come with eight different tapes to fit common balancers ranging from 5.25 in. to 8 in. in diameter. These tapes are marked off in one degree increments from 14 degrees ATDC to 64 degrees BTDC and are printed on a tough, chemical resistant material. Not only do the Speedmaster™ Timing Tapes help you get an exact timing setting, they allow you to see exactly where the Total timing is set. Remember, the Total timing is just as critical, if not more, than the initial timing and the Speedmaster™ Timing Tape will help you ensure that it is set accurately.

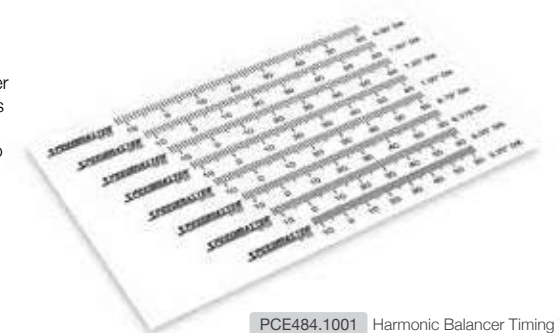

PCE484.1001 Harmonic Balancer Timing Tape

Timing Systems

The Ultimate in Cam Timing

The most important part of the engine is the timing setup that you choose as it keeps the crankshaft and camshaft in sync with each other assuring the best performance from the engine. Speedmaster™ offers a few different variations of timing setups so take the time to read up on the different products as they are one of the most important decisions you will make on an engine.



Chain Drive

Speedmaster™ 9 Keyway Double Row Timing Chain Kits are CNC Machined from billet, Engineered for accurate, consistent timing, faster acceleration and top-speed performance. Trust Speedmaster™ to give you timing sets that will deliver accurate, reliable cam timing. Our billet steel true roller timing sets have rugged double-row, true-roller chains teamed up with billet steel crank and cam sprockets. The crank sprockets have multiple keyways, which allow you to modify your cam timing. Check our new Easy-just line.



Gear Drive

Speedmaster™ gear drives are great for you folks who want better timing. Their dual-idler design has CNC-machined components and they are easy to install. These drives fit under your stock timing cover and come complete with instructions. Minor machining may be required on some applications. Note: Not designed to work on engines with a knock sensor.



Belt Drive

Speedmaster™ belt drives represent the ultimate in cam timing systems, providing competition engine builders with the most accurate valvetrain components available today. These drives are designed to absorb a significant amount of crankshaft harmonics, which will affect valve motion if they reach the valvetrain. These systems require less power to operate than conventional belt drives, and are proven to be more durable than either gear or chain drives.

Easy-just

Speedmaster™ Easy-just Timing Chain Set allows you advance or retard your timing 6° without having to remove your valve covers or having to back off your rocker arms. Exact Radial run out tolerance insures your timing adjustments are accurate. Features a billet cam and crank sprocket. The crank sprocket is also heat treated for additional strength. Heavy-Duty roller chain and one-piece roller thrust bearing assembly insure smooth operation.



PCE264.1017 Chevy SBC 350 Double Roller 2pc Adj. Billet Steel

Assemblies

Speedmaster™ timing-gear drive assemblies are designed for all-out competition, but work equally well in any application. Their proven fixed idler-gear system is capable of maintaining consistent cam timing without siphoning off power, the way 4-gear types can. Made for strength and durability, these gear drives will last indefinitely.



PCE267.1011 Chevy SBC 350 Single Idler Noisy Gear Drive Assemblies

Chain Drive

Application	Timing Chain Style	Maximum Advance/Retard		Thrust Bearing Included	SKU
		@ Camshaft	@ Crankshaft		
Chevy SBC 350	Double roller	4 degree	8 degree	Yes (Torrington Bearing)	PCE264.1001
				Yes	PCE264.1003
Chevy SBC 350 Late	Double roller	4 degree	8 degree	Yes (Torrington Bearing)	PCE264.1002
				Yes	PCE264.1004
Chevy BBC 454	Double roller	4 degree	8 degree	Yes	PCE264.1005
Ford SB 289 302 351 Windsor	Double roller	4 degree	8 degree	Yes (Torrington Bearing)	PCE264.1006
				Yes	PCE264.1007
Ford 5.0L 5.8L Late Windsor	Double roller	4 degree	8 degree	Yes (Torrington Bearing)	PCE264.1008
				Yes	PCE264.1009
Ford 302 351C Cleveland	Double roller	4 degree	8 degree	Yes	PCE264.1010
Ford 302 351C Cleveland SVO	Double roller	4 degree	8 degree	Yes	PCE264.1011
Ford 429 460	Double roller	4 degree	8 degree	Yes	PCE264.1012
				Yes (Torrington Bearing)	PCE264.1015
Holden 253 304 308	Double roller	4 degree	8 degree	No	PCE264.1013
	Double roller - Single Keyway			PCE264.1014	
Oldsmobile 400 425 455	Double roller	4 degree	8 degree	No	PCE264.1016

Gear Drive

Application	Gear Drive Idler Style	Camshaft Gear Attachment	Maximum Advance/Retard at Camshaft	Maximum Advance/Retard at Crankshaft	Thrust Bearing Included	Offset Bushings Included	SKU
Chevrolet SBC 350	Dual idler	3-bolt	5 degree	2 1/2 degree	Yes	Yes	PCE267.1002
Chevrolet BBC 454	Dual idler	3-bolt	5 degree	2 1/2 degree	Yes	Yes	PCE267.1003
GM LS1 LS6	Dual idler	3-bolt	4 degree	2 degree	No	Yes	PCE267.1010
Holden 253 304 308	Dual idler	1-bolt	4 degree	2 degree	No	Yes	PCE267.1007
Ford 302 351C Cleveland	Dual idler	1-bolt	4 degree	2 degree	Yes	Yes	PCE267.1005
Ford 429 460	Dual idler	3-bolt	4 degree	2 degree	No	No	PCE267.1006
Ford SB 289 302 351 Windsor	Dual idler	1-bolt	4 degree	2 degree	No	Yes	PCE267.1004
Mopar Chrysler BB 383 440	Dual idler	3-bolt	4 degree	2 degree	No	Yes	PCE267.1009
Oldsmobile 400 425 455	Dual idler	1-bolt	6 degree	4 degree	No	Yes	PCE267.1008

Belt Drive

Application	Belt Drive System Style	Adjustable Cam Sprocket	Camshaft Location	Belt Included	SKU
Chevrolet SBC 350	Dry	Yes	Standard	Yes	PCE262.1001
Chevrolet BBC 454	Dry	Yes	Standard	Yes	PCE262.1002
Ford SB 289 302 351 Windsor	Dry	Yes	Standard	Yes	PCE262.1003
Ford 302 351C Cleveland	Dry	Yes	Standard	Yes	PCE262.1005
Ford 429 460	Dry	Yes	Standard	Yes	PCE262.1004

Timing Components

Timing Pointers

Speedmaster™ timing tabs are precision-manufactured and bolt on using your existing timing cover bolts. They're made from quality materials, with a pleasing finish that will complement any engine or get up to four degrees of timing adjustment with Speedmaster™ adjustable timing pointers. They're precision-machined from T6-106 billet aluminum, and are designed for a minimum of clearance between the pointer and damper, so parallax errors reading the timing marks are virtually eliminated.



Application	Ref.	Adjustable	Harmonic Balancer Diameter (in)	Pointer Material	Pointer Finish	SKU
Chevrolet SBC 350	a.	Yes	8.000 in.	Billet aluminum	Polished	PCE268.1002
	b.	No	6.750 in., 7.000 in. and 8.000 in	Steel	Chrome	PCE268.1010
Chevrolet BBC 454	c.	Yes	8.000 in.	Billet aluminum	Polished	PCE268.1001
Ford SB 289 302 351 Windsor	d.	No	All - US Driver Side	Steel	Chrome	PCE268.1003
	e.	No	All -US Passenger Side	Steel	Chrome	PCE268.1004
Ford 302 351C Cleveland	f.	No	All	Steel	Zinc plated	PCE268.1005
Mopar Chrysler BB 383 440	g.	No	All	Steel	Chrome	PCE268.1006

Timing Covers

Speedmaster™ timing covers are the perfect way to add strength and durability to the front of your engine, not to mention increased looks. Speedmaster™ aluminum or steel timing covers are the perfect addition to your powerhouse. Some minor machining may be required for use with cam buttons or roller cams.

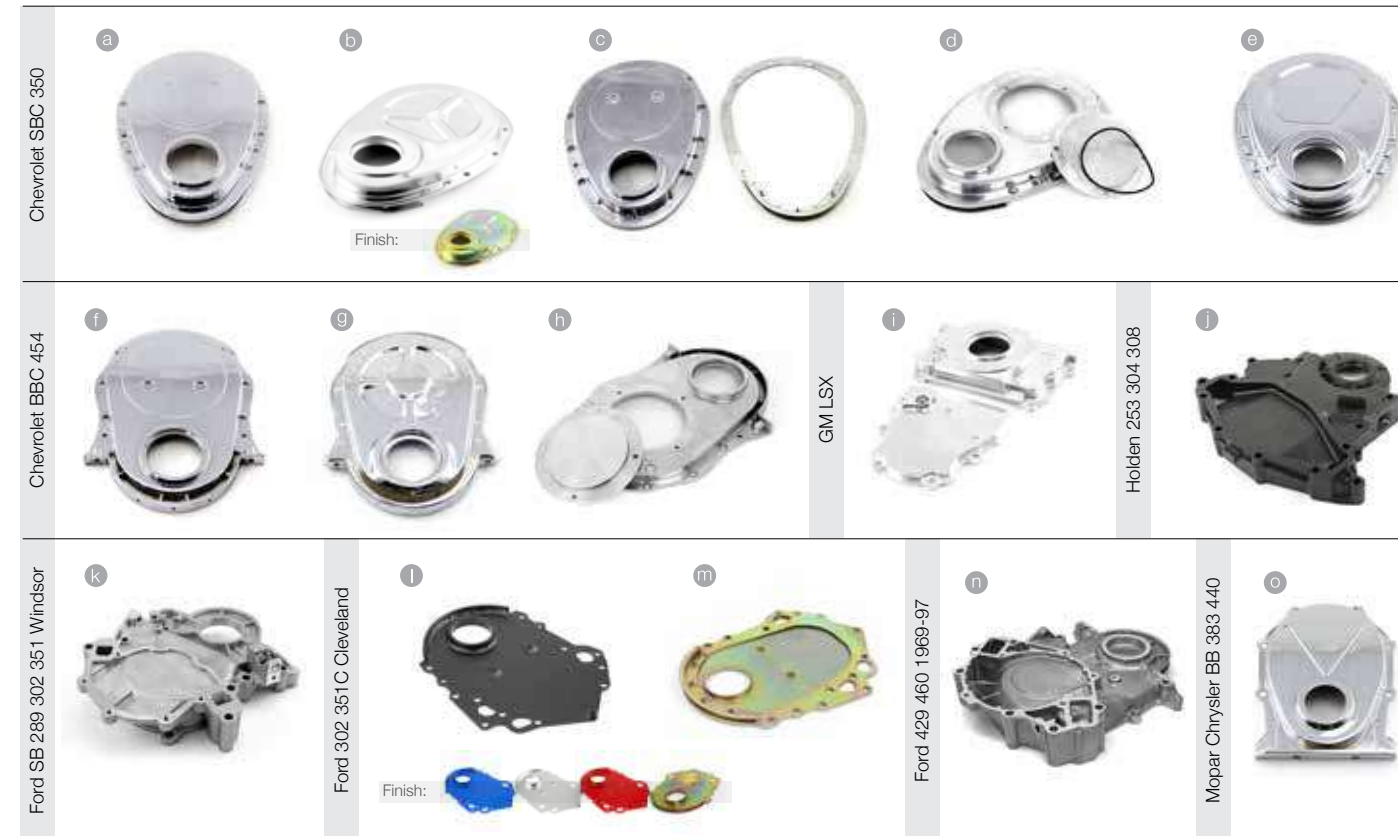

Application	Ref.	Cover Style	Cover Logo	Cover Material	Cover Finish	Notes	SKU
Chevrolet SBC 350	a.	One-piece	Plain	Aluminum	Chrome	-	PCE265.1009
					Polished	With Gasket & Seal	PCE265.1014
	b.	One-piece	Plain	Steel	Chrome	-	PCE265.1008
					Zinc	With Gasket & Seal	PCE265.1013
	c.	2-piece	Procomp	Aluminum	Polished	-	PCE265.1015
						With Gasket & Seal	PCE265.1016
	d.	2-piece	Plain	Aluminum	Polished	Removable Timing Chain Cover	PCE265.1033
						-	PCE265.1005
	e.	2-piece	Plain	Steel	Chrome	With Gasket	PCE265.1004
						-	PCE265.1018
Chevrolet BBC 454	f.	One-piece	Plain	Aluminum	Chrome	Gen 1-4	PCE265.1018
					Polished	Gen 5	PCE265.1017
					Polished	Gen 6	PCE265.1019
	g.	One-piece	Plain	Steel	Chrome	-	PCE265.1002
						Removable Timing Chain Cover	PCE265.1021
	h.	2-piece	Plain	Aluminum	Polished	With Cam Sensor Port	PCE265.1035
Without Cam Sensor Port						PCE265.1036	
Holden 253 304 308 Holden 304 EFI	j.	One-piece	Plain	Aluminum	Black	Non EFI	PCE265.1022
						Fuel Pump Blocked Off	PCE265.1031
Ford SB 289 302 351 Windsor 1968-80 Ford SB 289 302 351 Windsor 5.0L 1981-99	k.	One-piece	Plain	Aluminum	Natural	Non EFI	PCE265.1028
						EFI	PCE265.1029
Ford 302 351C Cleveland	l.	One-piece	Plain	Aluminum	Black anodized	-	PCE265.1032
					Blue anodized	PCE265.1026	
					Silver anodized	PCE265.1027	
					Red anodized	PCE265.1025	
	m.	2-piece	Plain	Steel	Zinc plated	-	PCE265.1023
Ford 429 460 1969-97	n.	One-piece	Plain	Aluminum	Natural	No provision for timing sensor.	PCE265.1030
Mopar Chrysler BB 383 440	o.	One-piece	Plain	Steel	Chrome	-	PCE265.1007

Timing Cover Fasteners

Securing your timing cover is easier than ever with Speedmaster™ timing cover bolt kits.



Application	Head Style	Fastener Style	Washer Included	Fastener Material	Fastener Finish	SKU
Ford SB 289 302 351 Windsor	12 point	Bolt	Yes	Stainless steel	Natural	PCE447.1001

Cylinder Heads

Serious Performance

The cylinder head works by allowing the air-fuel mixture to enter one valve and the exhaust gas to exit the other. Speedmaster™ cylinder heads offer improved power throughout the rpm range for greater throttle response and top-end horsepower.

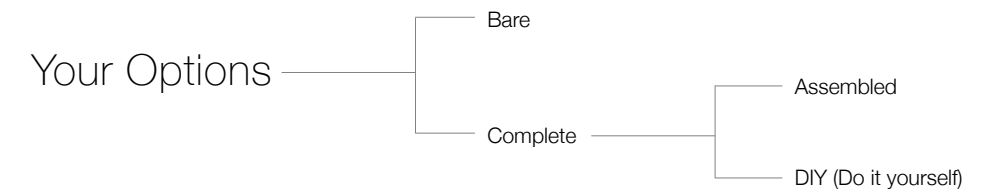

As-Cast

Speedmaster™ cylinder heads feature as-cast ports in both alloy and cast iron and are designed for entry-level street/strip performance applications operating in the idle-to-6500 rpm range. They are available for popular V8 engines. Some of the key features include:

- Bronze valve guides
- CNC finish faces and bolt holes for extreme accuracy
- T6 heat treated gravity die cast construction (alloy heads only)
- OEM accessory bolt patterns for simple compatibility
- Plenty of material for upgrading to larger HP applications
- Machined for screw in studs and guide plates
- Flame hardened valve seats for use with all fuel

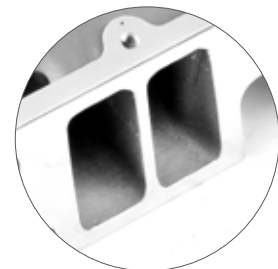

Full-CNC

Speedmaster™ CNC ported cylinder heads are machined on dedicated 4-axis and 5-axis CNC machining centers to ensure accuracy and cost effectiveness.

Combustion Chamber, Exhaust and Intake Ports all fully CNC machined for better flow. CNC combustion chambers offer superior control over flame travel and quench area. CNC Ported heads eliminate human error and variation from port to port. Unsurpassed repeatability from one cylinder head to another that is commonly found in "Hand porting & Polishing".

Combustion chambers are exact in volume - so every cylinder has the same compression ratio. Each port is the same cross section - so every cylinder can reach higher true RPM potential. CNC machining produces ports and chambers to within tolerances of no more than .002"; in turn every cylinder can reach the same power potential and accurate tuning.



Chevrolet Small Block

5.7L 350

All Speedmaster™ 23deg. Small Block Chevy heads are available with Straight or Angled spark plugs. Standard valve sizes are 2.020" Intake, and 1.60" Exhaust, both +.100" length. While the 2.02" valves are standard issue, all of our 23deg. aluminum heads can accept a 2.05" intake valve with minimal additional work. Some of our CNC ported heads (PCE281.1354-1448) are designed around 2.05" Intake valves, and 1.50" exhaust valves. For those racers looking for a head with 800+hp potential, step up to our 15deg heads! These heads have room for huge 2.180"-2.200" intake valves. We even have the matching rockers!

23 Degree



23 Degree - Retro Design



23 Degree - Vortec



15 Degree



Suggested Accessories



Head Gaskets

The head gasket we recommend for our 23deg. heads used on 327/350/383/400 SBC engines without steam holes is Felpro #1003. On engines using the GM 400 block, or aftermarket blocks with steam holes, use Speedmaster™ PCE348.1006 or Felpro #1014.

Intake Gaskets

Our heads are manufactured with both the conventional intake manifold bolt pattern, and the Vortec bolt pattern. If you're installing a Vortec manifold, use Felpro #1255 gaskets. If you are using a conventional intake manifold, use Speedmaster™ PCE349.1002 or Felpro #1266 gaskets.

Push Rods

Our aluminum 23deg. heads typically use +.100" (longer than stock) pushrods, Depending on the components used, it is possible that you may need pushrods shorter or longer than that so we recommend that you use an adjustable pushrod to dial in your rocker geometry and order pushrods to match.

Spark Plugs

All Speedmaster™ 23deg. SBC heads use standard 14mm. x 750" reach, 5/8 hex, gasket seat spark plugs like NGK R5671A-7, Autolite 3924, Champion RC12YC, etc. Remember that higher compression/ boost require a colder heat range spark plug.

Head Bolts / Studs

Our 23 degree heads utilize standard head bolts or studs. Our part number for head bolts is PCE279.1002, and the head studs are PCE279.1001. For the 15 degree heads, we recommend SM2451-15DEG. head stud kit with 3/8" reduced shank on the studs between intake ports. The ARP head bolt part number is 134-3601, and ARP head studs 234-4301 for the 23 degree heads. ARP also makes a head stud kit that is compatible with our 15deg. heads on cast iron blocks with part number 234-4723.

Exhaust Gaskets

We recommend the use of our Exhaust gaskets PCE355.1012 or Felpro #1405 on our 23 degree heads. On our 15 degree heads Felpro #1409.

Flow Results

PCE281.1136			PCE281.1245			PCE281.1487		
These Flow Numbers are un-ported Intake Valve 2.020" Exhaust Valve 1.600"			These Flow Numbers are CNC ported Intake Valve 2.020" Exhaust Valve 1.600"			SBC 15 degree head These Flow Numbers are CNC ported Intake Valve 2.180" w/Sunnen VCS6090 cutter Exhaust Valve 1.600" w/Goodson FT05B cutter		
LIFT	INTAKE	EXHAUST	LIFT	INTAKE	EXHAUST	LIFT	INTAKE	EXHAUST
0.100	58.0	52.0	0.100	67.9	52.1	0.100	73.6	51.8
0.200	113.5	97	0.200	42.2	110.8	0.200	162.8	105.7
0.300	159.2	132.8	0.300	193.6	160.2	0.300	223.5	159.2
0.400	199.7	162.0	0.400	238.9	197.7	0.400	272.5	210.7
0.500	227.6	179.8	0.500	272.7	223.9	0.500	316.6	245.1
0.600	244.2	187.7	0.600	295.1	235.8	0.600	345.4	258.0
0.700	248.3	191.0	0.700	299.1	240.4	0.700	363.3	264.3
						0.800	373.2	268.0
	Intake Port: 190cc Exhaust Port: 72cc Combustion Chamber: 64cc			Intake Port: 217cc Exhaust Port: 78cc Combustion Chamber: 68cc			Intake Port: 283cc Exhaust Port: 92cc Combustion Chamber: 61cc	



Assembled & DIY

Intake Runner Volume (cc)	Combustion Chamber Volume (cc)	Heads Type	Spark Plug Style	Comp. Valve Job	Camshaft Type	Assembled SKU	DIY SKU
190 cc	64 cc	As Cast	Angle	No	Hydraulic Flat Tappet	PCE281.2001	PCE281.1001
					Hydraulic Roller	PCE281.2003	PCE281.1003
					Solid Flat Tappet	PCE281.2002	PCE281.1002
					Hydraulic Flat Tappet	PCE281.2004	PCE281.1004
					Hydraulic Roller	PCE281.2006	PCE281.1006
205 cc	64 cc	As Cast	Straight	No	Solid Flat Tappet	PCE281.2005	PCE281.1005
					Hydraulic Flat Tappet	PCE281.2007	PCE281.1007
					Hydraulic Roller	PCE281.2009	PCE281.1009
					Solid Flat Tappet	PCE281.2008	PCE281.1008
					Hydraulic Flat Tappet	PCE281.2010	PCE281.1010
217 cc	68 cc	Full CNC	Angle	No	Hydraulic Roller	PCE281.2012	PCE281.1012
					Solid Flat Tappet	PCE281.2011	PCE281.1011
					Hydraulic Roller	PCE281.2014	PCE281.1014
					Solid Flat Tappet	PCE281.2013	PCE281.1013
					Solid Roller	PCE281.2015	PCE281.1015
	70 cc	Full CNC	Straight	No	Hydraulic Roller	PCE281.2023	PCE281.1023
					Solid Flat Tappet	PCE281.2022	PCE281.1022
					Solid Roller	PCE281.2024	PCE281.1024
					Hydraulic Roller	PCE281.2017	PCE281.1017
					Solid Flat Tappet	PCE281.2016	PCE281.1016
74 cc	Full CNC	Angle	No	Solid Roller	PCE281.2018	PCE281.1018	
				Hydraulic Roller	PCE281.2026	PCE281.1026	
				Solid Flat Tappet	PCE281.2025	PCE281.1025	
				Solid Roller	PCE281.2027	PCE281.1027	
				Hydraulic Roller	PCE281.2020	PCE281.1020	
74 cc	Full CNC	Straight	No	Solid Flat Tappet	PCE281.2019	PCE281.1019	
				Solid Roller	PCE281.2021	PCE281.1021	
				Hydraulic Roller	PCE281.2029	PCE281.1029	
					Solid Flat Tappet	PCE281.2028	PCE281.1028
					Solid Roller	PCE281.2030	PCE281.1030

Chevrolet Small Block

Bare | As-Cast

Intake Runner Volume (cc)	Combustion Chamber Volume (cc)	Spark Plug Style	Comp. Valve Job	Intake Valve Diameter (in)	Exhaust Valve Diameter (in)	Valve Angle	Cylinder Head Material	SKU
175 cc	59 cc	Straight	No	1.940 in.	1.600 in.	23 deg.	Cast Iron	PCE281.1749
							Aluminum	PCE281.1104
190 cc	64 cc	Angle	No	2.020 in.	1.600 in.	23 deg.	Aluminum	PCE281.1134 **
		Straight	No	2.020 in.	1.600 in.	23 deg.	Aluminum	PCE281.1106
			Aluminum	PCE281.1136				
		Angle	No	1.940 in.	1.600 in.	23 deg.	Aluminum	PCE281.1102
Cast Iron	PCE281.1744							
195 cc	64 cc	Angle	No	2.020 in.	1.600 in.	23 deg.	Aluminum	PCE281.1783
		Straight	No	2.020 in.	1.600 in.	23 deg.	Aluminum	PCE281.1784
205 cc	59 cc	Angle	No	2.020 in.	1.600 in.	23 deg.	Aluminum	PCE281.1160
		Straight	No	2.020 in.	1.600 in.	23 deg.	Aluminum	PCE281.1197
	64 cc	Angle	No	2.020 in.	1.600 in.	23 deg.	Aluminum	PCE281.1159
		Straight	No	2.020 in.	1.600 in.	23 deg.	Aluminum	PCE281.1196
	68 cc	Angle	No	2.020 in.	1.600 in.	23 deg.	Aluminum	PCE281.1174
		Angle	Yes					PCE281.1176
68.5 cc	Angle	No	2.020 in.	1.600 in.	23 deg.	Aluminum	PCE281.1175	
210 cc	64 cc	Straight	No	2.020 in.	1.600 in.	23 deg.	Aluminum	PCE281.1198
		Angle	No	2.020 in.	1.600 in.	23 deg.	Aluminum	PCE281.1170
220 cc	64 cc	Straight	No	2.020 in.	1.600 in.	23 deg.	Aluminum	PCE281.1161 **
230 cc	61 cc	Straight	No	2.020 in.	1.600 in.	15 deg.	Aluminum	PCE281.1486
180 cc	59 cc	Angle	No	2.020 in.	1.600 in.	23 deg.	Cast Iron	PCE281.1755 *
185 cc	64 cc	Angle	No	2.020 in.	1.600 in.	23 deg.	Cast Iron	PCE281.1756 *

* = Vortec
** = Retro Design

Bare | Semi-CNC

CNC Chamber / As-Cast Ports

Intake Runner Volume (cc)	Combustion Chamber Volume (cc)	Spark Plug Style	Comp. Valve Job	Intake Valve Diameter (in)	Exhaust Valve Diameter (in)	Valve Angle	Cylinder Head Material	SKU
190 cc	68 cc	Straight	No	2.020 in.	1.600 in.	23 deg.	Aluminum	PCE281.1137
		Angle	No	2.020 in.	1.600 in.	23 deg.	Aluminum	PCE281.1157
		Straight	No	2.020 in.	1.600 in.	23 deg.	Aluminum	PCE281.1138
190 cc	72 cc	Angle	No	2.020 in.	1.600 in.	23 deg.	Aluminum	PCE281.1155
		Straight	No	2.020 in.	1.600 in.	23 deg.	Aluminum	PCE281.1154
	74 cc	Angle	No	2.020 in.	1.600 in.	23 deg.	Aluminum	PCE281.1153
		Straight	No	2.020 in.	1.600 in.	23 deg.	Aluminum	PCE281.1139
205 cc	68 cc	Straight	Yes	2.020 in.	1.600 in.	23 deg.	Aluminum	PCE281.1201
		Angle	No	2.020 in.	1.600 in.	23 deg.	Aluminum	PCE281.1177
	70 cc	Yes	2.020 in.	1.600 in.	23 deg.	Aluminum	PCE281.1178	
		No	2.020 in.	1.600 in.	23 deg.	Aluminum	PCE281.1202	
	Straight	Yes	2.020 in.	1.600 in.	23 deg.	Aluminum	PCE281.1203	
	74 cc	Angle	No	2.020 in.	1.600 in.	23 deg.	Aluminum	PCE281.1179
		Yes	2.020 in.	1.600 in.	23 deg.	Aluminum	PCE281.1180	
		No	2.020 in.	1.600 in.	23 deg.	Aluminum	PCE281.1204	
		Straight	Yes	2.020 in.	1.600 in.	23 deg.	Aluminum	PCE281.1207

Bare | Full-CNC

Intake Runner Volume (cc)	Combustion Chamber Volume (cc)	Spark Plug Style	Comp. Valve Job	Intake Valve Diameter (in)	Exhaust Valve Diameter (in)	Valve Angle	Cylinder Head Material	SKU
215 cc	64 cc	Angle	No	2.050 in.	1.600 in.	23 deg.	Aluminum	PCE281.1354
		Yes	2.050 in.	1.600 in.	23 deg.	Aluminum	PCE281.1357	
		Straight	No	2.050 in.	1.600 in.	23 deg.	Aluminum	PCE281.1404
			Yes	2.050 in.	1.600 in.	23 deg.	Aluminum	PCE281.1407
	68 cc	Angle	No	2.050 in.	1.600 in.	23 deg.	Aluminum	PCE281.1358
		Yes	2.050 in.	1.600 in.	23 deg.	Aluminum	PCE281.1368	
		Straight	No	2.050 in.	1.600 in.	23 deg.	Aluminum	PCE281.1408
			Yes	2.050 in.	1.600 in.	23 deg.	Aluminum	PCE281.1418
	70 cc	Angle	No	2.050 in.	1.600 in.	23 deg.	Aluminum	PCE281.1373
		Yes	2.050 in.	1.600 in.	23 deg.	Aluminum	PCE281.1383	
		Straight	No	2.050 in.	1.600 in.	23 deg.	Aluminum	PCE281.1423
			Yes	2.050 in.	1.600 in.	23 deg.	Aluminum	PCE281.1433
74 cc	Angle	No	2.050 in.	1.600 in.	23 deg.	Aluminum	PCE281.1388	
	Yes	2.050 in.	1.600 in.	23 deg.	Aluminum	PCE281.1398		
	Straight	No	2.050 in.	1.600 in.	23 deg.	Aluminum	PCE281.1438	
		Yes	2.050 in.	1.600 in.	23 deg.	Aluminum	PCE281.1448	
217 cc	68 cc	Angle	No	2.020 in.	1.600 in.	23 deg.	Aluminum	PCE281.1245
		Yes	2.020 in.	1.600 in.	23 deg.	Aluminum	PCE281.1255	
		Straight	No	2.020 in.	1.600 in.	23 deg.	Aluminum	PCE281.1298
			Yes	2.020 in.	1.600 in.	23 deg.	Aluminum	PCE281.1308
	70 cc	Angle	No	2.020 in.	1.600 in.	23 deg.	Aluminum	PCE281.1260
		Yes	2.020 in.	1.600 in.	23 deg.	Aluminum	PCE281.1270	
		Straight	No	2.020 in.	1.600 in.	23 deg.	Aluminum	PCE281.1313
			Yes	2.020 in.	1.600 in.	23 deg.	Aluminum	PCE281.1323
	74 cc	Angle	No	2.020 in.	1.600 in.	23 deg.	Aluminum	PCE281.1275
		Yes	2.020 in.	1.600 in.	23 deg.	Aluminum	PCE281.1285	
285 cc	61 cc	Straight	No	2.020 in.	1.600 in.	23 deg.	Aluminum	PCE281.1328
			Yes	2.020 in.	1.600 in.	23 deg.	Aluminum	PCE281.1339
285 cc	61 cc	Straight	No	2.020 in.	1.600 in.	15 deg.	Aluminum	PCE281.1487

Chevrolet Big Block

6.5L **396** • 7.4L **454**

As with all Speedmaster™ cylinder heads, our Big Block Chevrolet heads are "Gravity Die Cast". This casting process creates a much more uniform and robust cylinder head. With the increasingly large displacements becoming common, the need for more airflow is necessary. If you are looking to build a 400-500+hp engine, give our PCE281.1489 heads a try. They offer a smaller cross-section to increase the incoming air's velocity, resulting in great drivability, power and economy. On engines over 500hp, use the rectangle port PCE281.1488 heads. The mid-size cross section works well on engines under 540cu.in and under 7000RPM. If you are working on a larger, or higher RPM engine, step up to the CNC ported PCE281.1511 heads. The added volume of the PCE281.1511 intake ports (360cc) helps to fill in the gap between As-Cast performance heads and All-Out racing heads. If you're looking for 750+hp the PCE281.1523 with their competition valve job fit the bill perfectly.



Flow Results

PCE281.1523 These Flow Numbers are CNC ported Intake Valve - 2.250" Exhaust Valve - 1.880"			PCE281.1524 These Flow Numbers are CNC ported Intake Valve - 2.300" Exhaust Valve - 1.880"		
LIFT	INTAKE	EXHAUST	LIFT	INTAKE	EXHAUST
0.100	70.2	62.6	0.100	73.7	62.6
0.200	145.7	123.4	0.200	156.0	123.4
0.300	220.4	169.0	0.300	236.9	169.0
0.400	280.3	209.9	0.400	300.0	209.9
0.500	328.6	245.0	0.500	348.3	245.0
0.600	363.4	271.1	0.600	381.5	271.1
0.700	389.4	292.7	0.700	400.8	292.7
0.800	404.3	310.6	0.800	409.6	310.6
0.900	410.1	321.1	0.900	415.6	321.1
0.950	411.7	324.0	0.950	418.7	324.0

Intake Port: 363cc
Exhaust Port: 155cc
Combustion Chamber: 125cc



Bare | As-Cast

Application	Intake Runner Volume (cc)	Combustion Chamber Volume (cc)	Comp. Valve Job	Intake Valve Diameter (in)	Exhaust Valve Diameter (in)	Valve Angle	Cylinder Head Material	SKU
BBC 396	305 cc	119 cc	No	2.250 in.	1.880 in.	24 deg.	Aluminum	PCE281.1489
BBC 454	320 cc	119 cc	No	2.250 in.	1.880 in.	24 deg.	Aluminum	PCE281.1488

Bare | Full-CNC

Application	Intake Runner Volume (cc)	Combustion Chamber Volume (cc)	Comp. Valve Job	Intake Valve Diameter (in)	Exhaust Valve Diameter (in)	Valve Angle	Cylinder Head Material	SKU
BBC 454	360 cc	125 cc	No	2.250 in.	1.880 in.	24 deg.	Aluminum	PCE281.1511
BBC 454	360 cc	125 cc	Yes	2.250 in.	1.880 in.	24 deg.	Aluminum	PCE281.1523
				2.300 in.	1.880 in.	24 deg.	Aluminum	PCE281.1524



Suggested Accessories

Intake Gaskets

The PCE281.1488 heads work well with our PCE349.1007 rectangle port gaskets. The PCE281.1489 heads require our PCE349.1008 oval port gaskets. If you prefer Felpro gaskets, the PCE281.1488 heads take a 1275 or 1275-5 gasket, depending on the thickness you require.

The CNC-ported heads (PCE281.1511 & PCE281.1523) are matched to the Felpro 1275 & 1275-5 gaskets.

Head Gaskets

Due to the wide combustion chamber needed to fit around the large 2.250/ 1.880" valves, we recommend our PCE348.1004 MLS head gaskets. These gaskets are .041" thick, and fit bore sizes as large as 4.540" on all Mark IV and VI blocks, as well as aftermarket blocks. Felpro 1017 gaskets will also work with these head/ block combos. To install our BBC heads on Mark V blocks, you will need to use Victor Reinz # 4918(R) & #4923(L) head gaskets.

Head Bolts / Studs

Due to the raised (+.625") exhaust port location on our heads, +.100" longer bolts / studs are needed next to each port. Use our PCE279.1005 head stud Kit. ARP #135-3703 12pt. Head bolts, and #235-4303 Head studs work too. If you already have a standard BBC head stud kit and are just looking for the 8 +.100" studs, use our PCE279.1006 or ARP # 235-4306. These heads should be torqued to 65ft.lbs. using high pressure moly lube or 70ft.lbs. using 30wt. oil.

Please consult your fastener manufacturer for their specific recommended torque values.

Exhaust Gaskets

Our BBC heads utilize a 1.88" x 1.88" square exhaust port. This exhaust port requires specific gaskets. Our PCE355.1003 gaskets are made of re-usable copper, or if you prefer paper, use our PCE355.1011. Felpro also offers gaskets that work with our heads as # 1410.

Spark Plugs

Our heads require the use of 14mm. x 3/4" reach 5/8" hex gasket seat spark plugs. Some recommended plugs are; NGK BCP6ES or R5671A-7, Champion RC12YC, Autolite AR3923 or AR3924. Remember these are for mild street engines. Higher compression or boost requires colder spark plugs!

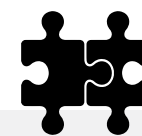

Assembled & DIY



Application	Intake Runner Volume (cc)	Combustion Chamber Volume (cc)	Finish	Comp. Valve Job	Camshaft Type	Assembled SKU	DIY SKU
BBC 396	305 cc	119 cc	As Cast	No	Hydraulic Flat Tappet	PCE281.2034	PCE281.1034
					Hydraulic Roller	PCE281.2036	PCE281.1036
					Solid Flat Tappet	PCE281.2035	PCE281.1035
BBC 454	320 cc	119 cc	As Cast	No	Hydraulic Flat Tappet	PCE281.2031	PCE281.1031
					Hydraulic Roller	PCE281.2033	PCE281.1033
					Solid Flat Tappet	PCE281.2032	PCE281.1032
					Solid Flat Tappet	PCE281.2037	PCE281.1037
					Hydraulic Roller	PCE281.2038	PCE281.1038
					Solid Roller	PCE281.2039	PCE281.1039
BBC 454	360 cc	125 cc	Full CNC	Yes	Solid Flat Tappet	PCE281.2040	PCE281.1040
					Hydraulic Roller	PCE281.2041	PCE281.1041
					Solid Roller	PCE281.2042	PCE281.1042



5.7L LS1/LS6 • 6.0L LS2 • 6.2L LS3/L99 • 7.0L LS7



Our line of LS-series cylinder heads is rapidly expanding. The LS (Gen3/4) platform has many design benefits over the earlier SBC engine designs, most notably the cylinder heads. Although the GM heads are good pieces, we have developed a superior line of heads for modern performance enthusiasts. Like all Speedmaster™ cylinder heads, the LS-series heads are produced using our "Gravity Casting" process. This process ensures a more uniform and robust casting, laying a strong platform to build on. Take a look below at our offerings, surely you will find a head to suit your application.

LS1 LS2 LS6



LS3 L92



Bare | As-Cast

Application	Intake Runner Volume (cc)	Combustion Chamber Volume (cc)	Comp. Valve Job	Intake Valve Diameter (in)	Exhaust Valve Diameter (in)	Valve Angle	Cylinder Head Material	SKU
GM LS1 LS2 LS6	210 cc	62 cc	No	2.020 in.	1.550 in.	15 deg.	Aluminum	PCE281.1455
GM LS3 L92 L76	250 cc	64 cc	Yes	2.200 in.	1.600 in.	15 deg.	Aluminum	PCE281.1482
			No	2.165 in.	1.590 in.			PCE281.1469

Bare | Full-CNC

Application	Intake Runner Volume (cc)	Combustion Chamber Volume (cc)	Comp. Valve Job	Intake Valve Diameter (in)	Exhaust Valve Diameter (in)	Valve Angle	Cylinder Head Material	SKU
GM LS1 LS2 LS6	198 cc	62 cc	No	2.050 in.	1.600 in.	15 deg.	Aluminum	PCE281.1084
			No					PCE281.1085
		64 cc	Yes	2.050 in.	1.600 in.	15 deg.	Aluminum	PCE281.1086
			Yes	2.080 in.	1.550 in.	15 deg.	Aluminum	PCE281.1087
			No	2.050 in.	1.600 in.	15 deg.	Aluminum	PCE281.1088
	225 cc		Yes	2.050 in.	1.600 in.	15 deg.	Aluminum	PCE281.1089
			No	2.050 in.	1.600 in.	15 deg.	Aluminum	PCE281.1090
			No	2.020 in.	1.550 in.	15 deg.	Aluminum	PCE281.1459
			No	2.020 in.	1.550 in.	15 deg.	Aluminum	PCE281.1460
			Yes	2.020 in.	1.550 in.	15 deg.	Aluminum	PCE281.1466
GM LS3 L92	270 cc		Yes	2.050 in.	1.600 in.	15 deg.	Aluminum	PCE281.1463
			No	2.165 in.	1.600 in.	15 deg.	Aluminum	PCE281.1471
			Yes	2.165 in.	1.600 in.	15 deg.	Aluminum	PCE281.1472
	71 cc		Yes	2.200 in.	1.600 in.	15 deg.	Aluminum	PCE281.1475
			No	2.165 in.	1.600 in.	15 deg.	Aluminum	PCE281.1476
			Yes	2.165 in.	1.600 in.	15 deg.	Aluminum	PCE281.1477
			Yes	2.200 in.	1.600 in.	15 deg.	Aluminum	PCE281.1481
GM LS7	256 cc	64 cc	No	2.200 in.	1.600 in.	15 deg.	Aluminum	PCE281.1091
			Yes	2.200 in.	1.600 in.	15 deg.	Aluminum	PCE281.1093
		68 cc	No	2.200 in.	1.600 in.	15 deg.	Aluminum	PCE281.1094
	Yes	2.200 in.	1.600 in.	15 deg.	Aluminum	PCE281.1095		
	Yes	2.200 in.	1.600 in.	15 deg.	Aluminum	PCE281.1098		
	Yes	2.200 in.	1.600 in.	15 deg.	Aluminum	PCE281.1099		

LSX Port Identification

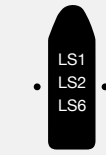

Cathedral Port Center Bolts

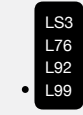

Rectangle Port Low Bolts

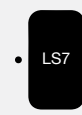

Rectangle Port Center Bolts



Suggested Accessories

Intake / Exhaust Gaskets

Unlike most other Chevy V-8's, the LS-series engines utilize individual O-rings around each port to seal the intake manifold to cylinder head. The LS1 / LS2 / LS6 style heads & manifolds use PCE349.1019 or GM pn# 12533587, the LS3 / L76 / L92 style heads use PCE349.1020 or GM pn# 1290125 and the LS7 style heads use PCE349.1021. On the Exhaust side of the head, all non-LS7 heads utilize the same MLS header gasket. The part number of the exhaust gasket is GM pn# 12901125.

Head Gaskets

Because there are so many different bore sizes for engines in the LS-series, below you will find a list of Speedmaster™ and Fel-Pro head gasket part numbers and their bore size:

Bore Size	Speedmaster™ MLS#	Fel-Pro#
3.945"	PCE348.1013 (pr.)	1160L/R (ea.)
4.050"	PCE348.1016 (pr.)	
4.106"	PCE348.1019 (pr.)	1161L/R (ea.)
4.160"	PCE348.1022 (pr.)	1162L/R (ea.)

These Speedmaster™ MLS head gaskets feature 100% stainless steel construction. We don't use inferior mild steel like some other aftermarket gasket suppliers. To aid in sealing, both outer layers of our MLS gaskets are covered with a high temperature coating. You won't find better value in head gaskets for a LS anywhere.

Head Bolts / Studs

Unlike the early GM heads, Speedmaster™ heads use common length head bolts / studs. Starting in 2002, GM heads went to the same common length head bolt arrangement. By using bolt / stud registers that are all the same thickness, equal clamp load is created all the way around each cylinder. Our part number for the correct head stud kit is PCE279.1022. The ARP part numbers that work with our LS-series heads are # 134-3610 (bolts) and #23-4317 (12pt. stud kits)

Do not RE-USE GM head bolts, They are Torque-to-Yield (TTY) and can only be used once!

Torque the 11mm. bolts / studs to 65lbs and the 8mm bolts / studs to 20lbs. using high pressure moly lubricant.

*Please consult your hardware supplier for their specific torque recommendations!

Spark Plugs

Be careful with your selection of spark plugs in the LS-series engines. The OEM plug is a NGK TR5. We recommend that you use NGK TR6 spark plugs on performance oriented engines. If you require a spark plug colder than a 6 heat range, you will have to switch away from resistor style plugs, and into the NGK R5724-7 or R5724-8. These colder plugs don't have an internal resistor, so they may cause some slight RF interface. Usually it's not a problem unless you have a really sensitive aftermarket ECU, and even then it's not normally a problem. If you prefer Autolite spark plugs, use the AR103 for street / strip performance engines. The AR94 is quite a bit colder for those of you looking to squeeze N20, or heavy boosted engines.



Flow Results

PCE281.1463 These Flow Numbers are with a Performance Valve job Intake Valve - 2.020" Exhaust Valve - 1.600"			PCE281.1475 These Flow Numbers are with a Performance Valve job Intake Valve - 2.200" Exhaust Valve - 1.600"		
LIFT	INTAKE	EXHAUST	LIFT	INTAKE	EXHAUST
0.100	67.9	54.0	0.100	71.5	59.1
0.200	139.0	113.0	0.200	158.7	123.2
0.300	201.1	167.6	0.300	229.8	174.1
0.400	255.7	183.2	0.400	290.6	218.4
0.500	286.1	197.6	0.500	327.3	240.4
0.600	291.5	203.3	0.600	359.5	252.5
0.650	293.3	206.6	0.700	377.4	260.6

Intake Port: 215cc
Exhaust Port: 90cc
Combustion Chamber: 64cc

Intake Port: 270cc
Exhaust Port: 84cc
Combustion Chamber: 68cc



Ford Small Block Windsor

4.7L **289** • 5.0L **302** • 5.8L **351**

One of the best upgrades to your Small Block Ford engine is the replacement of your cast iron head to a better performing and lighter aluminum head. How great is it that you can now do it at a price that's affordable. Our line of Small Block Ford performance heads have proven themselves time and time again both on the track and on the dyno, not to mention countless features in performance magazine articles. We offer Small block ford cylinder heads for a wide range of displacement applications. With bigger displacement engines becoming more common, the need for more airflow is necessary. If you are looking to build a 400-700 horsepower engine then you should consider Speedmaster™ Aluminum cylinder heads. Like the rest of our performance heads we use our "Gravity Die Cast" process. This casting process creates a much more uniform and robust cylinder head. They also offer a smaller cross section to increase the incoming air's velocity resulting in improved drivability, power and economy. We have them available in as cast for the mild street applications and in Fully CNC machined for the serious enthusiast. Speedmaster™ CNC ported cylinder heads are machined on a dedicated 5 axis CNC machining centers to ensure accuracy and cost effectiveness. Combustion chamber, exhaust and intake ports are fully CNC machined for better flow. CNC combustion chambers offer superior control over flame travel and quench area. CNC ported heads eliminate human error and variation from port to port.



OEM

Flow Results

PCE281.1573 These Flow Numbers are as Cast Intake Valve - 2.020" Exhaust Valve - 1.600"			PCE281.1601 These Flow Numbers are CNC Ported Intake Valve - 2.200" Exhaust Valve - 1.600"		
LIFT	INTAKE	EXHAUST	LIFT	INTAKE	EXHAUST
0.100	59.4	50.4	0.100	71.5	59.1
0.200	108.0	102.2	0.200	158.7	123.2
0.300	154.9	145.9	0.300	229.8	174.1
0.400	203.5	159.8	0.400	290.6	218.4
0.500	239.8	166.9	0.500	327.3	240.4
0.600	260.3	169.8	0.600	359.5	252.5
0.700	268.2	170.0	0.700	377.4	260.6
0.750	269.9	170.4			

Intake Port: 195cc
Exhaust Port: 60cc
Combustion Chamber: 64cc

Intake Port: 215cc
Exhaust Port: 60cc
Combustion Chamber: 64cc

Bare | As-Cast

Intake Runner Volume (cc)	Combustion Chamber Volume (cc)	Comp. Valve Job	Intake Valve Diameter (in)	Exhaust Valve Diameter (in)	Valve Angle	Cylinder Head Material	SKU
160 cc	62 cc	No	2.020 in.	1.600 in.	20 deg.	Aluminum	PCE281.1533 (**)
175 cc	62 cc	No	2.020 in.	1.600 in.	20 deg.	Aluminum	PCE281.1539
180 cc	60 cc	No	1.940 in.	1.600 in.	20 deg.	Cast Iron	PCE281.1761
190 cc	62 cc	No	2.020 in.	1.600 in.	20 deg.	Aluminum	PCE281.1556
210 cc	62 cc	No	2.020 in.	1.600 in.	20 deg.	Aluminum	PCE281.1573

(**) = OEM Replacement with EGR Passage

Bare | Full-CNC

Intake Runner Volume (cc)	Combustion Chamber Volume (cc)	Comp. Valve Job	Intake Valve Diameter (in)	Exhaust Valve Diameter (in)	Valve Angle	Cylinder Head Material	SKU
		No	2.020 in.	1.600 in.	20 deg.	Aluminum	PCE281.1601
			2.020 in.				PCE281.1629
227 cc	64 cc	Yes	2.055 in.	1.600 in.	20 deg.	Aluminum	PCE281.1617
			2.080 in.				PCE281.1641

Suggested Accessories

* Ford 289 / 302 / 5.0L based engines with 7 / 16" Head Bolts / Studs, we offer the required hardened shoulder spacers to keep the bolt or nut from deforming the aluminum head. the part number is PCE281.1532.

Intake / Exhaust Gaskets

Although our Small Block Ford cylinder heads fit on both 289 / 302 / 5.0L and 351W blocks, they use the same manifold to head gaskets, but require specific valley gaskets that are purchased separately from some aftermarket suppliers. Speedmaster™ PCE349.1006 comes with both lengths of valley gaskets as well as the manifold to head gaskets. Fel-pro has specific part numbers for each layout. Fel-Pro pn# 1262 is the manifold to head gasket that fits both engines. If you require a thicker gasket, or have our CNC ported heads, use Felpro pn# 1262R.

For the exhaust gaskets, use our PCE355.1002 which is a re-usable copper gasket set, or Felpro pn# 1487 which is a paper gasket set.

Head Gaskets

Due to the popularity of the Small Block Ford engines, there are many different bore size gaskets available. The following is a small list of gaskets we recommend for use with our SBF cylinder heads:

Speedmaster™ PCE348.1007 (4.055" Bore size .041" thick, MLS) Speedmaster™ PCE348.1008 (4.185" Bore size .041" thick, MLS)

Fel-Pro PN# 9333-PT1 (standard low performance use) Fel-Pro PN# 1011-2 (4.100" Bore size, .039" thick, Comp.)
 Fel-Pro PN# 1006 (4.145" Bore size, .039" thick, Comp.) Fel-Pro PN# 1046 (4.200" Bore size, .051" thick, Comp.)
 Fel-Pro PN# 1133 (4.100" Bore size, .041" thick, MLS.) Fel-Pro PN# 1134 (4.185" Bore size, .041" thick, MLS.)
 Fel-Pro PN# 1135 (4.200" Bore size, .041" thick, MLS.)

Head Bolts / Studs

Our heads don't require anything special as far as head bolts are concerned. We do however recommend that you replace your fasteners when installing a new set of heads.

289 / 302 / 5.0L engines use 7/16" hardware like the following for use w/ PCE281.1532 adapters: Speedmaster™ PCE279.1010 (head stud kit), ARP pn# 154-3605 (head bolt kit) or ARP pn# 154-4205 (head stud kit).

351W engines use 1/2" hardware like the following: Speedmaster™ PCE279.1012 (head stud kit), ARP pn# 154-3603 (head bolt kit) or ARP pn# 154-4203 (head stud kit).

Spark Plugs

Our Small Block Ford cylinder heads require the use of a14mm thread, 5 / 8" hex, .750" reach spark plugs. Below you will find a list of some plugs that fit and work with our heads:

NGK - BCPR6ES, R5671A-7, R5671A-8 Autolite - 3923, 3924, AR3933, AR3934 Champion - RC12YC, RC10YC74, RC9YC3

Remember that you need a COLDER plug when you make more power, ie. N2O, turbo and supercharging.

Assembled & DIY

Intake Runner Volume (cc)	Combustion Chamber Volume (cc)	Heads Type	Comp. Valve Job	Camshaft Type	Assembled SKU	DIY SKU
175 cc	62 cc	As Cast	No	Hydraulic Flat Tappet	PCE281.2043	PCE281.1043
				Hydraulic Roller	PCE281.2045	PCE281.1045
				Solid Flat Tappet	PCE281.2044	PCE281.1044
190 cc	62 cc	As Cast	No	Hydraulic Flat Tappet	PCE281.2046	PCE281.1046
				Hydraulic Roller	PCE281.2048	PCE281.1048
				Solid Flat Tappet	PCE281.2047	PCE281.1047
210 cc	62 cc	As Cast	No	Hydraulic Flat Tappet	PCE281.2049	PCE281.1049
				Hydraulic Roller	PCE281.2051	PCE281.1051
				Solid Flat Tappet	PCE281.2050	PCE281.1050
227 cc	64 cc	Full CNC	No	Hydraulic Roller	PCE281.2053	PCE281.1053
				Solid Flat Tappet	PCE281.2052	PCE281.1052
				Solid Roller	PCE281.2054	PCE281.1054
				Hydraulic Roller	PCE281.2056	PCE281.1056
				Solid Flat Tappet	PCE281.2055	PCE281.1055
			Yes	Solid Roller	PCE281.2057	PCE281.1057



Ford Cleveland

5.8L 351

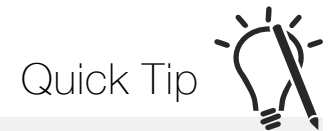

The Speedmaster™ Ford Cleveland 3v heads are a perfect upgrade for both 2 and 4 barrel engines. We have re-designed the intake ports by raising the floor to help cut down on the massive cross-section that hampers OEM 4 barrel heads. Not only do you get more performance out of the box than OEM heads, our heads are significantly lighter since they are made of "Gravity Die Cast" aluminum. As another benefit, you can run higher compression with aluminum heads before the onset of power robbing detonation. There is absolutely no reason to rebuild a set of OEM castings when you can buy a lighter, higher flowing and more detonation resistant cylinder head for less money from us! To top it all off, we offer CNC ported Cleveland heads for people looking for even more performance.



Flow Results

PCE281.1703 These Flow Numbers are as Cast Intake Valve - 2.19" Exhaust Valve - 1.71"			PCE281.1724 These Numbers are CNC Ported Intake Valve - 2.190" Exhaust Valve - 1.710"		
LIFT	INTAKE	EXHAUST	LIFT	INTAKE	EXHAUST
0.100	45.1	41.3	0.100	68.4	58.4
0.200	92.1	86.4	0.200	140.8	106.1
0.300	152.0	131.0	0.300	200.3	147.4
0.400	211.4	162.9	0.400	253.9	185.4
0.500	252.1	180.0	0.500	296.2	216.1
0.600	275.4	189.2	0.600	320.6	240.5
0.700	290.6	191.8	0.700	339.2	256.9
0.800	284.9	193.7	0.800	350.3	265.1

Intake Port: 210cc
Exhaust Port: 110cc
Combustion Chamber: 74cc

Intake Port: 233cc
Exhaust Port: 120cc
Combustion Chamber: 74cc



In the past they discovered that inserting tongues in a 4V straightened out the flow and actually picked up horsepower, despite the port being smaller. This is the principle behind 3vs. The secret to 3Vs flowing more despite being smaller is in the velocity, having higher speed through the port keeps momentum up and fills the cylinder more efficiently.



Suggested Accessories

Intake / Exhaust Gaskets

Due to the unique raised port of the Speedmaster™ 3v head, the only intake gaskets readily available are Speedmaster™ PCE349.1001 which measure 1.73(W) x 2.140(T) with the floor of the port 1.220" up from the deck of the head.

The exhaust side of the head uses standard 4v exhaust gaskets. You can use Speedmaster™ PCE355.1010 or Fel-Pro 1416 header gaskets which measure 1.89" (W) x 2.19" (T).

Head Gaskets

The Speedmaster™ PCE281.1703, PCE281.1714, PCE281.1724 and PCE281.1726 cylinder heads use the following head gaskets for use with 351C block:

- Speedmaster™ PCE348.1005 (MLS 4.055" gasket bore)
- Fel-Pro 1013 (Composite 4.100" gasket bore)

Both gaskets are .040" thickness when compressed.

Head Bolts / Studs

The Speedmaster™ Cleveland 3v heads require specific head studs that are longer than standard.

Use Speedmaster™ PCE279.1014.

These studs should only be finger tightened into the block. Torque the nuts to 65lbs. using high pressure moly lube, in increments of 15lbs.

Spark Plugs

Our Ford Cleveland cylinder heads require the use of a 14mm. thread 5/8" hex, .750" reach spark plugs. Below you will find a list of some plugs that fit and work with our heads:

- NGK - BCPR6ES, R5671A-7, R5671A-8
- Autolite - 3923, 3924, AR3933, AR3934
- Champion - RC12YC, RC10YC4, RC9YC3

Remember that you need a COLDER plug when you make more power, ie. N2O, Turbo and supercharging.

Bare | As-Cast

Intake Runner Volume (cc)	Combustion Chamber Volume (cc)	Comp. Valve Job	Intake Valve Diameter (in)	Exhaust Valve Diameter (in)	Valve Angle	Cylinder Head Material	SKU
220 cc	64 cc	No	2.190 in.	1.710 in.	Standard	Aluminum	PCE281.1703
		Yes					PCE281.1714

Bare | Full-CNC

Intake Runner Volume (cc)	Combustion Chamber Volume (cc)	Comp. Valve Job	Intake Valve Diameter (in)	Exhaust Valve Diameter (in)	Valve Angle	Cylinder Head Material	SKU
235 cc	68 cc	No	2.190 in.	1.710 in.	Standard	Aluminum	PCE281.1724
		Yes					PCE281.1726

Assembled & DIY

Intake Runner Volume (cc)	Combustion Chamber Volume (cc)	Heads Type	Comp. Valve Job	Camshaft Type	Assembled SKU	DIY SKU
220 cc	64 cc	As Cast	No	Hydraulic Flat Tappet	PCE281.2058	PCE281.1058
				Hydraulic Roller	PCE281.2060	PCE281.1060
				Solid Flat Tappet	PCE281.2059	PCE281.1059
		Full CNC		Hydraulic Roller	PCE281.2062	PCE281.1062
				Solid Flat Tappet	PCE281.2061	PCE281.1061
				Solid Roller	PCE281.2063	PCE281.1063
235 cc	68 cc	Full CNC	Yes	Hydraulic Roller	PCE281.2065	PCE281.1065
				Solid Flat Tappet	PCE281.2064	PCE281.1064
				Solid Roller	PCE281.2066	PCE281.1066



Ford Big Block

7.0L 429 • 7.5L 460

Speedmaster™ performance aluminum cylinder heads are also available for the Big Block Ford enthusiasts. With bigger displacement engines becoming more common, the need for more airflow is necessary. If you are looking to build a 400-700 horsepower engine then you should consider Speedmaster™ Aluminum cylinder heads. Like the rest of our performance heads we use our "Gravity Die Cast" process. This casting process creates a much more uniform and robust cylinder head. They also offer a smaller cross section to increase the incoming air's velocity resulting in improved drivability, power and economy. We have them available in as cast for the mild street applications and in Fully CNC machined for the serious enthusiast. Speedmaster™ CNC ported cylinder heads are machined on a dedicated 5 axis CNC machining centers to ensure accuracy and cost effectiveness. Combustion chamber, exhaust and intake ports are fully CNC machined for better flow. CNC combustion chambers offer superior control over flame travel and quench area. CNC ported heads eliminate human error and variation from port to port.



Flow Results

PCE281.1657 These Flow Numbers are as Cast Intake Valve - 2.190" Exhaust Valve - 1.710"			PCE281.1683 These Flow Numbers are CNC Ported Intake Valve - 2.190" Exhaust Valve - 1.710"		
LIFT	INTAKE	EXHAUST	LIFT	INTAKE	EXHAUST
0.100	65.5	50.0	0.100	72.0	60.0
0.200	107.0	85.0	0.200	152.0	110.0
0.300	162.0	122.0	0.300	219.0	145.0
0.400	208.0	145.0	0.400	280.0	180.0
0.500	245.0	160.0	0.500	331.0	204.0
0.600	267.0	167.0	0.600	344.0	225.0
0.700	295.0	175.0	0.700	350.0	240.0

Intake Port: 275cc
Exhaust Port: 90cc
Combustion Chamber: 95cc

Intake Port: 300cc
Exhaust Port: 94cc
Combustion Chamber: 98cc



Bare | As-Cast

Intake Runner Volume (cc)	Combustion Chamber Volume (cc)	Comp. Valve Job	Intake Valve Diameter (in)	Exhaust Valve Diameter (in)	Valve Angle	Cylinder Head Material	SKU
275 cc	95 cc	No	2.190 in.	1.710 in.	Standard	Aluminum	PCE281.1657
		Yes	2.190 in.				PCE281.1667

Bare | Full-CNC

Intake Runner Volume (cc)	Combustion Chamber Volume (cc)	Comp. Valve Job	Intake Valve Diameter (in)	Exhaust Valve Diameter (in)	Valve Angle	Cylinder Head Material	SKU
300 cc	98 cc	No	2.190 in.	1.710 in.	Standard	Aluminum	PCE281.1683
		Yes	2.190 in.	1.760 in.			PCE281.1693

Suggested Accessories

Intake / Exhaust Gaskets

Our Big Block Ford cylinder heads are designed to use Ford Cobra Jet manifolds and headers. Due to the diameter of the intake ports, you can't use a standard Ford 460 intake manifold gasket. We recommend that you use Speedmaster™ PCE349.1009 intake gaskets. If you prefer Fel-Pro, use their pn#1231 gaskets.

For the exhaust side, use speedmaster™ PCE355.1009 or Fel-Pro pn# 1420. The Fel-Pro pn# 1420 is a paper gasket.

Head Gaskets

These heads use the same head gaskets as an OEM Ford Cobra Jet head. Because we don't currently make our own head gaskets for this family of engines (385 series), we recommend that you use Fel-Pro pn# 1018 on engines under 4.500" bore.

Check back often as we are currently developing a MLS head gasket to meet the needs of serious Ford performance junkies.

Head Bolts / Studs

As you are probably aware, the factory head bolts are 9 / 16" diameter on BBF engines. The torque value on 9 / 16" head bolts or head studs is 145lbs with high pressure moly lube. Start with 70lbs and tighten the head down in 25lb increments until you reach 145lbs.

The part number for the Ford 460 Speedmaster™ Head Stud Kit is PCE279.1015. Fel-Pro makes both head bolt kits and head stud kits, their part number for the head bolt kit is 155 - 4203 and the stud kit is 255 - 3701 SPARK PLUGS

Spark Plugs

Our Big Block Ford cylinder heads require the use of a 14mm thread 5 / 8" hex, .750" reach spark plugs. Below you will find a list of some plugs that fit and work with our heads:

NGK - BCPR6ES, R5671A-7, R5671A-8
Autolite - 3923, 3924, AR3933, AR3934
Champion - RC12YC, RC10YC4, RC9YC3

Remember that you need a COLDER plug when you make more power. i.e N2O, turbo and supercharging

Assembled & DIY



Intake Runner Volume (cc)	Combustion Chamber Volume (cc)	Heads Type	Comp. Valve Job	Camshaft Type	Assembled SKU	DIY SKU
275 cc	95 cc	As Cast	No	Hydraulic Flat Tappet	PCE281.2075	PCE281.1075
				Hydraulic Roller	PCE281.2077	PCE281.1077
				Solid Flat Tappet	PCE281.2076	PCE281.1076
300 cc	98 cc	Full CNC	No	Hydraulic Roller	PCE281.2079	PCE281.1079
				Solid Flat Tappet	PCE281.2078	PCE281.1078
				Solid Roller	PCE281.2080	PCE281.1080

Holden

5.0L 253 • 5.0L 304 • 5.0L 308

Speedmaster™ V8 Holden VN cylinder head is a definite step above the rest. We utilize high flow ports and larger diameter hardened seats that offer improved flow and increased longevity when used with today's low lead fuels. Not only do you get more performance out of the box than OEM heads, our heads are significantly lighter since they are made of "Gravity Die Cast" Aluminum. There is absolutely no reason to rebuild your set of OEM castings when you can use a higher flowing, lighter, more detonation resistant cylinder head. You won't find a head that offers better value. Period.



Flow Results

PCE281.1735 These Flow Numbers are as Cast Intake Valve - 2.02" Exhaust Valve - 1.60"			PCE281.1738 These Flow Numbers are CNC Ported Intake Valve - 2.02" Exhaust Valve - 1.60"		
LIFT	INTAKE	EXHAUST	LIFT	INTAKE	EXHAUST
0.100	69.3	46.0	0.100	69.3	46.0
0.200	126.6	99.2	0.200	126.6	99.2
0.300	177.0	131.3	0.300	177.0	131.3
0.400	210.2	149.3	0.400	210.2	149.3
0.500	226.1	160.9	0.500	226.1	160.9
0.600	232.4	167.5	0.600	232.4	167.5
0.700	236.1	171.7	0.700	236.1	171.7
0.800	237.5	172.9	0.800	237.5	172.9

Intake Port: 195cc
Combustion Chamber: 64cc

Intake Port: 205cc
Combustion Chamber: 66cc

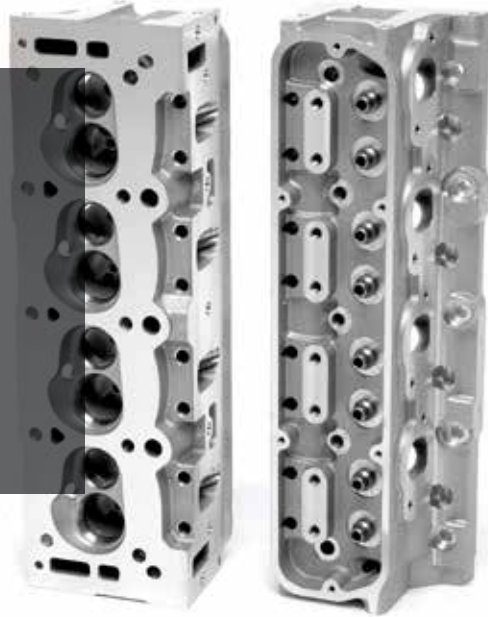

Bare | As-Cast

Intake Runner Volume (cc)	Combustion Chamber Volume (cc)	Comp. Valve Job	Intake Valve Diameter (in)	Exhaust Valve Diameter (in)	Valve Angle	Cylinder Head Material	SKU
195 cc	64 cc	No	2.020 in.	1.600 in.	Standard	Aluminum	PCE281.1735 *
205 cc	68 cc	No	2.020 in.	1.600 in.	Standard	Aluminum	PCE281.1737

Bare | Full-CNC

Intake Runner Volume (cc)	Combustion Chamber Volume (cc)	Comp. Valve Job	Intake Valve Diameter (in)	Exhaust Valve Diameter (in)	Valve Angle	Cylinder Head Material	SKU
205 cc	68 cc	Yes	2.020 in.	1.600 in.	Standard	Aluminum	PCE281.1738 *

* = Steel Guides

Suggested Accessories

Intake / Exhaust Gaskets

The Speedmaster™ heads are designed around using factory replacement gaskets.

We offer two different styles of intake gaskets. The Speedmaster™ PCE349.1017 is a paper style gasket for people looking for the lowest cost option, or head porters that are want a plain gasket they can trim to fit enlarged ports. We also have a premium Printed Sealer type gasket, Speedmaster™ PCE349.1016.

Head Gaskets

Because our VN head is designed as a performance replacement for the factory head, you can use any OEM style head gaskets.

We prefer our Speedmaster™ MLS head gasket PCE348.1027. With all stainless construction, you won't find a better gasket anywhere!

If you prefer Fel-Pro, use Fel-Pro # 1059 head gaskets.

Head Bolts / Studs

The head bolts / studs required are the same as factory Holden heads.

Speedmaster™ offers a 190,000 psi. head stud kit to suit our VN perfectly! the part number is PCE279.1020

ARP also offers both head bolts and head stud kits. Their head bolt kit is #205-3601 and the head stud kit is # 205-4601. Be careful to torque the heads following the OEM sequence in 3 steps to a final torque setting of 65lbs. using high pressure molly lube under the nuts and on the exposed threads of the studs.

Spark Plugs

Our Holden 304-308 cylinder heads require the use of a 14m. thread, 5/8" hex, .750" reach spark plug. Below you will find a list of some plugs that fit and work with our heads:

NGK - BCPR6ES, R5671A-7, R5671A-8
Autolite - 3923, 3924, AR3933, AR3934
Champion - RC12YC, RC10YC4, RC9YC3

Remember that you need a COLDER plug when you make more power, ie. N2O, Turbo and Supercharging!



Assembled & DIY

Intake Runner Volume (cc)	Combustion Chamber Volume (cc)	Heads Type	Comp. Valve Job	Lock Style	Camshaft Type	Assembled SKU	DIY SKU
195 cc	64 cc	As Cast	No	7 degree	Hydraulic Flat Tappet	PCE281.2067	PCE281.1067
					Hydraulic Roller	PCE281.2070	PCE281.1070
				10 degree	Hydraulic Flat Tappet	PCE281.2068	PCE281.1068
					Hydraulic Roller	PCE281.2071	PCE281.1071
205 cc	68 cc	Full CNC	Yes	7 degree	Solid Flat Tappet	PCE281.2069	PCE281.1069
					Hydraulic Roller	PCE281.2073	PCE281.1073
				10 degree	Hydraulic Roller	PCE281.2074	PCE281.1074
					Solid Flat Tappet	PCE281.2072	PCE281.1072

Chrysler

2.2L/2.5L 4cyl • 5.2L 318 • 5.6L 340 • 5.9L 360 • 6.3L 383 • 7.2L 440

All Speedmaster™ alloy cylinder heads are made using a superior “gravity die” cast process. These heads are flow tested on a Superflow SF600 at 28 inches with a 1/2 inch radius intake plate and short stack exhaust tube.

4 Cyl 2.2L 2.5L



SB 318 340 360 - Aluminum



BB 383 440



Iron

Flow Results

PCE281.1728 These Flow Numbers are as Cast Intake Valve - 2.200" Exhaust Valve - 1.810"			PCE281.1731 These Flow Numbers are CNC Ported Intake Valve - 2.200" Exhaust Valve - 1.810"		
LIFT	INTAKE	EXHAUST	LIFT	INTAKE	EXHAUST
0.100	71.1	54.1	0.100	69.3	57.4
0.200	146.2	103.9	0.200	147.5	116.8
0.300	207.9	150.0	0.300	217.8	159.0
0.400	251.2	187.0	0.400	278.3	211.8
0.500	273.6	213.2	0.500	319.7	241.6
0.600	287.2	229.8	0.600	343.9	269.0
0.700	296.0	239.4	0.700	357.2	287.7
0.800	294.8	246.4	0.800	364.5	299.8

Intake Port: 265cc
Combustion Chamber: 78cc

Intake Port: 285cc
Combustion Chamber: 72cc



Bare | As-Cast

Application	Intake Runner Volume (cc)	Combustion Chamber Volume (cc)	Comp. Valve Job	Intake Valve Diameter (in)	Exhaust Valve Diameter (in)	Cylinder Head Material	SKU
4 Cyl 2.2L 2.5L	OEM	OEM	No	-	-	Aluminum	PCE281.1776
SB 318 340 360	179 cc	62 cc	No	1.920 in.	1.625 in.	Cast Iron	PCE281.1773
			Yes	2.020 in.			PCE281.1774
	170 cc	65 cc	No	2.020 in.	1.620 in.	Aluminum	PCE281.1775
			Yes				PCE281.1654
BB 383 440	265 cc	74 cc	No	2.200 in.	1.810 in.	Aluminum	PCE281.1655

Bare | Full-CNC

Application	Intake Runner Volume (cc)	Combustion Chamber Volume (cc)	Comp. Valve Job	Intake Valve Diameter (in)	Exhaust Valve Diameter (in)	Cylinder Head Material	SKU
SB 318 340 360	190 cc	68 cc	No	2.020 in.	1.620 in.	Aluminum	PCE281.1656
			Yes				PCE281.1658
BB 383 440	325 cc	78 cc	No	2.200 in.	1.810 in.	Aluminum	PCE281.1731
			Yes				PCE281.1733



Suggested Accessories

Intake / Exhaust Gaskets

4-cyl. 2.2 / 2.5:
Intake / Exhaust - MS90947

Chrysler 400:
Intake - Fel Pro 1216
Exhaust - Fel Pro 1414
(May need a small amount of trimming)

Chrysler 318 - 360: (PCE281.1773) Cast Iron
Intake - Mopar #4876049
Exhaust - Mopar #MS95480

Chrysler 318 - 360: (PCE281.1654) Aluminum
Intake - PCE349.1010 or FelPro 1213
Exhaust - SM3275 or Felpro 1413

Head Gaskets

The PCE281.1776 4-cyl. head is designed around an OEM head gasket. Use Mopar # P4452006. We recommend you use Fel Pro head gaskets under our Speedmaster™ PCE281.1728, PCE281.1731 & PCE281.1733 heads. Use Fel P5ro #1009 or 1105 (big bore) On Speedmaster™ PCE281.1773 we recommend the Fel Pro #519SD (on Magnum Engines), or #1008 (on LA-series Engines). For the new Speedmaster™ PCE281.1654 Aluminum heads, we only recommend using Speedmaster™ PCE348.1010 or Felpro #1008 head gaskets.

Head Bolts / Studs

For the PCE281.1776 4-cyl. head, use ARP #241-3701 (bolts) or #241-4701 (studs), and follow ARP's recommended torque values. Also, make sure you follow the OEM torque sequence! For the PCE281.1728, PCE281.1731 and PCE281.1733 use Speedmaster™ head stud kit PCE279.1018. Torque to 65lbs. using high pressure Moly lube on the threads and under the heads. The Arp #'s for the Big Block 440 heads are #145-3609 (bolts) and #145-4206 (studs) For the Small Block Chrysler heads, use Speedmaster™ PCE279.1017 head stud kit and torque the heads to 65lbs with Moly Lube.

Spark Plugs

For the 4-cyl. Chrysler head, use the following: Autolite 65, or AP65 Champion RN12YC or 3405 NGK GR4 or GR4GP

For the V8 Chrysler heads, the following is a small list of spark plugs you can use: NGK - BCPR6ES, R5671A-7, R5671A-8 Autolite - 3923, 3924, AR3933, AR3934 Champion - RC12YC, RC10YC4, RC9YC3

Remember that you need a COLDER plug when you make more power, ie. N2O, turbo and Supercharging

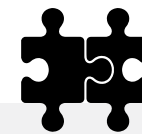

Assembled & DIY

Application	Intake Runner Volume (cc)	Combustion Chamber Volume (cc)	Heads Type	Comp. Valve Job	Camshaft Type	Assembled SKU	DIY SKU
SB 318 340 360	170 cc	65 cc	As Cast	No	Hydraulic Flat Tappet	PCE281.2146	PCE281.1146
					Hydraulic Roller	PCE281.2149	PCE281.1149
				Yes	Hydraulic Flat Tappet	PCE281.2147	PCE281.1147
	190 cc	68 cc	CNC	No	Hydraulic Flat Tappet	PCE281.2150	PCE281.1150
					Hydraulic Roller	PCE281.2148	PCE281.1148
				Yes	Hydraulic Flat Tappet	PCE281.2151	PCE281.1151
BB 383 440	265 cc	74 cc	As Cast	No	Hydraulic Flat Tappet	PCE281.2140	PCE281.1140
					Hydraulic Roller	PCE281.2141	PCE281.1141
				Yes	Hydraulic Flat Tappet	PCE281.2142	PCE281.1142
	325 cc	78 cc	CNC	No	Hydraulic Roller	PCE281.2143	PCE281.1143
				Yes	Hydraulic Flat Tappet	PCE281.2144	PCE281.1144
					Hydraulic Roller	PCE281.2145	PCE281.1145

Oldsmobile

6.6L 400 • 7.0L 425 • 7.5L 455

These Speedmaster™ Oldsmobile V8 aluminum cylinder heads feature threaded inserts in the rocker studs and exhaust manifold bolt holes for superior strength and durability. They also feature hardened seats, bronze valve guides, and fully machined valve cover rails for a more consistent gasket seal. They offer improved power throughout the rpm range for greater throttle response and top-end horsepower.



Bare | As-Cast

Intake Runner Volume (cc)	Combustion Chamber Volume (cc)	Comp. Valve Job	Intake Valve Diameter (in)	Exhaust Valve Diameter (in)	Cylinder Head Material	SKU
188 cc	77 cc	No	2.072 in.	1.680 in.	Aluminum	PCE281.1740

Honda & Toyota 4 Cylinder

All Speedmaster™ alloy cylinder heads are made using a superior "gravity die cast" process. These heads are flow tested on a Superflow SF600 at 28 inches with a 1/2 inch radius intake plate and short stack exhaust tube. All Speedmaster CNC Cylinder heads have been professionally CNC Ported in-house with the Rottler P55, our revolutionary 5 Axis CNC Cylinder Head Porting Machine.

Honda 4 Cyl B16A Vtec

Toyota 4Cyl 22R 22Re



Bare | As-Cast

Application	Cylinder Head Material	SKU
Honda 4 Cyl B16A Vtec	Aluminum	PCE281.1780
Toyota 4Cyl 22R 22Re	Aluminum	PCE281.1777

Bare | Full-CNC

Application	Cylinder Head Material	SKU
Honda 4 Cyl B16A Vtec	Aluminum	PCE281.1781

Chrysler-Hemi Extreme Performance



Speedmaster™ Blacklabel 100% CNC ported billet heads, are the result of countless hours of R&D, in house and on the track. Crew Chief's and tuners are able to achieve much greater consistency, through the superior materials, technology, and man-power. Supplying the performance to set records, win races, and clinch Championships.

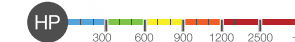

Application	Cylinder Head Material	SKU
Alcohol Stage VI	Billet Aluminum	PCE281.1101
Top Fuel Stage VI	Billet Aluminum	PCE281.1100

Speedmaster™ Blacklabel cylinder heads are designed to support extreme conditions up to **8,000 hp!**



The Blacklabel Series from Speedmaster™ is a symbol for extreme performance.

Through research and development, Speedmaster™ has designed a range of products under the Blacklabel insigne. With products engineered only for drag racing applications, in which the Speedmaster's Chief of Research and Development says that they are parts built for extreme performance.

Cylinder Head Valvetrain Kits

Finest Premium Components

A.K.A Head Build Kits

Speedmaster™ cylinder head parts kits have been assembled with the finest premium components to provide your engine with optimal airflow for maximum engine performance. Head Build Kits include the following: Intake Valves, Exhaust Valves, Valve Spring Retainers, Valve Locks, Valve Springs, Valve Stem Seals, and Valve Spring Locators.

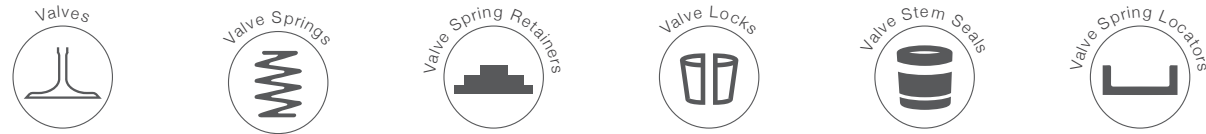

Specifications

	Hydraulic Flat Tappet	Solid Flat Tappet	Hydraulic Roller	Solid Roller	Race Solid Roller
Closed Seat Pressure	110 lbs.	125 lbs.	145 lbs.	210 lbs.	300 lbs.
Open Seat Pressure	300 lbs.	320 lbs.	360 lbs.	450 lbs.	700 lbs.
Max Lift	0.550 in.	0.580 in.	0.580 in.	0.650 in.	0.800 in.

Application	Camshaft Type	SKU	
Chevrolet SBC 350	Hydraulic Flat Tappet	PCE250.1010	
	Solid Flat Tappet	PCE250.1011	
	Hydraulic Roller	PCE250.1012	
	Solid Roller	PCE250.1013	
	Race Solid Roller	PCE250.1014	
Chevrolet SBC 350 - 15 Degree	Hydraulic Flat Tappet	PCE250.1040	
	Solid Flat Tappet	PCE250.1041	
	Hydraulic Roller	PCE250.1042	
	Solid Roller	PCE250.1043	
	Race Solid Roller	PCE250.1044	
Chevrolet BBC 454	Hydraulic Flat Tappet	PCE250.1017	
	Solid Flat Tappet	PCE250.1018	
	Hydraulic Roller	PCE250.1019	
	Solid Roller	PCE250.1020	
	Race Solid Roller	PCE250.1021	
GM LS1 LS2 LS6	Hydraulic Flat Tappet	PCE250.1029	
	Solid Flat Tappet	PCE250.1045	
	Hydraulic Roller	PCE250.1028	
	Solid Roller	PCE250.1046	
	Race Solid Roller	PCE250.1047	
GM LS3 L92	Hydraulic Flat Tappet	PCE250.1048	
	Solid Flat Tappet	PCE250.1049	
	Hydraulic Roller	PCE250.1050	
	Solid Roller	PCE250.1051	
	Race Solid Roller	PCE250.1052	
Holden 253 304 308	7°	Hydraulic Flat Tappet	PCE250.1003
		Solid Flat Tappet	PCE250.1053
		Hydraulic Roller	PCE250.1004
		Solid Roller	PCE250.1054
	10°	Race Solid Roller	PCE250.1055
		Hydraulic Flat Tappet	PCE250.1015
		Solid Flat Tappet	PCE250.1027
		Hydraulic Roller	PCE250.1016

Application	Camshaft Type	SKU
Ford SB 289 302 351 Windsor	Hydraulic Flat Tappet	PCE250.1010
	Solid Flat Tappet	PCE250.1011
	Hydraulic Roller	PCE250.1012
	Solid Roller	PCE250.1013
	Race Solid Roller	PCE250.1014
Ford 302 351C Cleveland	Hydraulic Flat Tappet	PCE250.1005
	Solid Flat Tappet	PCE250.1006
	Hydraulic Roller	PCE250.1007
	Solid Roller	PCE250.1008
	Race Solid Roller	PCE250.1009
Ford 429 460	Hydraulic Flat Tappet	PCE250.1022
	Solid Flat Tappet	PCE250.1023
	Hydraulic Roller	PCE250.1024
	Solid Roller	PCE250.1025
	Race Solid Roller	PCE250.1026
Mopar Chrysler SB 318 340 360	Hydraulic Flat Tappet	PCE250.1038
	Solid Flat Tappet	PCE250.1059
	Hydraulic Roller	PCE250.1039
	Solid Roller	PCE250.1060
	Race Solid Roller	PCE250.1061
Mopar Chrysler BB 383 440	Hydraulic Flat Tappet	PCE250.1035
	Solid Flat Tappet	PCE250.1056
	Hydraulic Roller	PCE250.1036
	Solid Roller	PCE250.1057
	Race Solid Roller	PCE250.1058

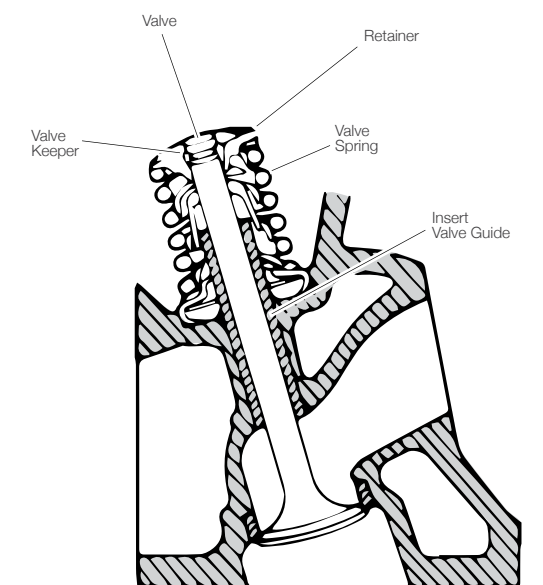

Valvetrain

Valves

When it's time for valves don't cut corners, get genuine Speedmaster™ stainless steel valves. They're made from a tough, stainless steel alloy and are carefully designed to increase fuel flow for more power. Speedmaster™ valves are lightweight, one-piece valves forged from premium stainless steel. They will improve power and withstand both the stresses and the high temperatures of performance engines. In addition to being made from high-quality materials, they have hardened stem tips for durability, swirl-polished and fully machined.



Smooth gas flow



Avoid long term distortions



Greater smoothness

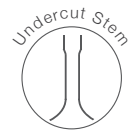

Less weight & better flow

Application	Valve Location	Valve Head Diameter (in)	Valve Installed Length	Overall Valve Length (in)	Valve Stem Diameter (in)	Valve Tip Length (in)	SKU	
Chevrolet SBC 350 23 Deg	Exhaust	1.500 in.	Stock	4.951 in.	11/32 in. (0.344 in.)	0.250 in.	PCE273.1012	
			Stock	4.951 in.			PCE273.1001	
	Exhaust	1.600 in.	0.100 in. over	5.051 in.	11/32 in. (0.344 in.)	0.250 in.	PCE273.1003	
			0.200 in. over	5.151 in.			PCE273.1002	
	Intake	1.940 in.	Stock	4.951 in.	11/32 in. (0.344 in.)	0.250 in.	PCE273.1011	
			Stock	4.951 in.			PCE273.1004	
	Intake	2.020 in.	0.100 in. over	5.051 in.	11/32 in. (0.344 in.)	0.250 in.	PCE273.1006	
			0.200 in. over	5.151 in.			PCE273.1005	
	Chevrolet SBC 350 15 Deg	Exhaust	2.055 in.	0.100 in. over	5.051 in.	11/32 in. (0.344 in.)	0.250 in.	PCE273.1007
			2.080 in.					PCE273.1008
Chevrolet SBC 350 15 Deg	Exhaust	1.600 in.	0.500 in. over	5.450 in.	11/32 in. (0.344 in.)	0.250 in.	PCE273.1065	
	Intake	2.180 in.	0.500 in. over	5.450 in.	11/32 in. (0.344 in.)	0.250 in.	PCE273.1066	
Chevrolet BBC 454	Exhaust	1.880 in.	Stock	5.422 in.	11/32 in. (0.344 in.)	0.220 in.	PCE273.1017	
			0.100 in. over	5.522 in.	11/32 in. (0.344 in.)	0.220 in.	PCE273.1018	
	Exhaust	1.900 in.	Stock	5.522 in.	11/32 in. (0.344 in.)	0.220 in.	PCE273.1019	
		1.940 in.	Stock	5.422 in.	11/32 in. (0.344 in.)	0.220 in.	PCE273.1020	
	Intake	2.190 in.	Stock	5.244 in.	11/32 in. (0.344 in.)	0.220 in.	PCE273.1021	
			0.100 in. over	5.344 in.			PCE273.1022	
	Intake	2.250 in.	0.100 in. over	5.344 in.	11/32 in. (0.344 in.)	0.220 in.	PCE273.1024	
			0.250 in. over	5.494 in.			PCE273.1025	
	Intake	2.300 in.	Stock	5.244 in.			PCE273.1026	
			0.100 in. over	5.344 in.	11/32 in. (0.344 in.)	0.220 in.	PCE273.1027	
		0.250 in. over	5.494 in.			PCE273.1028		

Application	Valve Location	Valve Head Diameter (in)	Valve Installed Length	Overall Valve Length (in)	Valve Stem Diameter (in)	Valve Tip Length (in)	SKU
GM LS1 LS6	Exhaust	1.570 in.	Stock	4.930 in.	8.000mm (0.314 in.)	0.170 in.	PCE273.1013
		1.620 in.					PCE273.1015
	Intake	2.020 in.	0.100 in. over	5.000 in.	8.000mm (0.314 in.)	0.170 in.	PCE273.1036
		2.055 in.	Stock	4.900 in.	8.000mm (0.314 in.)	0.170 in.	PCE273.1016
			0.100 in. over	5.000 in.			PCE273.1034
GM LS3	Exhaust	2.080 in.	Stock	4.900 in.	8.000mm (0.314 in.)	0.170 in.	PCE273.1014
			0.100 in. over	5.000 in.			PCE273.1035
	Intake	1.600 in.	Stock	4.900 in.	8.000mm (0.314 in.)	0.160 in.	PCE273.1031
		2.165 in.	Stock	4.900 in.	8.000mm (0.314 in.)	0.160 in.	PCE273.1032
		2.200 in.					PCE273.1033
Holden 253 304 308	Exhaust	1.600 in.	Stock	5.335 in.	11/32 in. (0.344 in.)	0.250 in.	PCE273.1009
	Intake	2.020 in.	Stock	5.335 in.	11/32 in. (0.344 in.)	0.250 in.	PCE273.1010
Ford 302 351C Cleveland 460	Exhaust	1.710 in.	Stock	5.067 in.	11/32 in. (0.344 in.)	0.250 in.	PCE273.1037
			0.100 in. over	5.167 in.			PCE273.1043
	Intake	2.250 in.	Stock	5.244 in.	11/32 in. (0.344 in.)	0.280 in.	PCE273.1041
			0.100 in. over	5.344 in.			PCE273.1045
Ford 302 351W Windsor	Exhaust	2.190 in.	Stock	5.244 in.	11/32 in. (0.344 in.)	0.250 in.	PCE273.1039
			Stock	4.911 in.	11/32 in. (0.344 in.)	0.250 in.	PCE273.1048
	Intake	1.500 in.	Stock	4.911 in.	11/32 in. (0.344 in.)	0.250 in.	PCE273.1029
		1.600 in.				PCE273.1047	
Ford 429 460	Exhaust	1.940 in.	Stock	4.911 in.	11/32 in. (0.344 in.)	0.250 in.	PCE273.1047
			2.020 in.				PCE273.1030
	Intake	1.760 in.	Stock	5.067 in.	11/32 in. (0.344 in.)	0.340 in.	PCE273.1051
			0.100 in. over	5.167 in.			PCE273.1053
		2.190 in.	Stock	5.244 in.	11/32 in. (0.344 in.)	0.250 in.	PCE273.1055
Mopar Chrysler 318 360	Exhaust	2.250 in.	Stock	5.244 in.	11/32 in. (0.344 in.)	0.280 in.	PCE273.1059
			0.100 in. over	5.344 in.			PCE273.1061
	Intake	1.600 in.	0.050 in. over	5.011 in.	11/32 in. (0.344 in.)	0.250 in.	PCE273.1050
Chrysler BB 440	Exhaust	2.020 in.	0.050 in. over	5.011 in.	11/32 in. (0.344 in.)	0.250 in.	PCE273.1049
	Intake	1.810 in.	Stock	4.951 in.	11/32 in. (0.344 in.)	0.250 in.	PCE273.1067
Oldsmobile 400 425 455	Exhaust	1.860 in.	0.100 in. over	5.000 in.	11/32 in. (0.344 in.)	0.250 in.	PCE273.1068
			0.100 in. over	5.000 in.	11/32 in. (0.344 in.)	0.250 in.	PCE273.1069
	Intake	2.150 in.	0.100 in. over	5.000 in.	11/32 in. (0.344 in.)	0.250 in.	PCE273.1069
Oldsmobile 400 425 455	Exhaust	1.680 in.	Stock	4.713 in.	11/32 in. (0.344 in.)	0.250 in.	PCE273.1064
	Intake	2.072 in.	Stock	4.713 in.	11/32 in. (0.344 in.)	0.250 in.	PCE273.1063

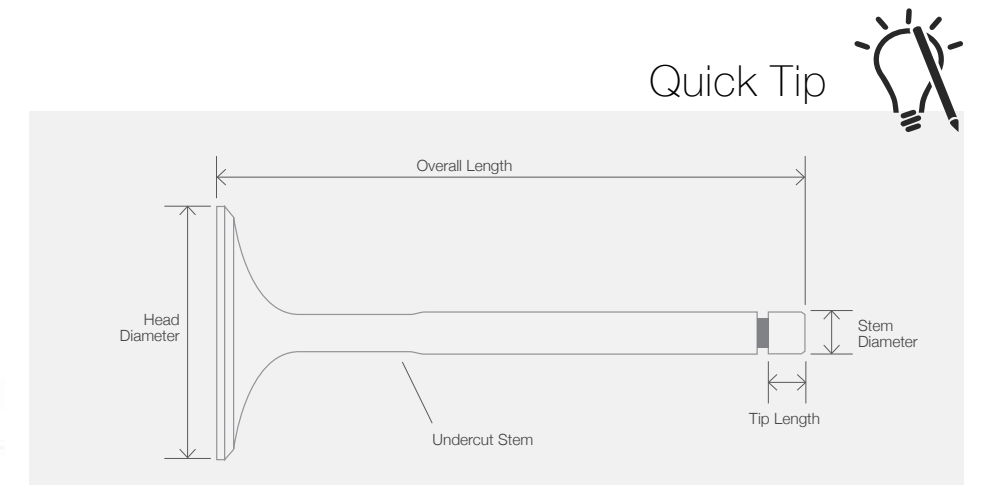

Valvetrain

Valve Springs

Speedmaster™ valve springs are made from a proprietary blend of alloys and tested under rigorous conditions to ensure that they perform at the highest level. They are CNC-coiled from high tensile-strength and extra-durable chrome-silicon steel and are double shot-peened beyond Aerospace Material Specification reliability standards. Whether you use them in your street or race machine, Speedmaster™ springs are built to perform and will help get the most out of your motor. These performance valve springs from Speedmaster™ are available for a variety of applications. Proper valve springs are essential to valvetrain performance, when matched with the right cam.

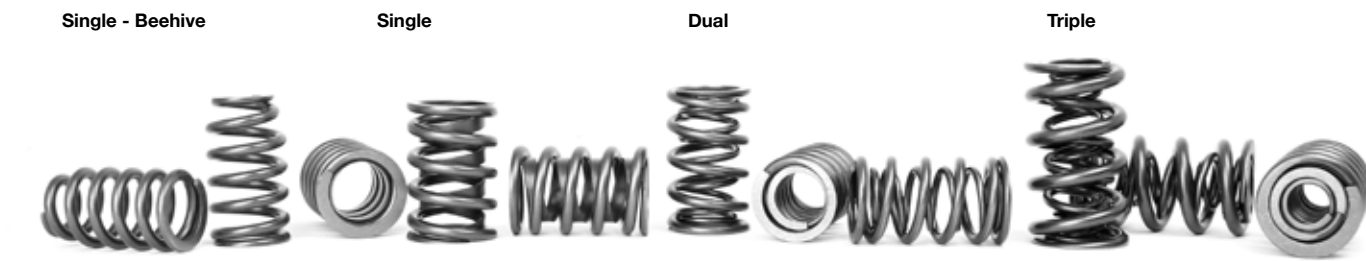

Number of Springs Per Valve	Outside Diameter of Outer Spring (in)	Installed Pressure	Suggested Open Pressure	Valve Spring Style	Damper Spring Included	Coil Bind Height (in)	SKU
Single	1.250 in.	125 lbs. @ 1.750 in.	335 lbs. @ .500 in. Lift	Standard	No	1.080 in.	PCE272.1006
	1.270 in.	150 lbs. @ 1.800 in.	260 lbs. @ .500 in. Lift	Beehive	No	1.240 in.	PCE272.1001
	1.450 in.	130 lbs. @ 1.785 in.	318 lbs. @ .500 in. Lift	Standard	No	1.150 in.	PCE272.1018
	1.450 in.	125 lbs. @ 1.900 in.	325 lbs. @ .600 in. Lift	Standard	Yes	1.150 in.	PCE272.1003
	1.550 in.	135 lbs. @ 1.900 in.	280 lbs. @ .500 in. Lift	Standard	Yes	1.125 in.	PCE272.1013
Dual	1.290 in.	140 lbs. @ 1.800 in.	270 lbs. @ .500 in. Lift	Standard	No	1.180 in.	PCE272.1002
	1.300 in.	150 lbs. @ 1.800 in.	385 lbs. @ .600 in. Lift	Standard	No	1.050 in.	PCE272.1016
	1.450 in.	130 lbs. @ 1.800 in.	335 lbs. @ .600 in. Lift	Standard	No	1.060 in.	PCE272.1007
	1.450 in.	145 lbs. @ 1.900 in.	420 lbs. @ .600 in. Lift	Standard	Yes	1.150 in.	PCE272.1004
	1.500 in.	200 lbs. @ 1.800 in.	450 lbs. @ .500 in. Lift	Standard	No	1.175 in.	PCE272.1005
	1.500 in.	110 lbs. @ 1.900 in.	390 lbs. @ .700 in. Lift	Standard	No	1.175 in.	PCE272.1017
	1.550 in.	150 lbs. @ 1.900 in.	390 lbs. @ .600 in. Lift	Standard	No	1.125 in.	PCE272.1009
Triple	1.550 in.	250 lbs. @ 2.050 in.	725 lbs. @ .800 in. Lift	Standard	No	1.175 in.	PCE272.1010
	1.560 in.	275 lbs. @ 2.100 in.	850 lbs. @ .800 in. Lift	Standard	Yes	1.175 in.	PCE272.1011
	1.560 in.	245 lbs. @ 2.000 in.	600 lbs. @ .700 in. Lift	Standard	No	1.200 in.	PCE272.1015
	1.635 in.	300 lbs. @ 2.050 in.	625 lbs. @ .650 in. Lift	Standard	No	1.325 in.	PCE272.1014

Valve Locks

Speedmaster™ valve locks are designed for stock or performance engines using 7 or 10 degree valve locks. They are manufactured from machined Chromoly steel and offer excellent valve spring location. Whether you're rebuilding a stock engine or changing to valve springs that have more seat pressure, these Speedmaster™ valve locks will provide the reliability that you've been looking for.

Lock Style	Valve Stem Diameter	Lock Groove Quantity	Install Height	SKU
7 degree	11/32 in. (0.344 in.)	1-groove	Standard 0.00 in.	PCE269.1001
			-0.030 in.	PCE269.1005
			-0.040 in.	PCE269.1006
10 degree	11/32 in. (0.344 in.)	1-groove	Standard 0.00 in.	PCE269.1002
			-0.030 in.	PCE269.1003
			-0.040 in.	PCE269.1007
			-0.060 in.	PCE269.1004



Valve Spring Retainers

Speedmaster™ spring retainers are made from hardened 4140 chromoly steel for great performance characteristics and reliability. On top of that, they're black-oxide coated for corrosion protection and looking.



Lock Style	Springs Per Valve	Valve Spring Style	OD of Outer Spring	OD of Middle Spring	ID of Inner Spring	SKU
7 degree	Single	Standard	1.250 in.	0.870 in.	0.650 in.	PCE270.1004
			1.375 in.	1.060 in.	0.695 in.	PCE270.1014
			1.400 in.	1.047 in.	0.690 in.	PCE270.1007
			1.500 in.	1.060 in.	0.690 in.	PCE270.1005
			1.250 in.	0.870 in.	0.735 in.	PCE270.1003
10 degree	Single	Standard	1.500 in.	1.150 in.	0.870 in.	PCE270.1008
			1.400 in.	1.060 in.	0.690 in.	PCE270.1006
			1.400 in.	1.095 in.	0.710 in.	PCE270.1010
			1.500 in.	1.120 in.	0.830 in.	PCE270.1013
			1.500 in.	1.125 in.	0.745 in.	PCE270.1012
			1.150 in.	0.870 in.	0.870 in.	PCE270.1009
			1.180 in.	0.690 in.	0.690 in.	PCE270.1011
8mm	Single	Beehive	0.935 in.	0.635 in.	-	PCE270.1002
			1.160 in.	0.950 in.	0.675 in.	PCE270.1001

Valve Spring Shims

Speedmaster™ valve spring shims are critical for setting up proper valve spring height and pressures. These high-quality, heat-treated valve spring shims are designed to handle the immense pressures of today's racing valve springs.



Outside Diameter (in)	Thickness (in)	SKU
1.570 in.	0.030 in.	PCE271.1002
	0.040 in.	PCE271.1003
	0.050 in.	PCE271.1004
	0.060 in.	PCE271.1005
	0.080 in.	PCE271.1006
	0.100 in.	PCE271.1007
	0.150 in.	PCE271.1008

Valve Stem Seals

Valve stem seals control the lubrication of the valve stem as it slides in the valve guide. Too little oil causes stem and guide wear. Too much oil increases oil consumption and can cause a buildup of carbon, leading to valve seat damage and early valve grind. Speedmaster™ valve seals are positive-stop seals made from high-temperature Viton® material for a long-lasting seal.



Valve Stem Diameter	Valve Guide Diameter	Outside Diameter	Notes	SKU
0.344 in.	0.500 in.	0.685 in.	-	PCE354.1001
0.344 in.	0.530 in.	0.685 in.	-	PCE354.1002
8mm	0.500 in.	0.610 in.	GM LS1 0.500 in. Long Single/Dual Springs	PCE354.1003
8mm	0.500 in.	1.190 in.	GM LS1 0.865 in. Long Single Springs	PCE354.1004
0.344 in.	0.530 in.	0.670 in.	0.670 in. Long	PCE354.1005

Valve Spring Locators

Speedmaster™ valve spring cups and locators protect your expensive aluminum heads from being galled by your high-pressure valve springs. They're quality-machined to different thicknesses from heat-treated steel with a corrosion-resistant black oxide finish. Speedmaster™ valve spring cups and locators are available in inside diameter (spring locator) or outside diameter (spring cup) styles.



Locating Shoulder Type	Outside Diameter (in)	Thickness (in)	SKU
Inside	1.550 in.	0.060 in.	PCE470.1001
	1.263 in.	0.060 in.	PCE470.1002
	1.560 in.	0.040 in.	PCE470.1003
Outside	1.370 in.	0.040 in.	PCE470.1004
	1.640 in.	0.040 in.	PCE470.1005

Drivetrain Components

Lash Caps

In today's higher rpm engines, the tip of the valve stem is subjected to a tremendous pounding. The best solution to this problem is Speedmaster™ lash caps. These hardened lash caps are precision-machined and ground perfectly flat, to maintain accurate valvetrain adjustment.

Valve Stem Diameter	Lash Cap Thickness (in)	Lash Cap Material	SKU
11/32 in. (0.344 in.)	0.080 in.	Steel	PCE252.1001



Guideplates

You need guideplates to keep your pushrods from deflecting under high-rpm conditions. That's just what our Speedmaster™ guideplate sets do, they are made from 5140 Chromoly steel, nitrided and black oxide coated for corrosion and wear resistance.



Application	Guideplate Pushrod Size	Guideplate Style	Stud Size	SKU
Chevrolet SBC 350	5/16 in.	Raised - 1 Piece	7/16 in.	PCE251.1007
		Flat - 1 Piece		PCE251.1003
		Flat - 1 Piece		PCE251.1004
		Flat - 2 Piece Adj		PCE251.1005
	3/8 in.	Raised - 1 Piece	7/16 in.	PCE251.1006
		Flat - 1 Piece		PCE251.1002
Chevrolet BBC 454	3/8 in.	Flat - 1 Piece	7/16 in.	PCE251.1010
		Flat - 2 Piece Adj		PCE251.1023
	7/16 in.	Raised - 1 Piece	7/16 in.	PCE251.1011
GM LS1	3/8 in.	Raised - 1 Piece	-	PCE251.1008
	5/16 in.		PCE251.1009	
Holden 253 304 308	5/16 in.	Flat - 1 Piece	7/16 in.	PCE251.1020
			5/16 in.	PCE251.1021
Holden Inline 6 202	5/16 in.	Flat - 1 Piece	7/16 in.	PCE251.1013
		Flat - 2 Piece Adj		PCE251.1014
Ford SB 289 302 351 Windsor	3/8 in.	Flat - 1 Piece	7/16 in.	PCE251.1022
		Flat - 2 Piece Adj		PCE251.1012
	5/16 in.	Flat - 1 Piece	5/16 in.	PCE251.1017
		Raised - 1 Piece		7/16 in.
Ford 302 351C Cleveland	3/8 in.	Raised - 1 Piece	7/16 in.	PCE251.1015
	5/16 in.	Raised - 1 Piece	7/16 in.	PCE251.1019
Ford 429 460	3/8 in.	Raised - 1 Piece	7/16 in.	PCE251.1018
	3/8 in.			PCE251.1018
Oldsmobile 350 400 403 425 455	3/8 in.	Flat - 1 Piece	7/16 in.	PCE251.1001

Cylinder Head Components

Valve Guides

Speedmaster™ valve guides are constructed from high-quality bronze for durability and wear, and built to exacting tolerances, they replace your existing worn or damaged valve guides. These guides are offered in a variety of diameters to suit your application.

PCE282.xxxx



Valve Seats

Valve seats are critical components in the life and performance of your valves. Speedmaster™ valve seats are crafted from strong ductile iron for exhaust and intake locations. When you need to service your heads, choose those made in the Speedmaster™ replacement valve seats.

PCE283.xxxx



Application	Intake	Exhaust
Chevrolet SBC 350 Ford SB 289 302 351 Windsor	PCE283.1002	PCE283.1001
Chevrolet BBC 454	PCE283.1004	PCE283.1003
Ford 429 460	PCE283.1006	PCE283.1005
Mopar Chrysler BB 383 440	PCE283.1008	PCE283.1007

Cylinder Head Bushing Kits

Speedmaster™ cylinder head bolt bushings are perfect when you need to make that big open hole fit the smaller bolt size in the block. They take the place of your head bolt washers and are hardened and chamfered.



Application	Outside Diameter	Inside Diameter	SKU
Ford SB 289 302 351 Windsor	0.500 in.	0.438 in.	PCE277.1001

Cylinder Head Fasteners

Speedmaster™ cylinder head fasteners are made from aircraft quality 8740 high tensile strength chromoly steel with a black oxide finish for added durability. They are heat-treated prior to thread rolling and machining and are rated at a whopping 190,000 psi.

Application	Fastener Style	Head Style	Notes	SKU
Chevrolet SBC 350	Bolt	12-point	-	PCE279.1002
		Hex	1/4" Longer	PCE279.1003
	Stud	12-point	-	PCE279.1026
Chevrolet BBC 454	Bolt	12-point	-	PCE279.1001
			8 Long Bolts	PCE279.1007
	Stud	12-point	8 Long Studs	PCE279.1008
			6.100 in.	PCE279.1005
GM LSX 1997-2002	Stud	12-point	-	PCE279.1006
GM LSX 2002-2006	Stud	12-point	-	PCE279.1023
Holden 186 202	Stud	12-point	-	PCE279.1022
Holden 253 304 308	Stud	12-point	-	PCE279.1019
			1/2 in.	PCE279.1020
Ford 250	Stud	12-point	-	PCE279.1009
Ford SB 289 302 Windsor	Bolt	12-point	-	PCE279.1011
	Stud	12-point	-	PCE279.1010
Ford 351W Windsor	Stud	12-point	-	PCE279.1012
Ford 302 351C Cleveland	Stud	12-point	-	PCE279.1013
			3V Heads	PCE279.1014
Ford 429 460	Stud	12-point	-	PCE279.1015
Chrysler 260	Stud	12-point	-	PCE279.1016
Mopar Chrysler BB 383 440	Stud	12-point	-	PCE279.1018
Mopar Chrysler SB 318 340 360	Stud	12-point	-	PCE279.1017
Fiat Lancia Delta 4cyl 1.6L 1600 Turbo	Stud	Hex	-	PCE279.1025



Pushrods, Assembled

Prior to extensive research, it was thought that the pushrod only had to be strong enough not to fail, bend or burn up at the ends. But engineers have learned that the frequency of the pushrod must match that of all the rest of the parts in the valve train, as well as the rpm at which the engine will be run. As cam profiles get more aggressive and valve spring pressures increase, the importance of selecting the right pushrods has never been more critical. Speedmaster™ carries a wide selection of precision pushrods to handle any application from stock replacement to hardcore race.



CH-Steel (PRO)

Get all of the performance that your engine can produce with these durable pushrods designed especially for high-lift cams. Speedmaster™ PRO pushrods are available in both 5/16 in. and 3/8 in. diameters. They feature .080 in. wall thickness and are formed from 4130 chromoly steel. These one-piece Speedmaster™ pushrods are heat-treated for use with guideplates. Plus, the oil holes are drilled and chamfered to .093 in. to prevent stress fractures and cracks.

Material: Chromoly Hardened Steel
Heat-Treated: Yes
Tip Attachment: Formed
One-Piece: Yes
For Use with Guideplates: Yes

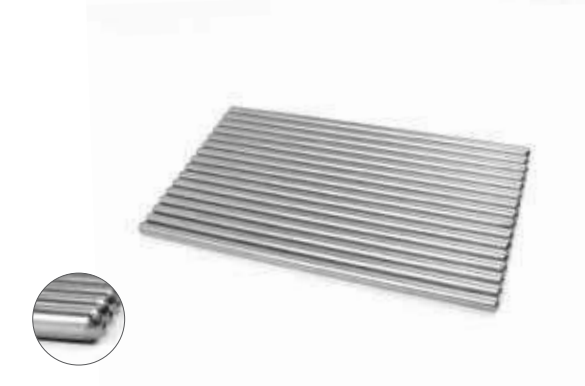

H-Steel

These Speedmaster™ pushrods are a great performance buy. Speedmaster™ pushrods feature heat-treated tips for strength and durability and are ideal for any stock rebuild or mildly modified performance buildup.

Material: Hardened Steel
Heat-Treated: Yes
Tip Attachment: Formed
One-Piece: No
For Use with Guideplates: Yes



Welded

These Speedmaster™ pushrods are one of the best performance bargains you can get. The pushrods feature welded tips (not pressed), so they won't break off, and are heat-treated for durability. They're ideal for any stock or mildly modified performance buildup.

Material: Hardened Steel
Heat-Treated: Yes
Tip Attachment: Welded
One-Piece: No
For Use with Guideplates: Yes



OEM

Speedmaster™ OEM replacement pushrods are perfect for stock rebuild or mild performance applications where open spring pressures do not exceed 300 lbs. They are manufactured from steel tubing and work well with stock or aftermarket rocker arms. When you're replacing your valvetrain components, try these Speedmaster™ OEM replacement pushrods to keep your engine running smoothly.

Material: Steel
Heat-Treated: No
Tip Attachment: Press fit
One-Piece: No
For Use with Guideplates: No

CH-Steel (PRO)

Pushrod Tube Diameter	Overall Length (in)	SKU
5/16 in.	6.100 in.	PCE254.1006
	6.270 in.	PCE254.1007
	6.300 in.	PCE254.1023
	6.700 in.	PCE254.1009
	6.770 in.	PCE254.1010
	7.170 in.	PCE254.1011
	7.200 in.	PCE254.1028
	7.220 in.	PCE254.1012
	7.300 in.	PCE254.1027
	7.400 in.	PCE254.1018
	7.450 in.	PCE254.1021
	7.800 in.	PCE254.1001
	7.803 in.	PCE254.1003
	7.815 in.	PCE254.1076 (**)
	7.850 in.	PCE254.1025
7.900 in.	PCE254.1002	
7.950 in.	PCE254.1013	
8.000 in.	PCE254.1014	
8.150 in.	PCE254.1015	
8.400 in.	PCE254.1070 (**)	
8.400 in.	PCE254.1057	
8.500 in.	PCE254.1016	
8.550 in.	PCE254.1004	
8.670 in.	PCE254.1017	
8.700 in.	PCE254.1005	
8.800 in.	PCE254.1055	
8.900 in.	PCE254.1019	
9.000 in.	PCE254.1020	
3/8 in.	7.800 in.	PCE254.1053
	7.900 in.	PCE254.1034
	8.280 in.	PCE254.1035
	8.400 in.	PCE254.1038
	8.450 in.	PCE254.1050
	8.500 in.	PCE254.1039
	8.550 in.	PCE254.1040
	8.650 in.	PCE254.1051
	8.700 in.	PCE254.1041
	8.750 in.	PCE254.1046
	8.750 in.	PCE254.1047
	8.800 in.	PCE254.1042
	9.250 in.	PCE254.1036
	9.350 in.	PCE254.1037
	9.450 in.	PCE254.1043
9.500 in.	PCE254.1044	
9.550 in.	PCE254.1045	

(**) = 210 degree radius on both end.

H-Steel

Pushrod Tube Diameter	Overall Length (in)	SKU
5/16 in.	7.800 in.	PCE254.1058
	7.900 in.	PCE254.1059
	8.400 in.	PCE254.1060
	8.550 in.	PCE254.1061
	8.700 in.	PCE254.1062

Welded

Pushrod Tube Diameter	Overall Length (in)	SKU
5/16 in.	6.800 in.	PCE254.1071
	6.815 in.	PCE254.1072
	6.876 in.	PCE254.1073
	6.900 in.	PCE254.1074
	6.915 in.	PCE254.1075
	8.000 in.	PCE254.1077
	8.165 in.	PCE254.1078
	8.309 in.	PCE254.1090
	8.500 in.	PCE254.1079
	8.560 in.	PCE254.1080
	8.600 in.	PCE254.1081
	8.630 in.	PCE254.1082
	8.690 in.	PCE254.1083
	8.746 in.	PCE254.1084
	8.900 in.	PCE254.1085
8.920 in.	PCE254.1086	
9.140 in.	PCE254.1087	
9.200 in.	PCE254.1088	
9.620 in.	PCE254.1089	

OEM

Pushrod Tube Diameter	Overall Length (in)	SKU
5/16 in.	7.800 in.	PCE254.1063
	7.900 in.	PCE254.1064
	8.000 in.	PCE254.1065
	8.400 in.	PCE254.1066
	8.500 in.	PCE254.1067
	8.700 in.	PCE254.1068
	8.900 in.	PCE254.1069

Rocker Arms

Smooth Valvetrain

Get smooth valvetrain operation, stable timing, and increased horsepower with Speedmaster™ rocker arms! Shop a huge selection of stud-, shaft-, and pedestal-mount rockers. Reduce engine weight with durable, lightweight extruded aluminum rockers. Or get superior severe-duty, high-rpm performance with forged steel rocker arms. Speedmaster™ rocker arms will ensure maximum performance from your entire valvetrain!



Quick Tip

Rocker Arm Ratio - The Math

The ratio of a rocker arm is determined by the distance between the centerline of the pivot point to the centerline of the roller tip (or area of contact with the valve stem), divided by the centerline of the pushrod to the centerline of the pivot point (X). Most aftermarket roller rockers have the ratio stamped on them. See Diagram.

To determine the change in lift when changing rocker arm ratios, divide the lift of the cam by the original rocker ratio (which gives you the lobe lift), then multiply this number by the new rocker ratio. For example, a popular small block chevy cam has .468 lift at the valve. Divide this number by the stock rocker ratio of 1.5 to get the lobe lift of .312. Multiply .312 by the new rocker ratio 1.6, to get the new lift of .499.

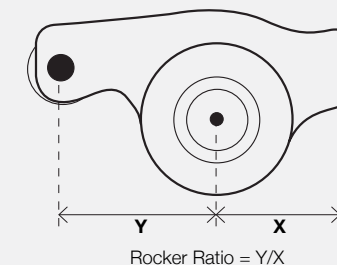

Stud Mount



Full Roller | Aluminum

Superstreet Series

Speedmaster™ Superstreet Series Aluminum Roller Rockers are extruded from 6061 T6 Aluminum. The larger needle bearing fulcrum can withstand valve spring loads up to 320lbs. Ideally suited for use with flat tappet roller cams.

320LBS

Outlaw Series

Speedmaster™ Aluminum Outlaw Series Roller Rockers are extruded from 6061 T6 Aluminum. The larger needle bearing fulcrum can withstand valve spring loads up to 360lbs, while the extruded body has a tensile strength over 60,000 PSI. Ideally suited for use with Solid / Mechanical flat tappet and Hydraulic Roller Cams.

360LBS

Sportsman Pro Series

These rocker arms are used around the world by professional racers, engine builders and hot rod enthusiasts, offering outstanding power and performance advantages for street, strip, and track applications. Made from high strength 6061-T6 aluminum extrusions, each piece is precision CNC machined and finished by hand to ensure that our customers receive the very best Speedmaster™ has to offer.

700LBS

Pedestal Mount



Aluminum

Stainless Steel

Outlaw Series

Speedmaster™ aluminum rocker arms are made from 6061-T6 aluminum. Each rocker body is relieved for extra valve spring clearance and anodized for added strength. CNC machined billet steel pedestals, alloy steel fasteners, and needle roller bearings.

360LBS

Sportsman Series

Speedmaster™ Sportsman Series stainless steel pedestal mount rollers are manufactured from heat-treated stainless steel and alloy steel tip rollers. CNC machined billet steel pedestals, alloy steel fasteners, and needle roller bearings. They feature greater strength and durability, capable of withstanding valve spring load up to 450lbs.

450LBS

Full Roller | Stainless Steel



Sportsman Series

Speedmaster™ Stainless steel rollers are manufactured from heat-treated stainless steel and alloy steel tip rollers. Speedmaster roller rockers are available in various ratios, so you are good to go. They feature greater strength and durability, capable of withstanding valve spring load up to 450lbs.

450LBS

Sportsman Pro Series

The Sportsman Pro series rollers are manufactured from heat-treated stainless steel and alloy steel tip rollers. They feature greater strength and durability, capable of withstanding valve spring load up to 700lbs.

700LBS

Roller Tip | Chromoly Steel



Street Series

Speedmaster™ 4340 chromoly steel roller tip rockers have a long slot and are for high lift cams to stand valve spring pressure up to 300lbs. A self-locking nut and powdered metal pivot ball are included with rocker. One way to increase power is to increase lift. That's what makes Speedmaster™ steel roller tip rocker arms so popular. They're one of the highest lift rockers you can get outside of racing. And, along with the lift, you also get a ball pivot roller tip to prevent valve stem and guide wear.

300LBS

Shaft Mount



Aluminum

Stainless Steel

Outlaw Series

Speedmaster™ Outlaw Series aluminum shaft mount rocker system includes steel shafts with pedestals. All rockers feature large needle bearings and roller tips. They not only unleash horsepower, but they also lengthen valvetrain component life and reduce wear and tear on valve stem tips. These rockers are precision-machined to ensure consistency and ratio accuracy.

360LBS

Sportsman Pro Series

Speedmaster™ Sportsman Pro Series Aluminum shaft mount Rocker Arms are used around the world by professional racers, engine builders and hot rod enthusiasts, offering outstanding power and performance advantages for street, strip, and track applications. Each piece is precision CNC machined and finished by hand to ensure that our customers receive the very best Speedmaster™ has to offer.

700LBS

Sportsman Series

Speedmaster™ Sportsman Series stainless steel shaft mount rollers are manufactured from heat-treated stainless steel and alloy steel tip rollers. Speedmaster roller rockers are available in various ratios, so you are good to go. They feature greater strength and durability, capable of withstanding valve spring load up to 450lbs.

450LBS



Next

Stud Mount | Aluminum

Application	Mounting Style	Ratio	Rocker Arm Style	Stud Size	Rocker Arm Material	Self-Aligning	Rocker Arm Finish	Notes	SKU
Chevrolet SBC 350	Stud	1.5	Full roller	3/8 in.	Aluminum	No	Red anodized		PCE261.1001
						No	Black anodized	Superstreet	PCE261.1160
						No	Gold anodized		PCE261.1002
						No	Gold anodized		PCE261.1150
						No	Clear anodized		PCE261.1151
						No	Gold anodized	Outlaw	PCE261.1003
				Yes	Gold anodized		PCE261.1039		
				No	Blue anodized	Sportsman Pro	PCE261.1147		
				No	Red anodized		PCE261.1004		
				No	Black anodized	Superstreet	PCE261.1161		
				No	Gold anodized		PCE261.1005		
				No	Gold anodized		PCE261.1152		
		7/16 in.	Aluminum	No	Clear anodized		PCE261.1153		
				No	Gold anodized	Outlaw	PCE261.1006		
				Yes	Gold anodized		PCE261.1040		
				No	Blue anodized	Sportsman Pro	PCE261.1170		
				No	Blue anodized		PCE261.1143		
				No	Red anodized		PCE261.1007		
		3/8 in.	Aluminum	1.6	Full roller	No	Black anodized	Superstreet	PCE261.1162
						No	Gold anodized		PCE261.1008
						No	Gold anodized		PCE261.1154
						No	Clear anodized	Outlaw	PCE261.1155
						No	Gold anodized		PCE261.1009
						No	Blue anodized	Sportsman Pro	PCE261.1142
7/16 in.	Aluminum			No	Red anodized		PCE261.1010		
				No	Black anodized	Superstreet	PCE261.1163		
				No	Gold anodized		PCE261.1011		
				No	Gold anodized		PCE261.1156		
				No	Clear anodized	Outlaw	PCE261.1157		
				No	Gold anodized		PCE261.1012		
7/16 in.	Aluminum	1.7	Full roller	No	Blue anodized	Sportsman Pro	PCE261.1166		
				No	Blue anodized		PCE261.1144		
				No	Red anodized		PCE261.1013		
				No	Black anodized	Superstreet	PCE261.1164		
				No	Gold anodized		PCE261.1014		
				No	Gold anodized		PCE261.1158		
Chevrolet BBC 454	Stud	1.7	Full roller	7/16 in.	Aluminum	No	Clear anodized	Outlaw	PCE261.1159
						No	Gold anodized		PCE261.1015
						No	Blue anodized	Sportsman Pro	PCE261.1145
						No	Blue anodized		PCE261.1145

Stud Mount | Aluminum

Application	Mounting Style	Ratio	Rocker Arm Style	Stud Size	Rocker Arm Material	Self-Aligning	Rocker Arm Finish	Notes	SKU			
Ford SB 289 302 351 Windsor	Stud	1.6	Full roller	3/8 in.	Aluminum	No	Red anodized	Superstreet	PCE261.1016			
						No	Gold anodized		PCE261.1017			
						No	Gold anodized	Outlaw	PCE261.1018			
				No		Blue anodized	Sportsman Pro	PCE261.1148				
				No		Red anodized	Superstreet	PCE261.1019				
				No		Gold anodized	Outlaw	PCE261.1021				
		7/16 in.	No	Gold anodized	Outlaw	PCE261.1022						
			No	Blue anodized	Sportsman Pro	PCE261.1167						
			1.73	Full roller	7/16 in.	Aluminum	No	Red anodized	Superstreet	PCE261.1020		
			Ford 302 351C Cleveland	Stud	1.73	Full roller	7/16 in.	Aluminum	No	Red anodized	Superstreet	PCE261.1023
									No	Gold anodized		PCE261.1024
									No	Gold anodized	Outlaw	PCE261.1025
No	Blue anodized	Sportsman Pro							PCE261.1146			
Ford 250	Stud	1.73	Full roller	7/16 in.	Aluminum	No	Red anodized	Superstreet	PCE261.1120			
Holden 253 304 308	Stud	1.65	Full roller	3/8 in.	Aluminum	No	Red anodized	Superstreet	PCE261.1026			
						No	Gold anodized		PCE261.1027			
				7/16 in.		No	Red anodized	Superstreet	PCE261.1028			
						No	Gold anodized		PCE261.1029			
Holden Inline 6 202	Stud	1.6	Full roller	3/8 in. 7/16 in.	Aluminum	No	Red anodized	Superstreet	PCE261.1121 PCE261.1119			
Oldsmobile 330 350 400 425 455	Stud	1.65	Full roller	7/16 in.	Aluminum	No	Gold anodized	Superstreet	PCE261.1117			

More 

Stud Mount | Stainless Steel

Application	Mounting Style	Ratio	Rocker Arm Style	Stud Size	Rocker Arm Material	Self-Aligning	Rocker Arm Finish	Notes	SKU		
Chevrolet SBC 350	Stud	1.5	Full roller	3/8 in.	Stainless steel	Yes	Natural	Sportsman	PCE261.1065		
						No		Sportsman	PCE261.1061		
				Yes	Sportsman Pro	PCE261.1090					
				No	Sportsman	PCE261.1066					
		1.55	Full roller	3/8 in.	Stainless steel	No	Natural	Sportsman	PCE261.1062		
						No		Sportsman Pro	PCE261.1172		
				7/16 in.	Stainless steel	No	Natural	Sportsman Pro	PCE261.1169		
				Yes	Sportsman	PCE261.1069					
		1.6	Full roller	3/8 in.	Stainless steel	No	Natural	Sportsman	PCE261.1068		
						Yes		Sportsman	PCE261.1089		
				No	Sportsman Pro	PCE261.1168					
				Yes	Sportsman	PCE261.1071					
		1.65	Full roller	3/8 in.	Stainless steel	No	Natural	Sportsman	PCE261.1063		
						No		Sportsman Pro	PCE261.1171		
				7/16 in.	Stainless steel	No	Natural	Sportsman	PCE261.1067		
				Yes	Sportsman	PCE261.1072					
		Chevrolet BBC 454	Stud	1.7	Full roller	7/16 in.	Stainless steel	No	Natural	Sportsman	PCE261.1072
								No		Sportsman Pro	PCE261.1140
				1.73	Full roller	7/16 in.	Stainless steel	No	Natural	Sportsman	PCE261.1073
				1.8	Full roller	7/16 in.	Stainless steel	No	Natural	Sportsman	PCE261.1074
Ford SB 289 302 351 Windsor	Stud	1.6	Full roller	3/8 in.	Stainless steel	No	Natural	Sportsman	PCE261.1075		
						No		Sportsman Pro	PCE261.1135		
				Yes	Sportsman	PCE261.1077					
				No	Sportsman	PCE261.1076					
Ford 302 351C Cleveland	Stud	1.73	Full roller	7/16 in.	Stainless steel	Yes	Natural	Sportsman	PCE261.1080		
						No		Sportsman	PCE261.1078		
Ford 460	Stud	1.8	Full roller	7/16 in.	Stainless steel	No	Natural	Sportsman	PCE261.1079		
						No		Sportsman Pro	PCE261.1141		
Holden 253 304 308	Stud	1.65	Full roller	3/8 in.	Stainless steel	No	Natural	Sportsman	PCE261.1081		
				7/16 in.				Sportsman	PCE261.1082		

Roller Tip | Chromoly Steel

Application	Mounting Style	Ratio	Rocker Arm Style	Stud Size	Rocker Arm Material	Self-Aligning	Rocker Arm Finish	SKU
Chevrolet SBC 350	Stud	1.5	Roller tip	3/8 in.	Steel	No	Natural	PCE261.1042
				Yes		PCE261.1043		
				Yes		PCE261.1045		
		7/16 in.	Steel	No	Natural	PCE261.1044		
		1.6	Roller tip	3/8 in.	Steel	No	Natural	PCE261.1046
				Yes		PCE261.1047		
No	Natural			PCE261.1048				
Yes	Natural	PCE261.1049						
Chevrolet BBC 454	Stud	1.7	Roller tip	7/16 in.	Steel	Yes	Natural	PCE261.1051
						No		PCE261.1050
Ford SB 289 302 351 Windsor	Stud	1.6	Roller tip	3/8 in.	Steel	Yes	Natural	PCE261.1053
						No		PCE261.1052
		1.7	Roller tip	3/8 in.	Steel	Yes	Natural	PCE261.1055
Ford 302 351C Cleveland	Stud	1.73	Roller tip	7/16 in.	Steel	No	Natural	PCE261.1056
						Yes		PCE261.1057

Pedestal Mount | Aluminum

Application	Mounting Style	Ratio	Rocker Arm Style	Stud Size	Rocker Arm Material	Self-Aligning	Rocker Arm Finish	SKU
Ford SB 289 302 351 Windsor	Pedestal	1.6	Full roller	5/16 in.	Aluminum	No	Gold anodized	PCE261.1133
GM LSX	Pedestal	1.7	Full roller	-	Aluminum	No	Gold anodized	PCE261.1041
		1.8					Clear anodized	PCE261.1123
GM LS1 LS6	Pedestal	1.8	Full roller	-	Aluminum	No	Clear anodized	PCE261.1127
GM LS3 L92	Pedestal	1.7	Full roller	-	Aluminum	No	Clear anodized	PCE261.1126

Pedestal Mount | Stainless Steel

Application	Mounting Style	Ratio	Rocker Arm Style	Rocker Arm Material	Self-Aligning	Rocker Arm Finish	SKU
GM LSX	Pedestal	1.7	Full roller	Stainless steel	No	Natural	PCE261.1092
		Yes			PCE261.1118		
		1.8	Full roller	Stainless steel	No	Natural	PCE261.1091
		1.9			No		Natural



Shaft Mount | Aluminum

Application	Mounting Style	Ratio	Rocker Arm Style	Rocker Arm Material	Self-Aligning	Rocker Arm Finish	Notes	SKU
Chevrolet SBC 350	Shaft	1.5	Full roller	Aluminum	No	Gold anodized	Zero Offset	PCE261.1093
							Offset: 0.100 in. intake	PCE261.1094
							Offset: 0.160 in. intake	PCE261.1095
							Offset: 0.250 in. intake	PCE261.1096
							-	PCE261.1131
		1.6	Full roller	Aluminum	No	Gold anodized	Zero Offset	PCE261.1098
							Offset: 0.080 in. intake	PCE261.1175
							Offset: 0.100 in. intake	PCE261.1099
							Offset: 0.120 in. intake	PCE261.1176
							Offset: 0.140 in. intake	PCE261.1100
		1.6/1.5	Full roller	Aluminum	Yes	Clear anodized	Offset: 0.160 in. intake	PCE261.1101
							Offset: 0.180 in. intake	PCE261.1102
							Offset: 0.180 in. intake	PCE261.1177
							Offset: 0.200 in. intake	PCE261.1178
							Offset: 0.240 in. intake	PCE261.1103
1.6/1.5	Full roller	Aluminum	Yes	Natural	Offset: .450 in. intake, .180 in. exhaust	PCE261.1107		
					-	PCE261.1132		
					Sportsman Pro	PCE261.1139		
					-	PCE261.1060		
					-	PCE261.1104		
Chevrolet BBC 454	Shaft	1.7	Full roller	Aluminum	No	Gold anodized	-	PCE261.1128
							-	PCE261.1106
							-	PCE261.1129
Ford SB 289 302 351 Windsor	Shaft	1.6	Full roller	Aluminum	Yes	Natural	-	PCE261.1058
							-	PCE261.1059
							-	PCE261.1134
Ford FE 390 427 428	Shaft	1.76	Full roller	Aluminum	No	Gold anodized	w/ Bearings	PCE261.1149
							-	PCE261.1130
							-	PCE261.1105
GM LSX	Shaft	1.8	Full roller	Aluminum	No	Natural	Sportsman Pro	PCE261.1031
							-	PCE261.1032
							-	PCE261.1033
GM LS1 LS6	Shaft	1.7	Full roller	Aluminum	Yes	Natural	-	PCE261.1034
							-	PCE261.1036
							-	PCE261.1037
Holden 253 304 308	Shaft	1.6	Full roller	Aluminum	No	Gold anodized	-	PCE261.1174
							-	PCE261.1032
							-	PCE261.1033
Mopar Chrysler SB 318 340 360	Shaft	1.5	Full roller	Aluminum	No	Red anodized	-	PCE261.1036
							-	PCE261.1037
							-	PCE261.1174
Mopar Chrysler BB 383 440	Shaft	1.6	Full roller	Aluminum	No	Red anodized	Offset: 0.450 in. intake	PCE261.1036
							Offset: 0.610 in. intake	PCE261.1037
							Offset: 0.630 in. intake	PCE261.1174
Oldsmobile 330 350 400 425 455	Shaft	1.6	Full roller	Aluminum	No	Natural	-	PCE261.1116
							-	PCE261.1116

Shaft Mount | Stainless Steel

Application	Mounting Style	Ratio	Rocker Arm Style	Rocker Arm Material	Self-Aligning	Rocker Arm Finish	Notes	SKU
Chevrolet SBC 350	Shaft	1.5	Full roller	Stainless steel	No	Natural	-	PCE261.1108
		1.6	Full roller	Stainless steel	No	Natural	Zero Offset	PCE261.1109
		-	-	-	-	-	Offset: 0.100 in. intake	PCE261.1110
Chevrolet BBC 454	Shaft	1.7	Full roller	Stainless steel	Yes	Natural	-	PCE261.1115
Ford SB 289 302 351 Windsor	Shaft	1.6	Full roller	Stainless steel	No	Natural	-	PCE261.1111
		1.7	Full roller	Stainless steel	No	Natural	-	PCE261.1114
Ford FE 390 427 428	Shaft	1.76	Full roller	Stainless Steel	Yes	Natural	-	PCE261.1173
Holden 253 304 308	Shaft	1.6	Full roller	Stainless steel	-	Natural	-	PCE261.1112
Mopar Chrysler SB 318 340 360	Shaft	1.5	Full roller	Stainless steel	No	Natural	-	PCE261.1084
		1.6	Full roller	Stainless steel	No	Natural	-	PCE261.1085
Mopar Chrysler BB 383 440	Shaft	1.5	Full roller	Stainless steel	No	Natural	-	PCE261.1087
		1.6	Full roller	Stainless steel	No	Natural	-	PCE261.1088

Quick Tip



Checking Rocker Geometry

Rocker arm geometry in relation to the installation is critical. Having the proper valve train geometry is critical to the system being durable and providing the proper valve lift. The tip of the rocker should operate around the centreline of the valve stem when the rocker opens the valve. Locating the rocker properly is achieved by moving mounting points combining different length pushrods and valve stems or changing rockers.

The theoretical ratio is the distance from the point where the rocker tip touches the valve to the fulcrum centreline, divided by the distance from the centre of the pushrod cup or adjusting screw to the fulcrum centreline. Since valve trains have many components, deflection or production tolerances will usually affect the actual valve lift, therefore the theoretical ratio will usually be slightly higher than the rated ratio of the rocker. For this reason it is always a good idea to check the lift of each valve for your application to determine if the valve opening is the same on all the cylinders.

The roller tip should ideally contact the valve stem centre when the valve is at half lift. If it contacts the stem towards the outside of the head, the pushrod is too long or if the contact is toward the fulcrum, the pushrod is too short.



Most importantly the contact patch on the valve tip should be between 1.5mm and 2.0mm (.060"-.080") wide. Valve guide side loading is a result of excessive roller tip lateral movement and not simply the position of valve tip contact. As shown in the diagrams below, a narrow contact patch slightly off valve centre is preferred to a wide contact in the centre of the valve.

The easiest way to check roller/valve tip relationship is to apply a very light smear of "bearing blue" (Available from auto parts suppliers) to the tip of the valve, then carefully assemble the rocker/rockers to the cylinder head.

Once the valve has opened and closed, you can clearly see the "contact patch" of the roller. This contact patch should be as close as possible to the centre of the valve and as thin as possible to minimise the amount of side loading on the valve experienced under extreme operating conditions. Lash caps can sometimes be used instead of changing pushrods to alter rocker geometry. It is important to note when using rigid mount shaft type or pedestal type rockers, the mounting pedestal or spacer height may need to be altered to make geometry changes.

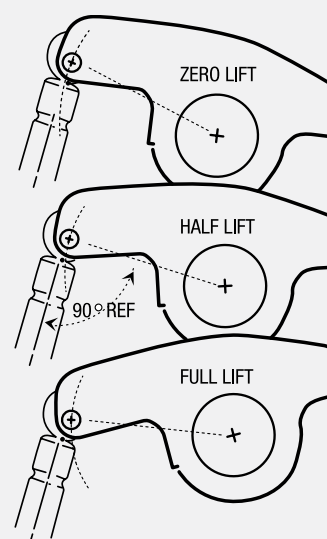
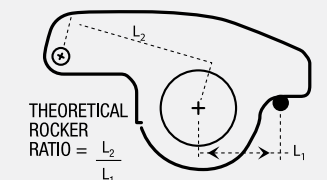

Read More Page 296

Valve Covers

Keep the Oil in and the Dirt out

Valve covers come in more flavors than ice cream. Speedmaster™ has a delicious selection of valve covers to suit your tastes, including a variety of sizes, styles, and applications. You'll find valve covers to fit everything from traditional Chevy 350 engines to modern LS1, LS3, and LSX motors. Choose a set of plain steel or aluminum valve covers; go old school with finned, ribbed, or ball-milled covers; or add some flash with chrome, polished, carbon fiber, or color-anodized finishes.

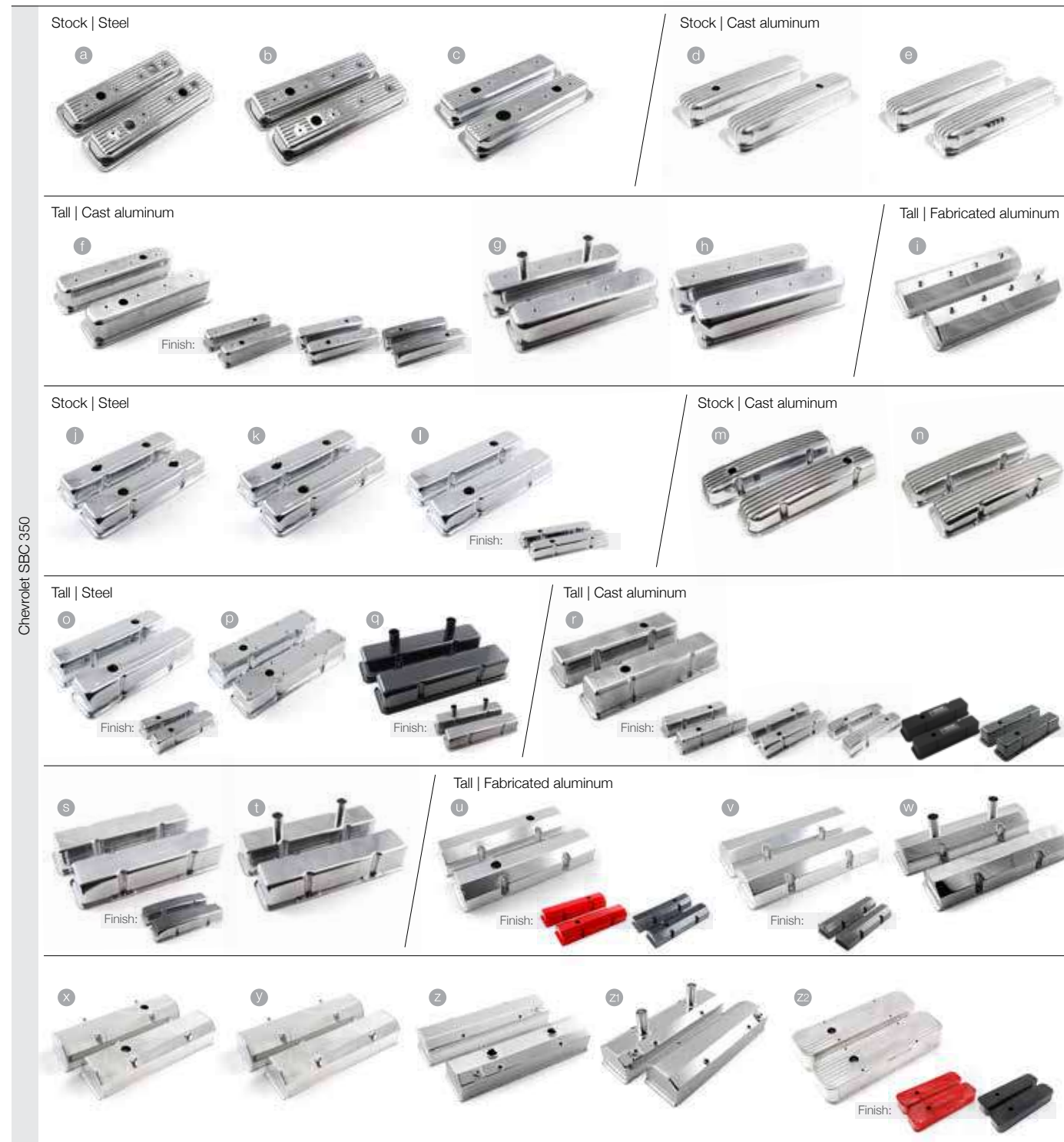

Chevrolet SBC 350



Chevrolet BBC 454

Chevrolet 173 2.8L V6

Chevrolet 229 3.8L V6

Chevrolet 262 4.3L V6

Chevrolet 217 L6

Chevrolet 194-292 L6

Chevrolet 235 L6

More

Valve Covers

Ford SB 289 302 351 Windsor	Stock Steel ba 	Stock Cast aluminum bb 	Tall Cast aluminum bc Finish:
	bd Finish:	Tall Fabricated aluminum be bf bg Finish:	
Ford 302 351 C Cleveland	Stock Steel bh 	Tall Cast aluminum bi Finish:	
	Tall Fabricated aluminum bj bk 		
Ford 429 460	Stock Steel bl 	Tall Cast aluminum bm Finish:	Tall Fabricated aluminum bn
	Ford 240 300 L6 bo 	Ford Fe 390 427 428 bp 	

GM LSX LS1 LS2 LS3 LS6 LS7	Fabricated aluminum ca cb cc cd 			
	VN Heads ce 	304 Heads cf 	308 Heads cg 	
Holden 253 304 308	ch 	Mopar Chrysler SB 318 340 360 Stock Steel ci 	Tall Fabricated aluminum cj ck 	
Mopar Chrysler 170 198 225	cl 	Tall Fabricated aluminum cm 	Oldsmobile 350 400 425 455 Stock Steel cn 	Tall Fabricated aluminum co
Mopar Chrysler BB 388 440	cp 	Pontiac 326 400 455 Tall Steel cp 	Tall Cast aluminum cq cr 	
Chrysler Hemi 426	cs 	ct 	Amc 304 360 390 401 cu 	Cadillac 368 425 500 cv



Valve Covers

Application	Valve Cover Mounting Style	Valve Cover Height	Ref.	Notes	Valve Cover Material	Valve Cover Finish	Valve Cover Top Style	Breather Hole	SKU		
Chevrolet SBC 350	Centerbolt	Short	a.	-	Steel	Chrome	Ball-milled	Yes	PCE314.1061		
			b.	-			Plain	Truck Hole	PCE314.1060		
			c.	Truck Only			Plain	Truck Hole	PCE314.1054		
			d.	-	Cast aluminum	Polished	Finned	Yes	PCE314.1009		
			e.	-			Plain	No	PCE314.1166		
		Tall	f.	-	Cast aluminum	Polished	Ball-milled	Yes	PCE314.1075		
				-			Flames	Yes	PCE314.1024		
				-			Flames	Yes	PCE314.1025		
				-	Cast aluminum	Polished	Finned	Yes	PCE314.1008		
			g.	-			Plain	Yes - Tube Tos	PCE314.1026		
			h.	-			Plain	No	PCE314.1022		
			i.	-	Fabricated aluminum	Polished	Clear anodized	Plain	No	PCE314.1137	
				-				Plain	Yes	PCE314.1149	
			Perimeter bolt	Short	j.	OEM Style	Steel	Chrome	Plain	Yes x4	PCE314.1052
					k.	-				Yes	PCE314.1057
		-			Steel	Chrome	Plain	Yes	PCE314.1003		
	l.	-					327 logo	Yes	PCE314.1038		
		-					350 logo	Yes	PCE314.1064		
		-		Cast aluminum	Polished	Finned	Yes	PCE314.1006			
	m.	-				Plain	No	PCE314.1164			
	Tall	n.		-	Steel	Chrome	Plain	Yes	PCE314.1002		
				-			327 logo	Yes	PCE314.1037		
				-			350 logo	Yes	PCE314.1067		
				-	Steel	Chrome	Plain	Yes	PCE314.1063		
				-			327 logo	Yes	PCE314.1067		
				-			350 logo	Yes	PCE314.1063		
				-	Steel	Chrome	Black	Yes	PCE314.1062		
		p.		-			Polished	Yes	PCE314.1014		
		q.	Circle Track	Steel	Natural	Plain	Yes - Tube Tos	PCE314.1015			
			-		Zinc	Plain	Yes - Tube Tos	PCE314.1016			
	-	Cast aluminum	Chrome	Plain	Yes	PCE314.1071					
	-		Polished			PCE314.1070					
	-		Polished			PCE314.1018					
	-	Cast aluminum	Carbon Fiber	Plain	Yes	PCE314.1187					
	-		Polished			PCE314.1073					
	-		Polished			PCE314.1019					
	-	Cast aluminum	Polished	Ball-milled	Yes	PCE314.1020					
	-		Polished			PCE314.1020					
	-		Black wrinkle			Procomp Electronics logo	Yes	PCE314.1072			
	-	Cast aluminum	Polished	Finned	Yes	PCE314.1005					
	-			Plain	No	PCE314.1017					
	-	Cast aluminum	Polished	Finned	No	PCE314.1007					
	-			Plain	Yes - Tube Tos	PCE314.1078					
	-	Circle Track	Cast aluminum	Polished	Plain	Yes - Tube Tos	PCE314.1021				

Application	Valve Cover Mounting Style	Valve Cover Height	Ref.	Notes	Valve Cover Material	Valve Cover Finish	Valve Cover Top Style	Breather Hole	SKU
Chevrolet SBC 350	Perimeter bolt	Tall	u.	-	Fabricated aluminum	Clear anodized	Plain	Yes	PCE314.1140
				-			Chrome	Yes	PCE314.1095
				-			Natural	Yes	PCE314.1094
				-	Fabricated aluminum	Polished	Plain	Yes	PCE314.1100
				-			Red powdercoated	Yes	PCE314.1096
			-	Fabricated aluminum	Carbon Fiber	Plain	Yes	PCE314.1183	
			-			Natural	No	PCE314.1102	
			-	Fabricated aluminum	Polished	Plain	No	PCE314.1101	
			-			Carbon Fiber	No	PCE314.1184	
			-	Fabricated aluminum	Natural	Plain	Yes - Tube Tos	PCE314.1103	
			-			Polished	Yes - Tube Tos	PCE314.1104	
			Long Bolt	Fabricated aluminum	Natural	Plain	Yes	PCE314.1097	
			Long Bolt		Polished	Plain	Yes	PCE314.1098	
			Long Bolt	Fabricated aluminum	Polished	Plain	No	PCE314.1099	
			Circle Track		Clear anodized	Plain	Yes	PCE314.1141	
		Circle Track	Fabricated aluminum	Clear anodized	Plain	Yes - Tube Tos	PCE314.1178		
		-		Red anodized			PCE314.1181		
		-	Fabricated aluminum	Black anodized	Speedmaster logo	Yes	PCE314.1157		
		-		Clear anodized			PCE314.1156		
		-		Polished			PCE314.1158		
		OEM Style					PCE314.1055		
		OEM Style - for Corvette and power brakes.	Steel	Chrome	Plain	Yes	PCE314.1056		
		-	Steel	Chrome	Plain	Yes	PCE314.1041		
		-			454 logo	Yes	PCE314.1066		
		-	Steel	Chrome	Plain	Yes	PCE314.1004		
		-			396 logo	Yes	PCE314.1040		
		-			454 logo	Yes	PCE314.1065		
		-		Chrome			PCE314.1080		
		-		Polished	Plain	Yes	PCE314.1079		
		-		Polished			PCE314.1028		
	-	Cast aluminum	Polished	Flames	Yes	PCE314.1082			
	-		Polished	Ball-milled	Yes	PCE314.1030			
	-	Cast aluminum	Polished	Ball-milled	Yes	PCE314.1081			
	-		Polished	Plain	Yes	PCE314.1029			
	-		Polished	Finned	Yes	PCE314.1010			
	-	Cast aluminum	Polished	Plain	No	PCE314.1027			
	-		Polished	Finned	No	PCE314.1165			
	-		Chrome			PCE314.1107			
	-		Natural			PCE314.1105			
	-	Fabricated aluminum	Polished	Plain	Yes	PCE314.1109			
	-		Clear anodized	Clear anodized			PCE314.1142		
	-		Clear anodized			PCE314.1106			
	-		Carbon Fiber			PCE314.1186			
	-		Natural		No	PCE314.1111			
	-	Fabricated aluminum	Natural	Plain	Yes - Tube Tos	PCE314.1112			
	-		Polished		Yes - Tube Tos	PCE314.1177			
	Long Bolt	Fabricated aluminum	Polished	Plain	Yes	PCE314.1110			
	Long Bolt		Black			PCE314.1173			
	Long Bolt	Fabricated aluminum	Orange Powdercoated			PCE314.1174			
	Long Bolt		Polished	Plain	No	PCE314.1160			

Continued 

Valve Covers

Application	Valve Cover Mounting Style	Valve Cover Height	Ref.	Notes	Valve Cover Material	Valve Cover Finish	Valve Cover Top Style	Breather Hole	SKU						
Chevrolet 173 2.8L V6	Perimeter bolt	Stock	am.	Trucks Only					PCE314.1050						
Chevrolet 229 3.8L V6	Perimeter bolt	Stock	an.	-					PCE314.1033						
Chevrolet 262 4.3L V6	Centerbolt	Stock	ao.	Trucks Only					PCE314.1053						
Chevrolet 217 L6 1942-53	Centerbolt	4.250 in.	ap.	-	Steel	Chrome	Plain	Yes	PCE314.1035						
Chevrolet 194 230 250 292 L6 1962-74	Perimeter bolt	Stock	aq.	-					PCE314.1039						
Chevrolet 235 L6 1954-62	Perimeter bolt	3.875 in.	ar.	-					PCE314.1034						
Ford SB 289 302 351 Windsor	Perimeter bolt	Stock	ba.	-	Steel	Chrome	Plain	Yes	PCE314.1042						
			bb.	-	Cast aluminum	Polished	Finned	Yes	PCE314.1013						
			bc.	-	Cast aluminum	Polished	Plain	Yes	PCE314.1032						
							Ball-milled	Yes	PCE314.1086						
							Flames	Yes	PCE314.1087						
							Black wrinkle Blue powdercoated	Yes	PCE314.1085						
			bd.	-	Cast aluminum	Polished	Procomp Electronics logo	Yes	PCE314.1084						
							Finned	Yes	PCE314.1167						
							Plain	No	PCE314.1031						
							Finned	No	PCE314.1168						
			be.	-	Fabricated aluminum	Polished	Chrome		PCE314.1116						
							Clear anodized		PCE314.1114						
							Natural	Plain	Yes	PCE314.1113					
							Polished	Yes	PCE314.1117						
							Clear anodized		PCE314.1143						
							Carbon Fiber		PCE314.1185						
			bf.	-	Fabricated aluminum	Polished	Plain	No	PCE314.1118						
							Clear anodized		PCE314.1115						
			bg.	-	Fabricated aluminum	Polished	Natural	Plain	Yes - Tube Tos	PCE314.1120					
							Polished	Yes	PCE314.1121						
Ford 302 351C Cleveland	Perimeter bolt	Stock	bh.	-	Steel	Chrome	Plain	Yes	PCE314.1043						
									bi.	-	Cast aluminum	Polished	Plain	Yes	PCE314.1088
													Ball-milled	Yes	PCE314.1090
													Black wrinkle		PCE314.1089
													Black wrinkle Blue powdercoated	Yes	PCE314.1154
									bj.	-	Fabricated aluminum	Polished	Procomp Electronics logo	Yes	PCE314.1153
													Ford Racing logo	Yes	PCE314.1151
													Black wrinkle		PCE314.1152
													Clear anodized	Yes	PCE314.1136
									bk.	-	Fabricated aluminum	Clear anodized	Plain	Yes	PCE314.1148
													Clear anodized	No	PCE314.1135
									bl.	-	Steel	Chrome	Plain	Yes	PCE314.1134
Yes	PCE314.1045														
Ford 429 460	Perimeter bolt	Tall	bm.	-	Cast aluminum	Polished	Plain	Yes	PCE314.1091						
							Ball-milled	Yes	PCE314.1092						
							Long Bolt	Yes	PCE314.1155						
Ford 240 300 I6 1965-87	Perimeter bolt	Stock	bo.	-	Steel	Chrome	Plain	Yes - Tube Tos	PCE314.1049						
Ford Fe 390 427 428	Perimeter bolt	Stock	bp.	-	Steel	Chrome	Plain	Yes	PCE314.1044						
GM LSX LS1 LS2 LS3 LS6 LS7	Centerbolt	Tall	ca.	-	Fabricated aluminum	Polished	Plain	-	PCE314.1132						
							Clear anodized		PCE314.1146						
							cb.	Coil Mount Plate Only	Fabricated aluminum	Clear anodized	-	-	PCE314.1133		
											Polished		PCE314.1131		
							cc.	-	Fabricated aluminum	Clear anodized	Plain	-	PCE314.1147		
											Natural		PCE314.1130		
Holden 253 304 308	Perimeter bolt	Tall	cd.	-	Fabricated aluminum	Polished	-	-	PCE314.1161						
							ce.	VN Heads	Cast aluminum	Polished	Plain	Yes	PCE314.1093		
							cf.	304 Heads	Fabricated aluminum	Clear anodized	Plain	Yes	PCE314.1123		
											Polished	Yes	PCE314.1124		
cg.	308 Heads	Fabricated aluminum	Polished	Plain	Yes	PCE314.1122									

Application	Valve Cover Mounting Style	Valve Cover Height	Ref.	Notes	Valve Cover Material	Valve Cover Finish	Valve Cover Top Style	Breather Hole	SKU						
Mopar Chrysler 170 198 225 Slant 6	Perimeter bolt	Stock	ch.	-	Steel	Chrome	Plain	Yes	PCE314.1058						
		Stock	ci.	-	Steel	Chrome	Plain	Yes	PCE314.1046						
		Tall	cj.	-	Fabricated aluminum	Natural		PCE314.1125							
						Polished	Plain	Yes	PCE314.1127						
Mopar Chrysler SB 318 340 360	Perimeter bolt	Stock	ck.	-	Fabricated aluminum	Clear anodized		PCE314.1144							
						Chrome	Plain	Yes	PCE314.1126						
						cl.	-	Steel	Chrome	Plain	Yes	PCE314.1047			
												Natural		PCE314.1128	
Mopar Chrysler BB 383 440	Perimeter bolt	Tall	cm.	-	Fabricated aluminum	Polished	Plain	Yes	PCE314.1129						
						Clear anodized		PCE314.1145							
Oldsmobile 350 400 425 455	Perimeter bolt	Stock	cn.	-	Steel	Chrome	Plain	Yes	PCE314.1051						
		Tall	co.	-	Fabricated aluminum	Polished	Plain	No	PCE314.1171						
						Steel	Chrome	Plain	Yes	PCE314.1048					
Pontiac 326 400 455	Perimeter bolt	Tall	cq.	-	Cast aluminum	Polished	Finned	Yes	PCE314.1162						
									cr.	-	Cast aluminum	Polished	Finned	No	PCE314.1163
															-
Chrysler Hemi 426 Alcohol	Perimeter bolt	-	ct.	-	Fabricated aluminum	Polished	Plain	-	PCE314.1139						
									-	-	Fabricated aluminum	Polished	Plain	-	PCE314.1138
															-
									-	-	-	-	PCE314.1001		
Amc 304 360 390 401 1968-79	Perimeter bolt	3.125 in.	cu.	-	Steel	Chrome	Plain	No	PCE314.1036						
Cadillac 368 425 500 1968-84	Perimeter bolt	Stock	cv.	-	Steel	Chrome	Plain	Yes	PCE314.1059						

Valve Cover Baffles

These Speedmaster™ valve cover baffles are direct replacement baffles for Speedmaster valve covers. You can depend on Speedmaster™ for the valve cover accessories that you need.

Application	Baffle Type	Baffle Material	SKU
Chevrolet SBC 350	Bolt-in	Steel	PCE480.1001



Valve Cover Gaskets

Rubber

These Speedmaster™ valve cover gaskets are manufactured from high quality rubber, which is molded over and vulcanized to a rigid steel frame. They won't leak, blow out, or get sucked in, the way stock or inferior-quality aftermarket gaskets can. These gaskets feature superior-quality rubber and steel design to provide years of dependable service, especially if you frequently have to remove and reinstall the valve covers.



Cork

Cork has been a reliable gasket material for longer than most of us have been alive. It's strong and reliable, and it gets the job done just fine in stock and mild performance rebuilds. So it should be no surprise that we've chosen it for our stock-replacement Speedmaster™ valve cover gaskets. If you're doing a rebuild, or if you've got to replace your valve cover gaskets, chances are they're just what you need.



Application	Gasket Material	Thickness	SKU
Chevrolet SBC 350 1955-85	Black Rubber w/ steel core	0.172 in.	PCE353.1009
	Blue Rubber w/ steel core	0.172 in.	PCE353.1010
	Cork	0.313 in.	PCE353.1007
Chevrolet SBC 350 1986-97	Cork/Rubber w/ steel core	0.250 in.	PCE353.1008
	Black Rubber	0.125 in.	PCE353.1001
Chevrolet BBC 454 1966-00	Cork	0.313 in.	PCE353.1018
	Black Rubber w/ steel core	0.188 in.	PCE353.1012
Ford 302 351C Cleveland	Black Rubber w/ steel core	0.313 in.	PCE353.1013
	Cork/Rubber coated	0.172 in.	PCE353.1019
Ford SB 289 302 Windsor	Black Rubber w/ steel core	0.172 in.	PCE353.1011
	Blue Rubber w/ steel core	0.172 in.	PCE353.1006
Holden 253 304 308	Cork	0.313 in.	PCE353.1014
	Cork	0.313 in.	PCE353.1016
Holden 304	Paper with silicone coating	0.100 in.	PCE353.1015

Valve Covers Accessories

Valve Cover Breathers

Speedmaster™ valve cover breathers are just the thing to prevent oil splash while adding some style. Speedmaster™ breathers keep your crankcase properly vented and add a little shine under the hood. They are available in a wide variety of styles for many applications.



Ref.	Valve Cover Breather Attachment	PCV Valve	Breather Tube	Shielded	Breather Top Style	Grommets Included	Fits Hole Size	Top Material	Top Finish	Base Material	Base Finish	SKU
a.	Push-in						1.500 in.				Chrome	PCE309.1001
	Twist-on	No	No	No	Plain	No	1.500 in.	Steel	Chrome	Steel	Natural	PCE309.1002
b.	Push-in						1.250 in.				Natural	PCE309.1003
	Push-in	No	Yes	No	Plain	No	1.250 in.	Steel	Chrome	Steel	Chrome	PCE309.1010
c.	Clamp-on (1 3/8")						1.375 in.					PCE309.1004
	Clamp-on (1 1/2")	No	No	Yes	Plain	No	1.500 in.	Steel	Chrome	Rubber	Black	PCE309.1005
d.	Push-in						1.250 in.					PCE309.1012
	Clamp-on (1 3/8")						1.375 in.					PCE309.1013
	Clamp-on (1 1/2")	No	No	No	Plain	No	1.500 in.	Steel	Chrome	Rubber	Black	PCE309.1014
e.	Push-in	No	No	No	Plain	No	1.250 in.	Aluminum	Polished	Aluminum	Natural	PCE309.1006
	Push-in	No	No	No	Ball-milled	No	1.250 in.	Aluminum	Polished	Aluminum	Natural	PCE309.1007
f.	Push-in	No	No	No	Ball-milled	No	1.250 in.	Aluminum	Polished	Aluminum	Natural	PCE309.1016
	Push-in	No	No	No	Plain	Yes	1.250 in.	Aluminum	Polished	Aluminum	Natural	PCE309.1017
g.	Push-in	No	No	No	Plain	No	1.250 in.	Aluminum	Polished	Aluminum	Natural	PCE309.1008
h.	Push-in	No	Yes	No	Plain	No	1.250 in.	Aluminum	Polished	Aluminum	Natural	PCE309.1009
i.	Push-in	No	Yes	No	Ball-milled	No	1.250 in.	Aluminum	Polished	Aluminum	Natural	PCE309.1015
j.	Push-in	No	Yes	No	Plain	Yes	1.250 in.	Aluminum	Natural	Aluminum	Natural	PCE309.1015
k.	Push-in	Yes	Yes	No	Plain	No	1.250 in.	Aluminum	Natural	Aluminum	Natural	PCE309.1018
l.	Push-in	No	No	No	Finned	No	1.000 in.	Aluminum	Polished	Aluminum	Natural	PCE309.1019
m.	Push-in	No	Yes	No	Finned	No	1.250 in.	Aluminum	Polished	Aluminum	Natural	PCE309.1020

Valve Cover Grommets

Speedmaster™ valve cover grommets are designed to control oil leakage into breather caps. Plus, they keep oil from getting all over your valve covers. The baffled grommets help to eliminate oil blowby as well. These neoprene grommets are made to fit most stamped or die-cast valve covers. They are available in breather and PCV styles to fit your application needs.



Ref.	Grommet Style	Outside Diameter	Inside Diameter	SKU
a.	Breather	1.000 in.	0.5625 in.	PCE311.1010
		1.000 in.	0.750 in.	PCE311.1011
		1.250 in.	0.750 in.	PCE311.1006
		1.250 in.	0.9375 in.	PCE311.1005
		1.250 in.	1.000 in.	PCE311.1004
b.	Breather Plug	1.375 in.	0.750 in.	PCE311.1007
		1.250 in.	0.750 in.	PCE311.1003
c.	PCV	1.250 in.	0.750 in.	PCE311.1009
		1.250 in.	1.000 in.	PCE311.1008

Valve Cover Fasteners

Want to add a bit of flash to your engine? These valve cover fasteners from Speedmaster™ not only anchor your valve covers, they look great, too. They're available in a variety of styles to suit your needs..



Ref.	Valve Cover Fastener Style	Fastener Material	Fastener Finish	Fastener Head Style	Thread Size	Quantity	Notes	SKU
a.	Wing nut	Steel	Chrome	Extended T-bar	1/4-20 in.	Set of 4.	5.375 in. overall length.	PCE310.1001
					5/16-18 in.			PCE310.1007
b.	Wing nut	Aluminum/Steel	Red anodized	Extended T-bar	1/4-20 in.	Set of 4.	5.375 in. overall length.	PCE310.1015
c.	Wing nut	Steel	Chrome	Y-top	1/4-20 in.	Set of 4.	3.500 in. overall length.	PCE310.1013
					5/16-18 in.			PCE310.1014
d.	Stud	Steel	Chrome	Hex	1/4-20 in.	Set of 4.	1.375 in. overall length.	PCE310.1002
					Set of 8.	PCE310.1009		
e.	Stud	Steel	Chrome	Hex	1/4-20 in.	Set of 4.	4.250 inch overall length.	PCE310.1006
f.	Bolt	Steel	Chrome	Allen	1/4-20 in.	Set of 8.	Designed for tall aluminum covers only.	PCE310.1011
g.	Bolt	Stainless Steel	Chrome	Allen	1/4-20 in.	Set of 8.	-	PCE310.1003
h.	Bolt	Stainless Steel	Chrome	Hex	1/4-20 in.	Set of 14.	Short	PCE310.1004
i.	Bolt	Stainless Steel	Chrome	Hex	1/4-20 in.	Set of 14.	8- Short 6-Long	PCE310.1005
j.	Bolt	Steel	Chrome	Hex	1/4-20 in.	Set of 8.	Will not work with tall valve covers.	PCE310.1008

Hold-Down Tabs

Speedmaster™ valve cover spreader bars are designed to spread the fastener load over a larger area of your valve cover flange. This minimizes distortion and decreases the possibility of oil leaks. They match the rest of your chrome accessories and are available for a wide variety of applications.



Application	Quantity	SKU
Chevrolet SBC 350	Sold as a set of 4.	PCE312.1001
Chevrolet BBC 454	Sold as a set of 7.	PCE312.1002
Ford SB 289 302 351 Windsor	Sold as a set of 6.	PCE312.1003

Oil Fill Caps

These Speedmaster™ oil fill caps are a great looking way to add some class under the hood while topping-off your oil system. They are designed to be pushed into your standard 1.25 in. valve cover breather hole. They do not include the rubber grommet.



Based on a positive retention system, these Speedmaster™ billet oil filler caps allow you to have oil filler access that provides a leakproof seal. They utilize O-ring sealing and are manufactured from high-quality billet aluminum. Speedmaster™ billet oil filler caps are an excellent choice for your high performance engine.

Ref.	Oil Cap Attachment	Oil Cap Material	Oil Cap Finish	SKU
a.	Push in	Aluminum	Polished	PCE313.1001
b.	Screw-in	Billet Aluminum	Blue anodized	PCE313.1002

Pulley Kits

Long Lasting Durability

If you're rebuilding, upgrading, doing maintenance, seeking better performance or just trying to make the proper decision, we are the company you can turn to for guaranteed satisfaction. Our pulley systems are built in a way to help minimize stress during installation.

When working on your engine you are presented with a number of options to make things work according to your needs and specifications. Having high performance pulley systems in place is crucial to improving power and maximizing efficiency.

Engine Pulley Systems

The successful formula of offering a complete engine drive accessory kit has now been applied to the Speedmaster™ pulley systems. Superior engineering, high-tech styling, and quality components are combined into a precision-machined compact package. Once again, true innovation is the key, from the patent-pending compressor manifold to the stainless hardware. Speedmaster™ pulley systems work with any type of cylinder head or manifold configuration. They are made from high quality Billet Aluminum, with a polished finish guaranteed to draw attention to your engine.



Application	Pulley Style	Crankshaft Pulley Included	Water Pump Pulley Included	Power Steering Pulley Included	Power Steering Pulley Attachment	Power Steering Brackets Included	Alternator Pulley Included	Alternator Fan Included	Alternator Nose Cover Included	Alternator Brackets Included	Air Conditioning Pulley Included	Air Conditioning Cover Included	Air Conditioning Bracket Included	SKU
Chevrolet SBC 350	V-belt	Yes 2-groove	Yes 2-groove	Yes 1-groove	Keyway	Yes	No	No	No	No	Yes 1-groove	Yes	Yes	PCE415.1021
Chevrolet BBC 454	Serpentine	Yes 6-groove	Yes	Yes 6-groove	Keyway	Yes	Yes 6-groove	Yes	Yes	Yes	Yes 6-groove	Yes	Yes	PCE415.1020

Underdrive Pulley Set

Speedmaster™ underdrive pulley kits are built from aircraft-quality material and computer-machined. By reducing the speed of the accessories, these underdrive pulleys free up an average of 8-15 horsepower, while retaining full cooling and charging characteristics. Most kits can be bolted on in less than 30 minutes.



Application	Pulley Style	Pulley Set Style	Crankshaft Pulley Included	Water Pump Pulley Included	Alternator Pulley Included	Belt Included	Pulley Finish	SKU
1979-1993 Ford 5.0 **	Serpentine	Performance ratio	Yes, 6-groove, serpentine	Yes, Non-ribbed	Yes, 6-groove, serpentine	No	Black	PCE415.1022
							Chrome	PCE415.1025

** = Will also fit 1986-1996 302 and 351w Ford F Series Truck

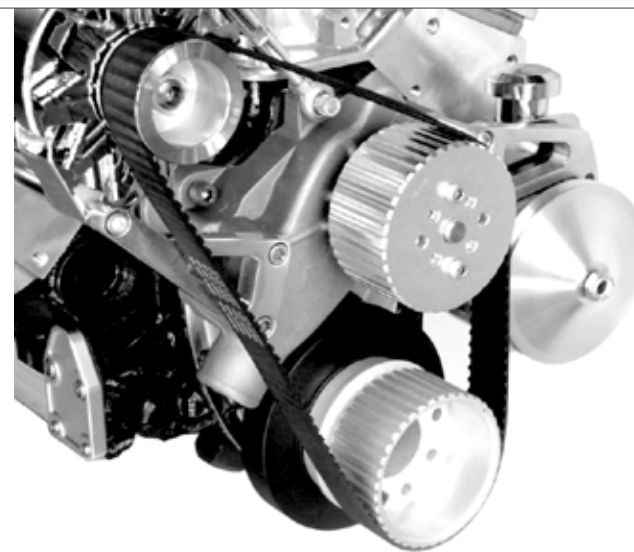

Gilmer Drive Kit

Speedmaster™ gilmer drive kits are aluminum machined and precision made for your street/race engines; Complete with a 1.5 in. wide belt to eliminate belt slippage that is common with V-belt systems. Speedmaster™ gilmer drive belts are designed to keep your accessory drive operating properly. They provide higher power and torque transmission, improved meshing to reduce tooth jump, greater resistance to tooth shear, and reduced friction to extend their life. The belts use a fiberglass cord wound across the entire width of the belts to minimize stretching. Speedmaster™ gilmer drive belts are manufactured from a synthetic neoprene compound that resists heat, oils, ozone, and aging. Tough nylon fabric is then bonded to the tooth surface for greater wear resistance.

Application	Crankshaft Pulley	Water Pump Pulley	Power Steering Provision	Alternator Pulley	Air Conditioning Pulley	Belt Included	Belt Length (in)	Notes	SKU
Chevrolet SBC 350	Yes	Yes	No	Yes	No	Yes	40.500 in.	Short Water Pump Swp	PCE415.1001
			Yes					Long Water Pump Lwp	PCE415.1002
Chevrolet BBC 454	Yes	Yes	Yes	Yes	No	Yes	40.500 in.	-	PCE415.1003
Ford 6 Cylinder	Yes	Yes	No	Yes	No	Yes	39.000 in.	-	PCE415.1005
Ford SB 289 302 351 Windsor	Yes	Yes	Yes	Yes	No	Yes	40.500 in.	-	PCE415.1004
Ford 302 351C Cleveland	Yes	Yes	Yes	Yes	No	Yes	40.500 in.	-	PCE415.1006
Ford 429 460	Yes	Yes	Yes	Yes	No	Yes	42.000 in.	-	PCE415.1007
Mopar Chrysler SB 318 340 360	Yes	Yes	No	Yes	No	Yes	39.000 in.	Gilmer drive adapter pulley included.	PCE415.1008
Mopar Chrysler BB 383 440	Yes	Yes	No	Yes	No	Yes	40.500 in.	Gilmer drive adapter pulley included.	PCE415.1009
Holden 186 202 6 Cylinder	Yes	Yes	No	Yes	No	Yes	32.000 in.	Aluminum fan spacer included.	PCE415.1015
			No		No				PCE415.1010
Holden 253 304 308	Yes	Yes	Yes	Yes	No	Yes	42.000 in.	-	PCE415.1017
			Yes		Yes				PCE415.1018
Mazda 12A 13B Rx2 Rx3 Rx4 Rx7	Yes	Yes	No	Yes	No	Yes	30.000 in.	-	PCE415.1016



Alternator Pulleys

Speedmaster™ alternator pulleys are manufactured from quality aluminum or chrome plated steel to ensure strength and durability. They are designed to ensure belt retention at high rpm.

V-belt



Serpentine



Gilmer



Pulley Style	Ref.	Groove Quantity	Alternator Fan Included	Alternator Nose Cover Included	Alternator Pulley Attachment Style	Pulley Material	Pulley Finish	SKU
V-belt	a.	1	Yes	Yes	Bolt-on	Aluminum	Silver	PCE238.1007
	b.	2	Yes	Yes	Bolt-on	Aluminum	Silver	PCE238.1008
	c.	1	Yes	No	Bolt-on	Steel	Chrome	PCE238.1001
	d.	1	No	Yes	Bolt-on	Aluminum	Machined	PCE238.1002
Serpentine	e.	6	Yes	Yes	Bolt-on	Aluminum	Silver	PCE238.1004
							Red	PCE238.1005
							Blue	PCE238.1006
Gilmer	f.	Gilmer	No	No	Bolt-on	Steel	Chrome	PCE238.1003

Power Steering Pulleys

Speedmaster™ power steering pulleys are made from polished aluminum. They're available in both press-fit and keyway mounting styles for most Chevy, Ford, and Chrysler applications.



Application	Ref.	Pulley Style	Pulley Grooves	Pulley Attachment	Outside Diameter (in)	Pulley Material	Pulley Finish	SKU
Chevrolet GM	a.	V-belt	1-groove, V-belt	Keyway	6.000 in.	Aluminum	Machined	PCE240.1001
	b.	V-belt	1-groove, V-belt	Bolt on and Adjustable	4.640 in.	Aluminum	Machined	PCE240.1004
Holden (Gilmer)	c.	V-belt	1-groove, V-belt	Bolt on	4.640 in.	Aluminum	Machined	PCE240.1003

Crankshaft Pulleys

Need some good-looking pulleys for your street ride? Take your choice of Speedmaster™ chrome plated steel or billet aluminum crankshaft pulleys. Speedmaster™ crankshaft pulleys help increase horsepower by reducing accessory drag and are available in different offsets and groove combinations to suit most applications.

V-belt Aluminum

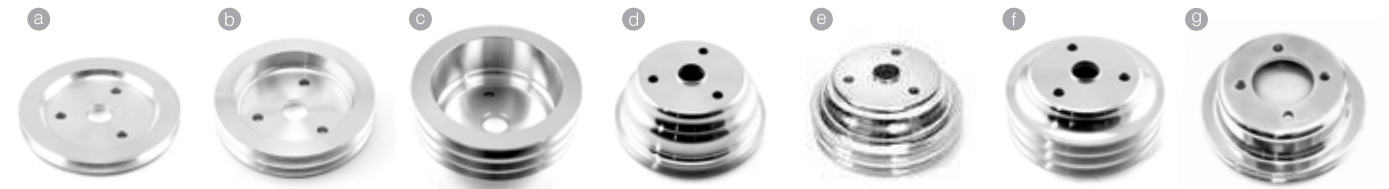

V-belt Steel



Gilmer



Belt Drive



Pulley Style	Application	Ref.	Water Pump Style	Groove Quantity	Outside Diameter (in)	Pulley Material	Pulley Finish	SKU			
V-belt	Chevrolet SBC 350	a.	Short	1	6.600 in.	Billet Aluminum	Natural	PCE239.1007			
		b.		2				PCE239.1008			
		c.		3				PCE239.1006			
		h.		1				6.800 in.	Steel	Chrome	PCE239.1012
		d.		1				6.600 in.	Billet Aluminum	Natural	PCE239.1009
	e.	2	6.600 in.	Billet Aluminum	Natural	PCE239.1010					
	f.	3	6.600 in.	Billet Aluminum	Natural	PCE239.1011					
	i.	1	6.800 in.	Steel	Chrome	PCE239.1013					
	j.	2	6.900 in.	Steel	Chrome	PCE239.1014					
	k.	3	7.800 in.	Steel	Chrome	PCE239.1015					
Chevrolet BBC 454	-	a.	Short	1	7.000 in.	Billet Aluminum	Natural	PCE239.1001			
		b.		2	7.000 in.	Billet Aluminum	Natural	PCE239.1002			
		c.		3	7.000 in.	Billet Aluminum	Natural	PCE239.1005			
		e.		2	7.000 in.	Billet Aluminum	Natural	PCE239.1003			
		f.		3	7.000 in.	Billet Aluminum	Natural	PCE239.1004			
l.	3	7.800 in.	Steel	Chrome	PCE239.1016						
Ford 302 351C Cleveland	-	g.	-	1	6.700 in.	Billet Aluminum	Polished	PCE246.1008			
Gilmer	Universal	m.	Short	-	-	Aluminum	Natural	PCE239.1019			
		n.	Long	-	-	Aluminum	Natural	PCE239.1018			
Belt Drive	Ford SB 289 302 Windsor	o.	-	-	-	Steel	Natural	PCE239.1017			

Water Pump Pulleys

Speedmaster™ water pump pulleys can really dress up your engine's accessories, as well as your vehicle's engine compartment. They feature a durable, high-shine, chrome plated or polished billet alloy finish that adds the brilliant sparkle you're seeking. They're available for most models and come in a variety of groove and offsets to suit your application.

V-belt



Pulley Style	Application	Ref.	Water Pump Style	Groove Quantity	Pulley Material	Pulley Finish	Outside Diameter (in)	SKU
V-belt	Chevrolet SBC 350	a.	Short	1	Billet Aluminum	Machined	6.600 in.	PCE246.1003
		c.		2				PCE246.1004
		e.	Long	1	Steel	Chrome	6.600 in.	PCE246.1009
		b.		1				Billet Aluminum
	d.	2	PCE246.1006					
	f.	1	Steel	Chrome	6.625 in.	PCE246.1010		
	Chevrolet BBC 454	a.	Short	1	Billet Aluminum	Machined	6.438 in.	PCE246.1001
		c.	2	PCE246.1002				
	Ford 302 351C Cleveland	g.	Long	2	Steel	Chrome	6.300 in.	PCE246.1011
		h.	-	1				Billet Aluminum
Gilmer	Universal	i.	-	-	Aluminum	Machined	-	PCE246.1012

Replacement Gilmer Drive Belts

Speedmaster™ gilmer drive belts are designed to keep your accessory drive operating properly. They provide higher power and torque transmission, improved meshing to reduce tooth jump, greater resistance to tooth shear, and reduced friction to extend their life. The belts use a fiberglass cord wound across the entire width of the belts to minimize stretching. Speedmaster™ gilmer drive belts are manufactured from a synthetic neoprene compound that resists heat, oils, ozone, and aging. Tough nylon fabric is then bonded to the tooth surface for greater wear resistance.



All belts are 1.500 in. Wide.

Belt Length (in)	30.000 in.	32.000 in.	32.200 in.	34.500 in.	36.700 in.	39.000 in.	40.500 in.	42.000 in.	45.000 in.	48.000 in.	51.000 in.
SKU	PCE237.1001	PCE237.1002	PCE237.1003	PCE237.1004	PCE237.1005	PCE237.1006	PCE237.1007	PCE237.1008	PCE237.1009	PCE237.1010	PCE237.1011

Pulley Accessories

Pulley Spacers & Adapters

Aligning your pulleys just got a bit easier with Speedmaster™ pulley spacers & adapters. Speedmaster™ spacers are specifically designed to help achieve proper belt alignment. They're machined from billet aluminum for lasting durability.



Ref.	Application	Spacer Type	Pulley Spacer Material	Pulley Spacer Finish	Pulley Spacer Thickness (in)	SKU
a.	Universal	Gilmer Drive Crankshaft	Billet Aluminum	Machined	0.500 in.	PCE415.1011
b.	Universal	Gilmer Drive Crankshaft	Billet Aluminum	Machined	2.000 in.	PCE244.1005
c.	Mopar Chrysler SB 318 340 360 BB 383 440	Gilmer Drive Pulley	Billet Aluminum	Machined	2.350 in.	PCE244.1006
d.	Mopar Chrysler SB 318 340 360 BB 383 440	Gilmer Drive Pulley	Billet Aluminum	Machined	0.500 in.	PCE241.1001
e.	Universal	Radiator Fan	Billet Aluminum	Red anodized	1.000 in.	PCE183.1001

Pulley Bolts

Speedmaster™ pulley bolts come in black oxidized chromoly. They are rated at high tensile strength and are guaranteed to provide the reliability required for race and high performance street applications.



Application	Fastener Style	Head Style	Thread Size	Underhead Length (in)	Fastener Material	Fastener Finish	SKU
Holden	Gilmer Drive	Internal Allen	5/16 in.	1.250 in.	Steel	Black oxide	PCE242.1001
				4.000 in.			PCE242.1002
Ford	Gilmer Drive	Internal Allen	3/8-16 in.	2.750 in.	Steel	Black oxide	PCE242.1003
Chevrolet	Gilmer Drive	Internal Allen	3/8-24 in.	3.000 in.	Steel	Black oxide	PCE242.1004

Pulley Nose Cones

Speedmaster™ machined aluminum water pump pulley nose cones are constructed from top-quality 356 aluminum alloy that's heat-treated to T6 specifications. This durable material is corrosion-resistant, keeping your pulleys looking great for many years to come.



Nose Cone Position	Nose Cone Material	Nose Cone Finish	Water Pump Style	SKU
Water pump pulley	Billet Aluminum	Machined	Short	PCE243.1001
			Long	PCE243.1002

Accessory Brackets

Alternator Brackets

Don't trust any old brackets to hold your alternator. Use Speedmaster™ alternator brackets to keep your alternator firmly in place and your belts in line. Speedmaster™ alternator brackets are designed to mount the alternator in several positions depending on your application. These brackets are made from heavy gauge steel to prevent flex or high quality heat treated alloy. Then highly polished or chrome plated for lasting beauty. They are available in several styles depending on your application needs.

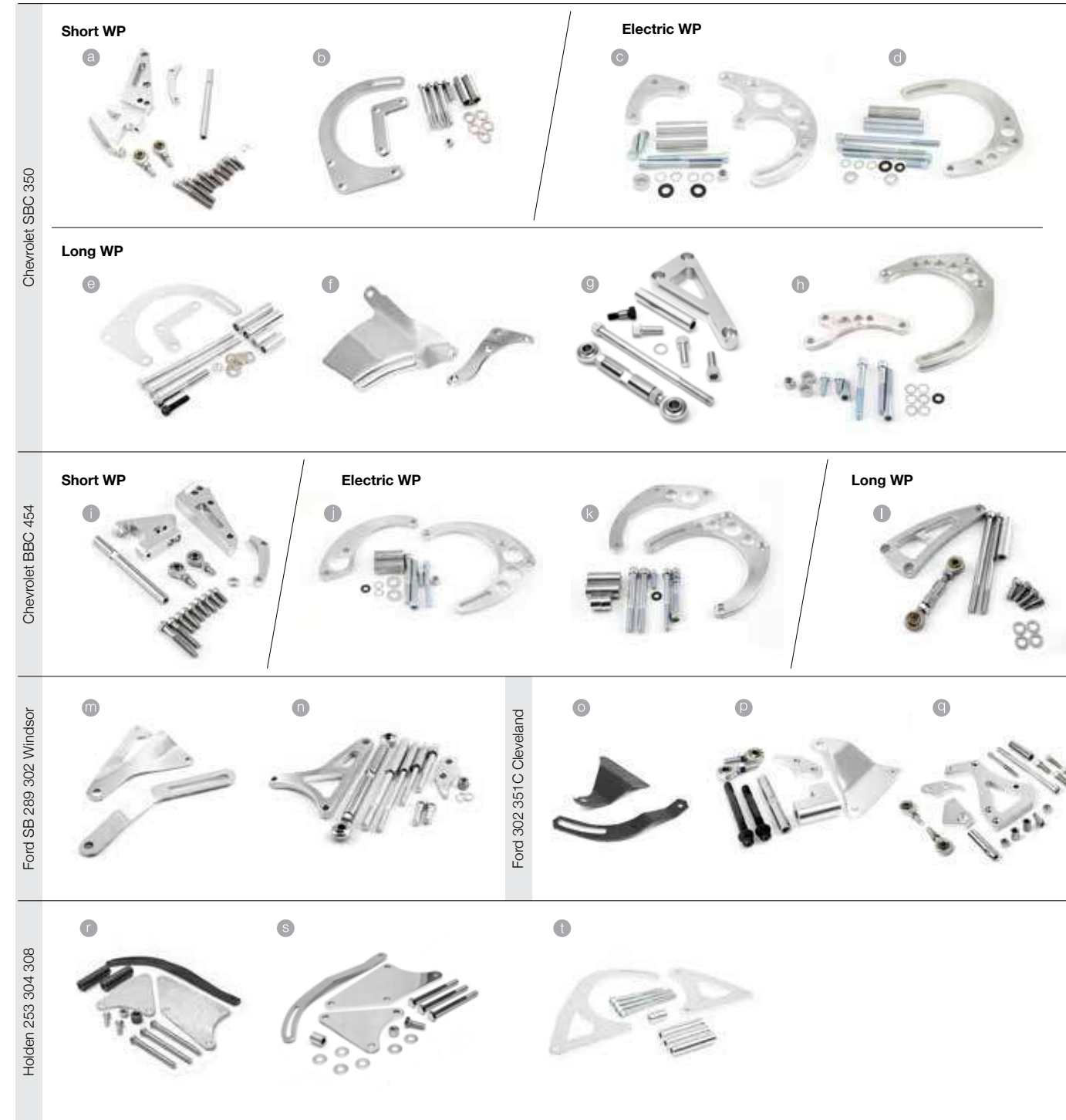

Application	Ref.	Water Pump Style	Alternator Mounting Location	Mounting Position	Lower Bracket Mounting Style	Bracket Material	Bracket Finish	SKU		
Chevrolet SBC 350	a.	Short	Driver side (US)	High mount	Water pump mount	Aluminum	Polished	PCE232.1003		
	b.			Low mount	Front cover mount	Steel	Chrome plated	PCE232.1005		
	e.			Low mount	Front cover mount	Steel	Chrome plated	PCE232.1006		
	f.	Long	Passenger side (US)	High mount	Water pump mount	Steel	Chrome plated	PCE232.1007		
	g.			High mount	Water pump mount			Aluminum	Polished	PCE232.1002
	c.			Electric or Long	Driver side (US)	Low mount	Engine block front mount	Billet Aluminum	Natural	PCE232.1025
d.	Electric	Passenger side (US)	Mid mount	Water pump mount	PCE232.1024					
Chevrolet SBC 350 (Camel Hump & Fuelie)	h.	Long	Passenger side (US)	Mid mount	Water Pump Mount	Billet Aluminum	Natural	PCE232.1022		
	i.	Short	Driver side (US)	High mount	Water pump mount	Aluminum	Polished	PCE232.1011		
Chevrolet BBC 454	j.	Electric or Short	Driver side (US)	Low mount	Head Mount	Billet Aluminum	Clear anodized	PCE232.1021		
	k.			Low mount	Engine block front mount			PCE232.1026		
Ford SB 289 302 Windsor	l.	Long	Passenger side (US)	High mount	Water pump mount	Aluminum	Polished	PCE232.1004		
	m.	STD	Passenger side (US)	Low mount	Cylinder head mount	Steel	Chrome plated	PCE232.1018		
n.	High mount			Aluminum		Clear anodized	PCE232.1001			
Ford 302 351C Cleveland	o.	STD	Passenger side (US)	Mid mount	Water pump mount	Steel	Satin	PCE232.1012		
	p.			Mid mount		Aluminum	Polished	PCE232.1027		
	q.			Mid mount		Billet aluminum	Clear anodized	PCE232.1017		
Holden 253 304 308	r.	Short & Long	Driver side (AU)	Low mount	Water pump mount	Steel	Satin	PCE232.1009		
	s.						Polished	PCE232.1010		
	t.			Both sides		Low mount	Water pump mount	Billet aluminum	Polished	PCE232.1016

Power Steering Brackets

Speedmaster™ universal power steering pump brackets mount GM self-contained power steering pumps low on the block for a compact installation and good looks. Use existing bolt holes to mount these brackets with the included hardware.



Application	Ref.	Power Steering Pump Model	Bracket Style	Pump Mounting Position	Bracket Material	Bracket Finish	SKU
Chevrolet SBC 350	a.	Saginaw	Upper and lower	Driver side (US)	Steel and Aluminum	Chrome	PCE233.1001
	b.				Billet Aluminum	Polished	PCE233.1006
	c.	GM Type 2	Front and rear	Driver side (US)	Billet Aluminum	Polished	PCE233.1004
	d.				Billet Aluminum	Polished	PCE233.1005
Chevrolet BBC 454	e.	Saginaw	Front and rear	Driver side (US)	Steel	Chrome	PCE233.1003
Ford SB 289 302 Windsor	F.	Saginaw	Upper and lower	Driver side (US)	Steel	Chrome	PCE233.1002

Air Conditioner Brackets

Speedmaster™ air conditioning brackets are created with an eye for great show-quality styling. They can provide your custom automotive project with a unique, professional eye-appealing look.



Application	Fits A/C Compressor Style	Power Steering Pump Mounting Position	Water Pump Style	Bracket Material	Bracket Finish	Bracket Designed for Headers	SKU
Chevrolet BBC 454	Sanden 508	Passenger Side (US)	Short Only	Aluminum	Polished	Yes	PCE511.1001

Oiling System



Quick Tip

Oil Pumps

The oiling system addresses the need to properly lubricate an engine when it's running. Properly lubricating an engine not only reduces friction between moving parts but is also the main method by which heat is removed from pistons, bearings, and shafts. Failing to properly lubricate an engine will result in engine failure. Avoid problems with a high-quality oil pump from Speedmaster™.

Note: Hardened driveshaft recommended for high-volume oil pumps.

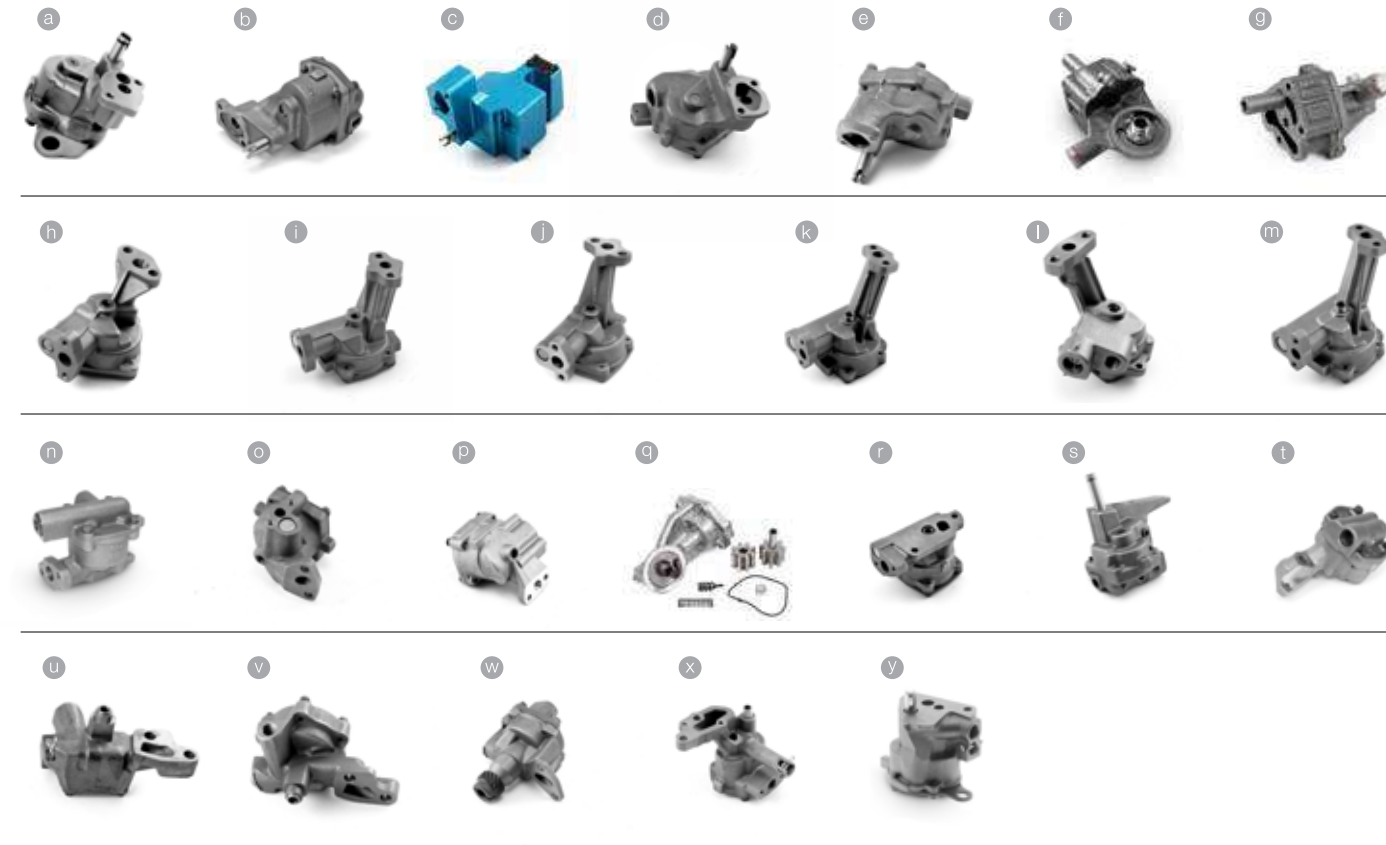

Standard-volume

Speedmaster™ oil pumps are manufactured from high-quality steel with all new components. They are individually hand turned and pressure tested to exceed performance standards.

High-volume

Speedmaster™ high-volume oil pumps give you an additional 20 to 25 percent of much-needed oil volume for your performance application. Speedmaster™ oil pumps are manufactured from high-quality steel with all new components. They are individually hand turned and pressure tested to exceed performance standards.

Billet High-volume

If you are serious about building the ultimate wet sump system, then these Speedmaster one-piece billet aluminum oil pumps with their integral screen pickup are the only way to go. Speedmaster billet aluminum oil pumps are designed to maintain adequate oil volume in the harshest racing environments. Manufactured from T6-6061 billet aluminum, these pumps feature aircraft-quality chromoly gear shafts to eliminate fatigue due to vibration, and a chromoly sleeve and wear plate. Precision-machined steel billet gears ensure a perfect mesh and can withstand the stresses of the extreme rpm range in race engines. These pumps not only eliminate the potential disaster of the oil pump pickup falling off, but they also offer smoother oil flow with less internal drag, resulting in an actual increase of 5 to 6 hp. These oil pumps are the absolute latest in cutting-edge technology.

Additional features include:

- Billet aluminum housing and cover with anodized hardcoat.
- High-volume pump gears.
- Its mounting boss has three times the volume of stock to eliminate fatigue failure.
- Chromoly driveshaft extended into the pump cover for support.
- Bypass returns oil to the pickup to reduce aeration and temperature.
- Robust CNC-manufactured design.
- The pick up screen is built into the pump.

Wet vs. Dry Oil Systems

Wet sump systems store the oil in the pan but a dry sump system stores it in a separate tank and pumps the pan clean leaving it essentially "dry". The usual set up for a dry sump system uses all but one of the stages to scavenge oil from the pan and the last stage is used to pump oil from the motor.

Application	Ref.	Oil Pump Line	Oil Pump Style	Oil Pump Pressure	Replaces	SKU
Chevrolet SBC 350	a.	Standard-volume		Standard-pressure	M55	PCE303.1001
	b.	High-volume	Wet sump	High-pressure	M55HV	PCE303.1002
	c.	Billet High-volume		High-pressure	10050-750SS	PCE303.1016
Chevrolet BBC 396 454	d.	Standard-volume	Wet sump	Standard-pressure	M77	PCE303.1008
	e.	High-volume			M77HV	PCE303.1009
Holden 253 304 308	f.	Standard-volume	Wet sump	Standard-pressure	JP9471	PCE303.1014
	g.	High-volume		Standard-pressure	JP9491	PCE303.1015
Ford FE 332 352 390 427 428	h.	Standard-volume	Wet sump	Standard-pressure	M57	PCE303.1003
	i.	Standard-volume	Wet sump	Standard-pressure	M68	PCE303.1004
Ford 289 302W Windsor	j.	High-volume			M68HV	PCE303.1005
	k.	Standard-volume	Wet sump	Standard-pressure	M83	PCE303.1010
Ford 351W Windsor	l.	Standard-volume	Wet sump	Standard-pressure	M84A	PCE303.1011
	m.	High-volume			M84AHV	PCE303.1012
Ford Mercury 2.3L 4-Cylinder	n.	Standard-volume	Wet sump	Standard-pressure	M127	PCE303.1025
Ford Mercury 2.8L 6-Cylinder Saab 1.7L 4-Cylinder	o.	Standard-volume	Wet sump	Standard-pressure	M87	PCE303.1024
Ford Mercury 2.9L 4.0L 6-Cylinder	p.	Standard-volume	Wet sump	Standard-pressure	M128	PCE303.1021
Ford Mercury 3.8L 4.2L 6-Cylinder	q.	Standard-volume	Wet sump	Standard-pressure	M246	PCE303.1018
Ford Mercury 4-Cylinder	r.	Standard-volume	Wet sump	Standard-pressure	M86C	PCE303.1013
GM Isuzu 2.2L 4-Cylinder	s.	Standard-volume	Wet sump	Standard-pressure	M248	PCE303.1017
GM Isuzu 3.1L 3.4L 6-Cylinder	t.	Standard-volume	Wet sump	Standard-pressure	M134	PCE303.1019
Mopar Chrysler SB 273 318 360	u.	Standard-volume	Wet sump	Standard-pressure	M72	PCE303.1006
	v.	High-volume			M72HV	PCE303.1007
Chrysler Dodge Plymouth 2.2L 2.5L 4-Cylinder	w.	Standard-volume	Wet sump	Standard-pressure	M118	PCE303.1022
Oldsmobile V8	x.	Standard-volume	Wet sump	Standard-pressure	M22F	PCE303.1023
AMC Jeep 2.5L 199 232 258	y.	Standard-volume	Wet sump	Standard-pressure	M81A	PCE303.1020

Oil Pump Driveshafts

Speedmaster™ oil pump driveshafts are machined from heat-treated chromoly steel and feature a larger diameter shaft than OE units for added torque capacity when using high-volume oil pumps. These Speedmaster™ oil pump driveshafts are sure to be the perfect choice for your next engine rebuild or replacement needs.



Application	Drive Gear Included	SKU
Chevrolet SBC 350	No	PCE301.1001
Chevrolet BBC 454	No	PCE301.1002
Ford 289 302W Windsor	No	PCE301.1003
Ford 351W Windsor	No	PCE301.1004
Ford 302 351C Cleveland	No	PCE301.1005
Ford Fe 390 427 428	No	PCE301.1006
Ford 429 460	No	PCE301.1007
Holden 304 308	Yes	PCE301.1008

Oil Pans, Individual

The oil pan serves as the reservoir for the engine's oil. It is designed to hold the amount of oil that is needed to lubricate the engine when it is running, plus a reserve. The oil pan helps to cool the oil thru its contact with the outside air. Dress up your oil system with an oil pan from Speedmaster™.



Oil Pans, Individual

Application	Ref.	Oil Pan Usage	Rear Main Seal Style	Dipstick Location	Sump Location	Max. Stroke w/ OE Rod	Sump Style	Capacity	Oil Pan Depth	Oil Pan Material	Oil Pan Finish	SKU	
Chevrolet SBC 350	a.	Stock	1-piece	US Passenger side	Rear	3.480 in.	Wet	4 quarts	7.000 in.	Steel	Chrome	PCE300.1049	
											Black painted	PCE300.1050	
											Natural	PCE300.1051	
									7.500 in.		Aluminum	Polished	PCE300.1030
												Polished Finned	PCE300.1031
	b.	Stock	2-piece	US Driver side	Rear	3.480 in.	Wet	4 quarts	7.500 in.	Steel	Chrome	PCE300.1028	
											Orange painted	PCE300.1029	
									7.250 in.		Aluminum	Polished Finned	PCE300.1027
	c.	Stock	2-piece	US Passenger side	Rear	3.480 in.	Wet	4 quarts	7.500 in.	Steel		Chrome	PCE300.1035
												Black painted	PCE300.1036
												Natural	PCE300.1037
	d.	Champion	2-piece	US Driver side	Rear	4.000 in.	Wet	7 quarts	7.000 in.	Steel	Black painted	PCE300.1017	
												Natural	PCE300.1018
												Zinc iridited	PCE300.1019
												Black painted	PCE300.1020
	e.	Circle Track	2-piece	US Driver side	Rear	4.000 in.	Wet	7 quarts	7.000 in.	Steel	Natural	PCE300.1021	
												Zinc iridited	PCE300.1022
	f.	Circle Track	2-piece	US Passenger side	Rear	4.000 in.	Wet	7 quarts	7.000 in.	Steel	Black painted	PCE300.1023	
												Natural	PCE300.1024
											Zinc iridited	PCE300.1025	
g.	Drag racing	1-piece	US Passenger side	Rear	3.800 in.	Wet	7 quarts	8.250 in.	Steel	Natural	PCE300.1052		
											Clear zinc	PCE300.1016	
i.	Drag racing	2-piece	US Driver side	Rear	3.800 in.	Wet	7 quarts	8.250 in.	Steel	Chrome	PCE300.1057		
											Orange painted	PCE300.1059	
											Zinc iridited	PCE300.1058	
j.	Drag racing	2-piece	US Passenger side	Rear	3.800 in.	Wet	7 quarts	8.250 in.	Steel	Chrome	PCE300.1064		
											Orange painted	PCE300.1065	
											Zinc iridited	PCE300.1066	
Chevrolet SB 350 (Suits HT-HK)	k.	Drag racing	2-piece	AU Passenger Side	Dual	3.800 in.	Wet	7 quarts	-	Steel	Black painted	PCE300.1074	
Chevrolet BBC 454 Gen IV	l.	Stock	2-piece	US Passenger side	Rear	-	Wet	4 quarts	7.750 in.	Steel	Chrome	PCE300.1038	
												Black painted	PCE300.1039
	m.	Drag racing	2-piece	US Passenger side	Rear	4.500 in.	Wet	6 quarts	8.250 in.	Steel	Natural	PCE300.1040	
												Chrome	PCE300.1061
												Orange painted	PCE300.1063
										Zinc iridited	PCE300.1062		
n.	Competition	2-piece	US Passenger side	Full	4.500 in.	Wet	10 quarts	8.500 in.	Steel	Black Painted	PCE300.1009		
											Orange painted	PCE300.1069	
											Black painted	PCE300.1014	
Chevrolet BBC 454 Gen V	p.	Drag racing	1-piece	US Passenger side	Rear	4.500 in.	Wet	6 quarts	8.250 in.	Steel	Black painted	PCE300.1071	
	q.	Drag racing	1-piece	US Passenger side	Rear	4.500 in.	Wet	7 quarts	8.500 in.		Zinc iridited	PCE300.1013	
Holden 304 308 (Suits HQ-WB)	r.	Stock	2-piece	AU Driver side	Rear	3.480 in.	Wet	4 quarts	-	Steel	Natural	PCE300.1075	
	s.	Drag racing	2-piece	AU Driver side	Rear	3.480 in.	Wet	7 quarts	-		Clear zinc	PCE300.1073	
Holden 304 308 (Suits VB-VT)	t.	Drag racing	2-piece	AU Passenger side	Front	3.480 in.	Wet	7 quarts	-	Steel	Zinc iridited	PCE300.1072	

Application	Ref.	Oil Pan Usage	Rear Main Seal Style	Dipstick Location	Sump Location	Maximum Stroke with OE Rod	Sump Style	Oil Pan Capacity	Oil Pan Depth (in)	Oil Pan Material	Oil Pan Finish	SKU	
Ford SB 289 302 Windsor 1965-87	aa.	Stock	1-piece, 2-piece	Timing Cover	Front	3.500 in.	Wet	5 quarts	7.750 in.	Steel	Chrome	PCE300.1032	
											Black painted	PCE300.1033	
											Natural	PCE300.1034	
									7.250 in.		Aluminum	Polished Finned	PCE300.1026
												Chrome	PCE300.1067
Ford SB 289 302 Windsor	ab.	Fox Body	1-piece, 2-piece	Timing Cover	Dual	3.400 in.	Wet	5 quarts	7.250 in.	Steel	Natural	PCE300.1068	
												Chrome	PCE300.1067
												Natural	PCE300.1068
												Chrome	PCE300.1067
Ford SB 289 302 Windsor	ac.	Drag racing	1-piece, 2-piece	Timing Cover	Front	3.500 in.	Wet	7 quarts	8.000 in.	Steel	Zinc iridited	PCE300.1011	
												Chrome	PCE300.1008
												Black painted	PCE300.1008
												Black painted	PCE300.1008
Ford 351W Windsor	ad.	Fox Body	1-piece, 2-piece	US Driver side	Dual	3.500 in.	Wet	7 quarts	8.250 in.	Steel	Zinc iridited	PCE300.1008	
												Chrome	PCE300.1008
	ae.	Stock	1-piece, 2-piece	Timing Cover	Front	3.500 in.	Wet	4 quarts	-	Steel	Chrome	PCE300.1055	
												Natural	PCE300.1056
	af.	Drag racing	1-piece, 2-piece	Timing Cover	Front	4.000 in.	Wet	7 quarts	8.000 in.	Steel	Zinc iridited	PCE300.1012	
												Chrome	PCE300.1012
												Natural	PCE300.1012
												Chrome	PCE300.1012
ag.	Fox Body	1-piece, 2-piece	US Driver side	Dual	4.100 in.	Wet	7 quarts	8.250 in.	Steel	Zinc iridited	PCE300.1010		
											Chrome	PCE300.1010	
ah.	Drag racing	1-piece	Timing Cover	Front	4.000 in.	Wet	7 quarts	8.000 in.	Aluminum	Natural	PCE300.1076		
											Chrome	PCE300.1041	
Ford 302 351C Cleveland	ai.	Stock	2-piece	Timing Cover	Front	4.100 in.	Wet	5 quarts	8.250 in.	Steel	Chrome	PCE300.1041	
												Natural	PCE300.1042
Ford Fe 390 427 428	aj.	Drag racing	2-piece	Timing Cover	Front	3.850 in.	Wet	7 quarts	8.000 in.	Steel	Natural	PCE300.1070	
												Chrome	PCE300.1045
Ford 429 460	al.	Stock	-	-	Front	4.500 in.	Wet	5 quarts	8.000 in.	Steel	Chrome	PCE300.1047	
												Natural	PCE300.1048
Mopar Chrysler BB 383 440	am.	Stock	2-piece	-	Center	3.750 in.	Wet	4 quarts	4.250 in.	Steel	Chrome	PCE300.1053	
												Natural	PCE300.1054
Mopar Chrysler SB 318 340 360	an.	Stock	2-piece	-	Center	4.125 in.	Wet	4 quarts	7.250 in.	Steel	Chrome	PCE300.1043	
												Natural	PCE300.1044
Oldsmobile 400 403 425 455	ao.	Road race	2-piece	US Passenger side	Rear	4.500 in.	Wet	7 quarts	8.250 in.	Steel	Zinc iridited	PCE300.1015	
Pontiac 326 400 455	ap.	Stock	2-piece	-	Rear	4.210 in.	Wet	4 quarts	7.000 in.	Steel	Chrome	PCE300.1046	
GM LS1 LS6	aq.	Fabricated	-	-	Front	4.125 in.	Wet	7 quarts	6.000 in.	Aluminum	Natural	PCE300.1077	
												Natural	PCE300.1078
	ar.				Rear								
Chrysler 426 Hemi KB BAE	as.	Drag racing	-	-	Full	-	Wet	-	7.000 in.	Aluminum	Natural	PCE300.1001	
												Natural	PCE300.1002
												Natural	PCE300.1003
Chrysler Hemi	at.	Funny Car	-	-	Full	-	Wet	-	5.250 in.	Aluminum	Natural	PCE300.1002	
												Natural	PCE300.1003
Rodeck Tfx	au.	Drag racing	-	-	Full	-	Dry	-	-	Aluminum	Natural	PCE300.1004	
												Natural	PCE300.1006
												Natural	PCE300.1006
												Natural	PCE300.1006

Oil Pan Fasteners

Speedmaster™ oil pan stud kits, which include heat-treated studs with rolled threads and special nuts with built-in serrated washer faces, are undoubtedly the best choice for attaching your Speedmaster™ pan. These kits provide easy pan installation and prolonged gasket life, and their special serrated nuts guard against pan loosening during operation. This universal kit includes four 5/16-18 in. and sixteen 1/4-20 in.



Fastener Style	Fastener Material	Fastener Finish	Fastener Nut Style	SKU
Stud	Steel	Black oxide	12-point	PCE299.1001

Engine Parts
Procomp Electronics
Air & Fuel Delivery
Traction Drive Systems
Turnkey Carburetor
Turnkey EFI
Turnkey Forced Induction
Crate Motors
Tools, Accessories & more

Oiling System

Oil Filters

Speedmaster™ oil filters feature a fully machined housing and an extra-fine, double mesh, stainless steel washable filter element. These are not only terrific filters for high-buck race engines, but they also add a touch of class and protection to street rods and street machines. Speedmaster™ oil filters are vastly superior to standard paper elements that have to be replaced every few thousand miles.

Features include:

- CNC-machined to provide exacting tolerances and fit
- Quad bypass filter design ensures that no unfiltered oil reaches the engine
- O-rings on all sealing joints
- Duplex-woven, deep-pleated, 45-micron stainless steel filter element
- Easy-maintenance cleanable S/S filter element
- Magnet in base to collect tiny particles



Application	Oil Filter Style	Filter Bypass Relief Valve	Anti-Drainback Valve	Smallest Particle Filtered	Thread Size	SKU
Universal	Canister	No	No	45 microns	1-12 in.	PCE298.1001

Oil Filter Covers

Available for both short and tall full size oil filters. These oil filter covers from Speedmaster™ slip over the filter and are held in place with a set screw.



Cover Material	Cover Finish	Diameter (in)	Length (in)	Installation	SKU
Steel	Chrome	3.687 in.	5.187 in.	Set screw	PCE297.1001
Steel	Chrome	3.687 in.	4.281 in.	Set screw	PCE297.1002

Oil Filter Adapters

Speedmaster™ Bolt-on bypass adapters are stock replacements designed to fit your engine block and accept an oil filter. These adapters are made with high-quality materials to create a durable product that you can depend on for years to come.

Speedmaster™ oil filter adapters allow you to connect the Speedmaster™ universal billet oil filter to your specific application.



Ref.	Application	Filter Adapter Style	Nipple Thread Size	Adapter Material	Adapter Finish	SKU
a.	Chevrolet SBC 350 1968-86	Bolt-on bypass adapter	13/16-16 in.	Aluminum	Natural	PCE296.1001
	Ford V8					PCE296.1003
b.	Chevrolet V8	To suit billet oil filter	-	Billet Aluminum	Clear anodized	PCE296.1004
	Holden V8					PCE296.1005

Engine Oil Dipsticks

Steel Handle

Replace your bent or rusty dipstick and tube with one of Speedmaster™ engine oil dipstick and tube kits. Dress up your engine with these chrome-plated kits which feature stock, OEM replacement designs. They're made from quality steel, with durable chrome plating for good corrosion protection and long life.

Billet Handle

Speedmaster™ billet handle engine oil dipsticks make checking your engine oil easy. They feature a chrome plated dipstick and tube that uses a fully polished billet aluminum handle. Speedmaster™ billet handle engine oil dipsticks will add some style to your engine compartment, while giving accurate measurements on your oil capacity.

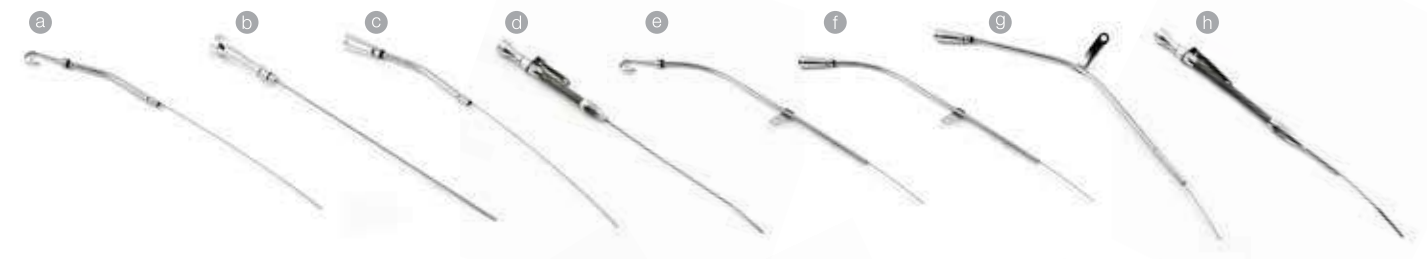

Application	Ref.	Dipstick Entry	Dipstick Handle Material	Dipstick Handle Finish	Dipstick Tube Included	Dipstick Tube Material	Dipstick Tube Finish	SKU
Chevrolet SBC 350 1955-79	a.	Engine block	Steel	Chrome	Yes	Steel	Chrome	PCE295.1001
	b.		Billet aluminum	Polished	No	-	-	PCE295.1003
	c.		Billet aluminum	Polished	Yes	Steel	Chrome	PCE295.1004
	d.		Billet aluminum	Natural	Yes	Braided stainless steel	Natural	PCE295.1017
Chevrolet SBC 350 1980-82	e.	Engine block	Steel	Chrome	Yes	Steel	Chrome	PCE295.1015
	f.		Billet aluminum	Polished	Yes	Steel	Chrome	PCE295.1009
Chevrolet SBC 350 1982-85	g.	Engine block	Billet aluminum	Polished	Yes	Steel	Chrome	PCE295.1010
Chevrolet SBC 350 1980-85	h.	Oil pan	Billet aluminum	Chrome	Yes	Braided stainless steel	Natural	PCE295.1016
Chevrolet BBC 454 1966-90	i.	Oil pan	Steel	Chrome	Yes	Steel	Chrome	PCE295.1002
	j.		Billet aluminum	Polished	Yes	Steel	Chrome	PCE295.1005
	k.		Billet aluminum	Polished	Yes	Braided stainless steel	Natural	PCE295.1018
Ford SB 289 302 351 Windsor (351W up to 85)	l.	Timing cover	Steel	Chrome	Yes	Steel	Chrome	PCE295.1013
	m.		Billet aluminum	Polished	Yes	Steel	Chrome	PCE295.1006
Ford 302 351C Cleveland	n.	Timing cover	Steel	Chrome	Yes	Steel	Chrome	PCE295.1014
Mopar Chrysler SB 318 340 360	o.	Engine block	Billet aluminum	Polished	Yes	Steel	Chrome	PCE295.1007
Mopar Chrysler BB 383 440	p.	Engine block	Billet aluminum	Polished	Yes	Steel	Chrome	PCE295.1008
Oldsmobile 350-455 Pontiac 389 403	q.	Engine block	Billet aluminum	Polished	Yes	Steel	Chrome	PCE295.1011
Pontiac 287-455 1965-79 (Not 389 403)	r.	Engine block	Billet aluminum	Polished	Yes	Steel	Chrome	PCE295.1012

Oiling System

Crankcase Evacuation Systems

Speedmaster™ crankcase evacuation systems are primarily drag race systems designed to reduce pressure buildup in the engine crankcase. They provide better piston ring seal, less intake charge contamination, and a reduced chance of oil leaks, while increasing your engine performance.

* Cannot be used on vehicles with mufflers.



Application	Breather Material	Breather Finish	Check Valve Material	Check Valve Finish	Evacuation Hose Included	Weld-In Nipples for Header Included	Valve Cover Grommet Material	SKU
Universal	Steel	Chrome	Steel	Gold Iridited	No	Yes	Rubber	PCE293.1001

Oil Filter Mounts

Use these quality oil filter mounts from Speedmaster™ to relocate your oil filter. Machined from billet aluminum, these remote mounts are especially useful in high performance vehicles where quick, easy access to an oil filter is desired.



Ref.	Inlet Quantity	Inlet Attachment	Outlet Quantity	Outlet Attachment	Oil Filter Bracket Material	Oil Filter Bracket Finish	SKU
a.	One	Female threads	One	Female threads	Billet Aluminum	Black anodized	PCE507.1001
b.	Two	Female threads	Two	Female threads	Billet Aluminum	Black anodized	PCE507.1002

Oil Restrictors

When roller rocker arms are installed, along with a mechanical lifter cam, the amount of oil flow required to the valvetrain is greatly reduced. Installing a Speedmaster™ oil restrictor kit will limit this unnecessary oil flow. These kits reduce the power-robbing windage created from the excess oil draining past the rotating assembly and keeps the oil flowing where it is needed most, the rod and main bearings.



Application	Orifice Size	Thread Size	Quantity	SKU
Ford 302 351C Cleveland	.0600 in.	5/16 in.	Set of 5	PCE304.1001
Chevrolet SBC 350	.0625 in.	1/4 in. NPT	Pair	PCE304.1002

Oil Pump Pickups

Speedmaster™ oil pump pickups are specially matched to our Speedmaster™ oil pans. They are engineered to be "where the oil is" under the most demanding racing conditions. Precision-bent and heliarc welded from high quality steel, these pickups help keep your motor bathed with a healthy supply of oil. A wire mesh steel screen, which is welded to the pickup box, traps debris without restricting oil flow.

Note: They can be used for Standard application Pumps.



Application	Ref.	Oil Pan Style	Oil Pump Style	SKU
Chevrolet SBC 350	a.	Champion	5 Bolt Pump	PCE302.1002
	b.	Circle Track	Std Pump	PCE302.1003
	c.	Circle Track	HV Pump	PCE302.1004
	d.	Circle Track	Std Pump	PCE302.1007
	e.	Drag race	4 Bolt Pump	PCE302.1001
	f.	Drag race - 4" Stroke PCE300.1016	-	PCE302.1014
	g.	Drag race PCE300.1057-59	-	PCE302.1017
Chevrolet BBC 454 Gen IV	h.	Competition	4 Bolt Pump	PCE302.1006
Chevrolet BBC 454 Gen V	i.	Drag race	4 Bolt Pump	PCE302.1005
Chevrolet BBC 454 Gen V	j.	Drag Pan Deep Sump	-	PCE302.1016
Holden 304 308 (Suits HQ-WB)	k.	Rear Hump	-	PCE302.1008
GM LS1 LS6	-	Drag race - Front Sump PCE300.1077	-	PCE302.1010
	-	Drag race - Rear Sump PCE300.1078	-	PCE302.1011
Ford SB 289 302 Windsor	-	Fox Body PCE300.1008	-	PCE302.1015
Ford 351W Windsor	l.	Fabricated - Drag Race PCE300.1076	-	PCE302.1009
	m.	Fox Body PCE300.1010	-	PCE302.1012
Oldsmobile 400 403 425 455	-	Road Race PCE300.1015	-	PCE302.1013

Gaskets & Seals

Engine Gasket Sets

Speedmaster™ offers gaskets for all of the popular applications. From valve covers and carburettor base gaskets to full engine gasket sets. These Speedmaster™ gasket kit sets include premium-quality head gaskets, intake gaskets, exhaust gaskets, valve cover gaskets, oil pan gaskets, valve stem seals, and all accessory gaskets--everything that you need for a complete engine rebuild, all in one affordable set. If it has to seal right the first time Speedmaster™ has what you need.



Application	Notes	SKU
Chevrolet 400 1955-79	Multi Layered Steel	PCE347.1012
Chevrolet BBC 454 1966-79	-	PCE347.1009
Chevrolet SBC 327 350 383 400	-	PCE347.1006
Chevrolet SBC 350 1955-79	Multi Layered Steel	PCE347.1013
Ford 289 302 1963-82 Windsor	-	PCE347.1001
	Multi Layered Steel	PCE347.1003
Ford 302 351C 351M 400 Cleveland 1970-82	-	PCE347.1007
	Multi Layered Steel	PCE347.1014
Ford 351W Windsor 1969-74	2 Pcs RMS	PCE347.1008
	No Head Gaskets	PCE347.1019
	Multi Layered Steel (4.050 Bore)	PCE347.1020
GM LS1 LS6 1997-2005	Multi Layered Steel (4.106 Bore)	PCE347.1021
	Multi Layered Steel (4.160 Bore)	PCE347.1022
	Multi Layered Steel (3.945 Bore)	PCE347.1023
Holden 253 308 (NEO RMS)	-	PCE347.1026
	Multi Layered Steel	PCE347.1030
Holden 253 308 (ROPE RMS)	-	PCE347.1027
	Multi Layered Steel	PCE347.1031
Holden 304 EFI (NEO RMS)	-	PCE347.1024
	Multi Layered Steel	PCE347.1028
Holden 304 EFI (ROPE RMS)	-	PCE347.1025
	Multi Layered Steel	PCE347.1029

Head Gaskets

Speedmaster™ head gaskets are proven to handle big power any way you can make it. Speedmaster™ gaskets are designed to maintain contact pressure between the cylinder head and block during the dynamics of engine operation. Speedmaster™ MLS gaskets use a high pressure steel laminate design known for standing up against the extremely high shearing forces that occur between an aluminum head and iron block. It's internal embossments expand heat to create a better seal when the engine is seeing extremely high combustion pressures and temperatures as is the case with heavy nitrous and turbocharged applications. MLS (Multi Layer Steel) is ideal for both aluminum heads to cast iron blocks and aluminum heads to aluminum blocks. These gaskets offer better torque retention, less distortion, and better sealing than conventional or composite head gaskets in high-horsepower, high cylinder-pressure applications.



Application	Bore (in)	Quantity	SKU
Chevrolet 400	4.100 in.	Single	PCE348.1006
		Pair	PCE348.1013
Chevrolet 5.3L	3.945 in.	Single - Left	PCE348.1014
		Single Right	PCE348.1015
Chevrolet BBC 454	4.380 in.	Single	PCE348.1009
	4.585 in.	Single	PCE348.1004
	4.065 in.	Single	PCE348.1003
Chevrolet SBC 350	4.100 in.	Single	PCE348.1010
	4.165 in.	Single	PCE348.1011
	4.185 in.	Single	PCE348.1012
Ford 289 302 351 Windsor	4.065 in.	Single	PCE348.1007
Ford 351W Windsor	4.185 in.	Single	PCE348.1008
Ford 302 351C Cleveland	4.065 in.	Single	PCE348.1005
		Pair	PCE348.1016
	4.050 in.	Single - Left	PCE348.1017
		Single Right	PCE348.1018
		Pair	PCE348.1019
GM LSX	4.106 in.	Single - Left	PCE348.1020
		Single Right	PCE348.1021
		Pair	PCE348.1022
	4.160 in.	Single - Left	PCE348.1023
		Single Right	PCE348.1024
		Pair	PCE348.1033
	4.200 in.	Single - Left	PCE348.1025
		Single Right	PCE348.1026
Holden 253 304 308	4.065 in.	Pair	PCE348.1027

Intake Manifold Gaskets

Most Speedmaster™ intake manifold gaskets have Printoseal construction, which puts beads of special elastomers around the ports for extra sealing power. They also feature a non-metallic, rubber-fiber base material that resists gasoline and alcohol, while allowing engine builders to precision-trim around the intake ports.



Application	Port Style	Port Height	Port Width	SKU
		2.210 in.	1.310 in.	PCE349.1002
Chevrolet SBC 350	Rectangular	2.090 in.	1.280 in.	PCE349.1003
		2.280 in.	1.380 in.	PCE349.1005
		2.210 in.	1.310 in.	PCE349.1012
Chevrolet SBC 350 Vortec	Stock	2.110 in.	1.080 in.	PCE349.1004
Chevrolet BBC 454	Rectangular	2.540 in.	1.820 in.	PCE349.1007
	Oval	2.050 in.	1.820 in.	PCE349.1008
Ford 289 302 Windsor	Rectangular	2.250 in.	1.400 in.	PCE349.1006
Ford 302 351C 351M 400 Cleveland 2V & 3V	Stock	-	-	PCE349.1013
Ford 302 351C Cleveland 3V	Stock	-	-	PCE349.1001
Ford 351C 2V	Stock	-	-	PCE349.1022
Ford 351C 4V	Stock	-	-	PCE349.1018
Ford 429 460	Round port	2.260 in.	1.980 in.	PCE349.1009
GM LS1 LS6	Cathedral	3.340 in.	1.190 in.	PCE349.1019
GM LS3 L92 6.2L	Rectangular	2.700 in.	1.350 in.	PCE349.1020
GM LS7 7.0L	Rectangular	2.450 in.	1.450 in.	PCE349.1021
Holden 253 308	Stock	-	-	PCE349.1014
Holden 304	Stock	-	-	PCE349.1016
Mopar Chrysler BB 383 440	Rectangular	2.710 in.	1.165 in.	PCE349.1023
Mopar Chrysler SB 318 340 360	Rectangular	2.270 in.	1.160 in.	PCE349.1010
Oldsmobile 400 425 455	Stock	2.400 in.	1.400 in.	PCE349.1011

Oil Pan Gaskets

Rubber

Speedmaster™ gaskets are designed for today's performance engines, which can create excessive amounts of vacuum and pressure in the oil pan. They're constructed from a cellulose/nitrile material that features excellent tensile strength and superior blowout resistance, and their latex coating conforms to minor sealing-surface irregularities for a better seal.



Cork

Speedmaster™ manufactures oil pan gaskets that are ideal for the street or strip. These gaskets meet or exceed OEM specs and are proven for racing applications as well. Speedmaster oil pan gaskets are precision-cut from cork providing an accurate size and shape for the appropriate oil pan.



Application	Gasket Material	RMSI Style	One-Piece	SKU
Chevrolet SBC 350 1955-79	Cork	2-piece	No - 4 Pc	PCE350.1015
	Rubber		Yes	PCE350.1002
Chevrolet SBC 350 1980-85	Rubber	2-piece	Yes	PCE350.1003
	Cork		No - 4 Pc	PCE350.1016
Chevrolet SBC 350 1986-97	Rubber	1-piece	Yes	PCE350.1004
Chevrolet BBC 454 1966-90	Rubber	2-piece	Yes	PCE350.1005
	Cork		No - 4 Pc	PCE350.1021
	Rubber		Yes	PCE350.1006
Chevrolet BBC 454 1991-00	Rubber - Marine	1-piece	Yes	PCE350.1007
Ford SB 289 302 Windsor	Rubber		Yes	PCE350.1010
	Cork		No - 4 Pc	PCE350.1008
Ford 351W Windsor	Rubber		Yes	PCE350.1011
	Cork		No - 4 Pc	PCE350.1009
Ford 302 351C Cleveland	Cork		No - 4 Pc	PCE350.1012
Holden 253 304 308	Rubber		Yes	PCE350.1013
	Cork		No - 4 Pc	PCE350.1014

Headers

-Backpressure +Horsepower

Headers are one of the easiest bolt-on accessories you can use to improve an engine's performance. The goal of headers is to make it easier for the engine to push exhaust gases out of the cylinders. The idea behind an exhaust header is to eliminate the manifold's back pressure. Instead of a common manifold that all of the cylinders share, each cylinder gets its own exhaust pipe. These pipes come together in a larger pipe called the collector. The individual pipes are cut and bent so that each one is the same length as the others. By making them the same length, it guarantees that each cylinder's exhaust gases arrive in the collector spaced out equally so there is no back pressure generated by the cylinders sharing the collector. The individual pipes are cut and bent so that each one is the same length as the others. By making them the same length, it guarantees that each cylinder's exhaust gases arrive in the collector spaced out equally so there is no back pressure generated by the cylinders sharing the collector.

Eliminate back-pressure and increase horsepower with Speedmaster's finest selection of air-pushing, muscle-pumping performance exhaust headers for your engine. Available in a variety of different coatings for different thermal properties as well as appearance.



Quick Tip



Mandrel Bent

Why you want Mandrel Bent Exhaust The results are smooth, uniform, constant-diameter bends that greatly reduce restriction and improve both the performance and efficiency of your engine.

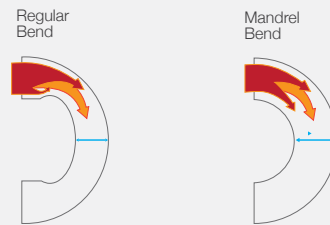

Because we know Appearance does Matter

Speedmaster™ Headers are Available in five different finishes for the look you want.



Exhaust Header Gaskets

Complete engine sealing with Speedmaster™ exhaust gaskets. Properly sealing an engine is paramount to making maximum horsepower. Speedmaster™ exhaust manifold gaskets are designed to give your manifold and headers an exact seal with their high quality construction.



Application	Gasket Material	SKU
Chevy SBC 283 400	High-temperature Fiber	PCE355.1014
Chevy SBC 350 Round	Cooper	PCE355.1004
Chevy SBC 350 Oval	Cooper	PCE355.1005
Chevy SBC 350	Composite	PCE355.1012
Chevy BBC 454	Cooper	PCE355.1003
	Composite	PCE355.1011
Ford SB 289 302 351 Windsor	Cooper	PCE355.1002
	High-temperature Fiber	PCE355.1007
Ford 302 351C Cleveland 2V	Composite	PCE355.1006
Ford 302 351C Cleveland 4V	High-temperature Fiber	PCE355.1010
Ford 429 460	Composite	PCE355.1009
Holden 253 308 Early	Composite	PCE355.1008
Holden 253 308 Late	Composite	PCE355.1013
Chrysler Mopar Small Block 273 318 360	High-temperature Fiber	PCE355.1015
Oldsmobile Olds 260-455 V8	High-temperature Fiber	PCE355.1001

Header Fasteners

Speedmaster™ manufactures a variety of header bolts to facilitate the installation of your headers. Rated at 170,000 psi, they're much stronger than stock and will last under even the most severe conditions. Each kit includes the specific number of parts required for the desired application, plus premium-quality washers and either hex or 12-point heads.



Application	Fastener Material	Fastener Finish	Head Style	Thread Size	Underhead Length (mm)	Quantity	SKU
Chevrolet SBC 350	Steel	Black Oxide	12 Point	3/8-16 in	19.00mm	Set of 12	PCE317.1002
	Stainless Steel	Polished	Hex		29.00mm		PCE317.1004
Chevrolet BBC 454	Steel	Black Oxide	12 Point	3/8-16 in	19.00mm	Set of 16	PCE317.1003
	Steel	Black Oxide	12 Point		M10-1.5 x 3/8-16 in		45.00mm

Headers

Engine	Application	Notes	Finish	SKU	
Chevrolet 5.3L	Suburban Tahoe Yukon 1999-05	1999-05	Stainless Steel	PCE316.1105	
Chevrolet 6-Cylinder 216 235 261	Universal	1935-62	Stainless Steel	PCE316.1098	
	1955-57 Chassis	-	Stainless Steel	PCE316.1089	
	1965-89 Chassis	1 5/8" to 2"	Stainless Steel	PCE316.1079	
	1982-92 Camaro Firebird F Body Dual Turbo	-	Stainless Steel	PCE316.1110	
	Camaro Firebird	-	Stainless Steel	PCE316.1017	
	Camaro Firebird 1993-97	-	Stainless Steel	PCE316.1104	
	Chevelle Camaro 1967-81			Black Painted	PCE316.1019
				Ceramic	PCE316.1021
				Chrome	PCE316.1018
				Raw	PCE316.1020
				Stainless Steel	PCE316.1022
	Chevelle Camaro Bel Air Competition 1965-89	-	Raw	PCE316.1078	
	Chevy Malibu Monte Carlo 1972-87	-	Black Painted	PCE316.1106	
	Classic T-Bucket			Raw	PCE316.1096
				Stainless Steel	PCE316.1097
	Corvette 1962-63 Rams Horn w/2.5" CD	-	Raw	PCE316.1016	
	Fat Fenderwell 1935-48	-	Stainless Steel	PCE316.1091	
	Fenderwell Roadster Street Rod 1935-48	-	Raw	PCE316.1090	
	Holden HK HT HG	Tuned	Silver Painted	PCE316.1073	
	Holden HQ HJ HX HZ WB	Tuned Competition	Silver Painted	PCE316.1077	
	IMCA			Black Painted	PCE316.1100
				Stainless Steel	PCE316.1086
	Chevrolet SBC 350			Raw	PCE316.1099
			Black Painted	PCE316.1024	
Pickup 1988-95			Chrome	PCE316.1023	
			Raw	PCE316.1026	
			Stainless Steel	PCE316.1027	
			Ceramic	PCE316.1025	
			Black Painted	PCE316.1107	
Pickup Truck 1973-85	-	Raw	PCE316.1074		
Street Rod Hi-Boy 1932	-	Raw	PCE316.1094		
Truck Pick Up 1966-1987			Stainless Steel	PCE316.1095	
			Ceramic	PCE316.1109	
Universal			Stainless Steel	PCE316.1043	
			Black Painted	PCE316.1008	
			Ceramic	PCE316.1009	
		1 5/8" Block Hugger	Chrome	PCE316.1006	
			Raw	PCE316.1013	
			Stainless Steel	PCE316.1011	
			Black Painted	PCE316.1039	
Universal		1 5/8" Block Hugger (Angle Plug Heads)	Ceramic	PCE316.1040	
			Raw	PCE316.1041	
Universal			Stainless Steel	PCE316.1042	
		1 5/8" Block Hugger w/ S/S Flange	Stainless Steel	PCE316.1007	
Universal 1955-57	1.5" Block Hugger	Stainless Steel	PCE316.1030		
Universal 1955-57			Stainless Steel	PCE316.1029	
		1.5" Block Hugger (Straight Plug Heads)	Ceramic	PCE316.1031	
1965-1975 Chevelle Camaro Bel Air			Black Painted	PCE316.1028	
			Raw	PCE316.1082	
Chevrolet BBC 454			Stainless Steel	PCE316.1083	
			Black Painted	PCE316.1066	
			Ceramic	PCE316.1120	
		Camaro With A/C 1967-69	-	Chrome	PCE316.1065

Engine	Application	Notes	Finish	SKU	
Chevrolet BBC 454	Chevelle Camaro	-	Ceramic	PCE316.1046	
			Raw	PCE316.1045	
			Stainless Steel	PCE316.1047	
	Chevelle Camaro GM A Body	-	Chrome	PCE316.1111	
	Hot Rod Street Rod Center Dump	Block Hugger	Chrome	PCE316.1121	
	Universal		Block Hugger	Ceramic	PCE316.1049
				Raw	PCE316.1048
				Stainless Steel	PCE316.1050
	GM LS1 LS2	Holden Commodore VT VX VY VZ Monaro	Tuned Competition	Silver Painted	PCE316.1069
		Truck Cadillac Chevy Hummer Pickup	-	Stainless Steel	PCE316.1058
GM LS1 LS6	Universal	Block Hugger	Ceramic	PCE316.1060	
			Raw	PCE316.1059	
			Stainless Steel	PCE316.1061	
GM LS3	Camaro 2010-11 T304 02 Sensor Insertion	-	Stainless Steel	PCE316.1067	
GM LS3 L99	Camaro 2010-14	Shorty Tuned	Stainless Steel	PCE316.1057	
GM LSX LS2 LS3 LS6 LS7	Chevelle Camaro	Shorty	Stainless Steel	PCE316.1062	
Holden 3.6L V6 Alloytec	Holden Commodore VE	Tuned	Silver Painted	PCE316.1076	
Holden 3.8L V6 Supercharged	Holden Commodore Monaro VT VX VU VY	Tuned	Silver Painted	PCE316.1075	
Holden 253 308	Holden Commodore VB VC VH VK	Tri-Y Competition	Silver Painted	PCE316.1070	
	Holden HQ HJ HX HZ WB Turbo 400	Tuned	Silver Painted	PCE316.1071	
Ford 2.3L/140	Pinto (F235V)	-	Stainless Steel	PCE316.1092	
	Pinto (F239V)	-	Stainless Steel	PCE316.1093	
Ford 5.0L	Ford Mustang 2011-2013	Long Tube	Raw	PCE316.1101	
			Stainless Steel	PCE316.1103	
			Black Painted	PCE316.1102	
Ford SB 289 302 351 Windsor	1927-34 Chassis	-	Raw	PCE316.1087	
			Stainless Steel	PCE316.1088	
	Mustang 1964-70	Tri-Y to	Stainless Steel	PCE316.1051	
			Ceramic	PCE316.1052	
	Mustang 1964-70	Tri-Y Short	Stainless Steel	PCE316.1044	
			Black Painted	PCE316.1002	
			Chrome	PCE316.1001	
			Raw	PCE316.1004	
			Stainless Steel	PCE316.1003	
			Ceramic	PCE316.1005	
Sprint Roadster Street Rod			Raw	PCE316.1080	
			Stainless Steel	PCE316.1081	
			Ceramic	PCE316.1055	
			Raw	PCE316.1054	
			Stainless Steel	PCE316.1056	
			Stainless Steel	PCE316.1035	
			Stainless Steel	PCE316.1063	
Mopar Chrysler SB 318 340 360	Universal	Block Hugger	Stainless Steel	PCE316.1064	
		Block Hugger w/Reducers	Stainless Steel	PCE316.1068	
Chrysler Hemi 331 392	Universal	1 3/4" Tubing Block Hugger	Ceramic	PCE316.1118	
			Stainless Steel	PCE316.1032	
			Chrome	PCE316.1119	
Oldsmobile 330 350	Trans Am		Ceramic	PCE316.1038	
			Raw	PCE316.1036	
			Stainless Steel	PCE316.1037	
Cadillac 425 472 500	Universal	Block Hugger	Stainless Steel	PCE316.1108	
			Stainless Steel	PCE316.1033	
Jeep AMC 4.0L	Cherokee 1991-99		Stainless Steel	PCE316.1034	
			Cherokee 2000-06	-	Stainless Steel

Radiators

Extreme Cooling

When time is crucial and weight means everything, let a Speedmaster™ aluminum Competition series radiator give your street, strip or high-powered show car the advantage. Manufactured with lightweight aluminum technology, these radiators are designed in a wide variety of racing sizes for your cooling needs. The Speedmaster™ design incorporates open-fin spacing that promotes airflow through the radiator to enhance the cooling and help eliminate clogging.

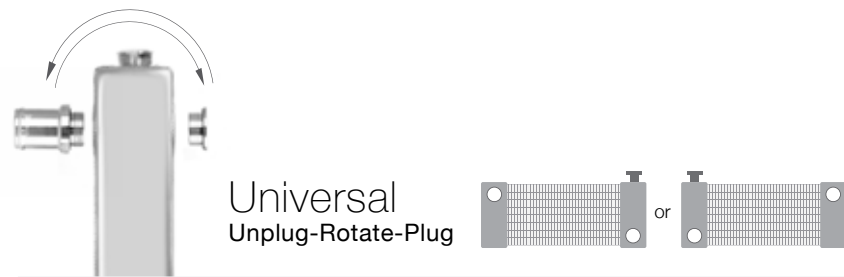

Inlet Location	Outlet Location	Radiator Finish	Drain Plug	Overall Thickness (in)	Overall Height (in)	Overall Width (in)	SKU
Both	Both	Polished	No	2.200 in.	20.200 in.	20.000 in.	PCE190.1058
						21.000 in.	PCE190.1040
						22.000 in.	PCE190.1041
						24.000 in.	PCE190.1042
						25.000 in.	PCE190.1043
						26.000 in.	PCE190.1044
						27.000 in.	PCE190.1045
						28.000 in.	PCE190.1046
						29.000 in.	PCE190.1047
						31.000 in.	PCE190.1048

Quick Tip

The coolant flows from the inlet to the outlet through many tubes mounted in a parallel arrangement. The fins conduct the heat from the tubes and transfer it to the air flowing through the radiator.

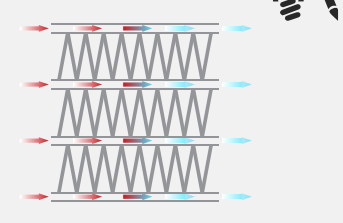

Chevrolet GM

Inlet Location	Outlet Location	Radiator Finish	Drain Plug	Overall Thickness (in)	Overall Height (in)	Overall Width (in)	SKU
Top Left	Bottom Right	Polished	No	2.200 in.	20.200 in.	21.000 in.	PCE190.1001
						22.000 in.	PCE190.1002
						24.000 in.	PCE190.1003
						25.000 in.	PCE190.1004
						26.000 in.	PCE190.1005
						27.000 in.	PCE190.1006
						28.000 in.	PCE190.1007
						29.000 in.	PCE190.1008
						31.000 in.	PCE190.1009
						Top Left	Bottom Right
22.000 in.	PCE190.1010						
24.000 in.	PCE190.1011						
25.000 in.	PCE190.1012						
26.000 in.	PCE190.1013						
27.000 in.	PCE190.1014						
28.000 in.	PCE190.1015						
29.000 in.	PCE190.1016						
31.000 in.	PCE190.1017						
Top Left	Bottom Right	Natural	No	2.200 in.	20.200 in.		
						28.000 in.	PCE190.1018
						30.000 in.	PCE190.1019
						32.000 in.	PCE190.1020
						34.000 in.	PCE190.1021
						37.000 in.	PCE190.1022

Ford Mopar

Inlet Location	Outlet Location	Radiator Finish	Drain Plug	Overall Thickness (in)	Overall Height (in)	Overall Width (in)	SKU
Top Right	Bottom Left	Polished	No	2.200 in.	20.200 in.	21.000 in.	PCE190.1023
						22.000 in.	PCE190.1024
						24.000 in.	PCE190.1025
						25.000 in.	PCE190.1026
						26.000 in.	PCE190.1027
						27.000 in.	PCE190.1028
						27.500 in.	PCE190.1029
						28.000 in.	PCE190.1030
						29.000 in.	PCE190.1031
						31.000 in.	PCE190.1032
Top Right	Bottom Left	Natural	Yes	2.200 in.	20.200 in.	24.000 in.	PCE190.1033
						26.000 in.	PCE190.1034
						28.000 in.	PCE190.1035
						31.000 in.	PCE190.1036
						26.000 in.	PCE190.1049
						28.000 in.	PCE190.1050
Top Right	Bottom Left	Natural	No	2.200 in.	20.200 in.	31.000 in.	PCE190.1051
						29.000 in.	PCE190.1052

Radiators

Downflow



Downflow w/ Fan



Radiator Supports

Speedmaster™ chrome, heavy-gauge steel radiator supports are exact replacements for your factory support. They include all hardware for quick and easy installation.



- a. PCE190.1037 Ford Roadster High Boy 1933-34 (Tall)
- b. PCE190.1038 Ford Roadster High Boy 1932 (Short)
- c. PCE190.1055 60-66 Ford/Mercury Sbc/Mustang 3.3L L6/V8 & 14" Electric Fan
- d. PCE190.1056 01-05 Civic Ex/Lx/Si Ep3 Em2 Es Mt & 2 X 10" Electric Fan
- e. PCE190.1057 Civic/Del Sol/Integra Dc & 12" Electric Fan
- f. PCE189.1002 Chevy Camaro 1970-81 Standard
- g. PCE189.1003 Chevy Chevelle Nova

Fluid Coolers Transmission Oil

Dual Outlet Heat sink

The key to a cooler and longer-lasting transmission is simple Speedmaster™ dual transmission coolers! These dual transmission coolers provide a sleek, compact alternative to bulky transmission coolers. They feature aluminum construction and provide great cooling rate due to the double outlet design. This allows for an efficient fluid transfer, thus reducing the transmission temperatures for optimum performance. Features 1/4 in. NPT inlet and outlet Female threads. This cooler includes two 1/4 in. NPT x 3/8 in. hose barb fittings.



Single Outlet Heat sink

The internal and external cooling fins in these Speedmaster™ heat sink transmission coolers provide maximum cooling efficiency without relying on direct airflow. Their compact diameter means that they can be mounted in a variety of locations, such as on the frame rail next to the transmission, directly under the radiator, under the floorboards, etc. Their rugged aluminum extrusion features welded ends for long service life, in even the toughest environments. Features 3/8 in. NPT inlet and outlet Female threads. Includes 3/8 in. hose barb fittings.



Flat Tube & Fin

Speedmaster™ transmission oil coolers feature a new tubular design that improves heat transfer dramatically over other designs. It can drop your transmission fluid temperature 20 degrees, and that can double the life of your automatic transmission. You'll get longer life and more consistent shifts even while doing heavy-duty towing. All necessary fittings come included with the kit. Features 3/8 in. hose barb inlet and outlet attachment.



Fluid Coolers with Fan

Speedmaster™ remote fluid coolers combine a high-capacity oil-cooler core with a 10-inch electric fan for maximum cooling in any environment. This superior combination will give you the peace of mind knowing that your fluids will be at their prime operating temperatures. These coolers feature high flow tubes and aluminum dissipating fins with plastic edge-guard protectors, all with a durable black powdercoat finish.

Each fan is solidly mounted to the cooler core with clear-anodized billet-aluminum brackets to ensure a stable attachment. You can make these coolers even better with the fan thermostats and installation kits that are sold separately.



Overall Height (in)	Overall Width (in)	Overall Thickness (in)	Cooler Finish	Maximum Fan CFM	Fan Diameter (in)	Inlet Size	Inlet Attachment	Outlet Size	Outlet Attachment	Number of Cooling Rows	SKU
11.500 in.	12.500 in.	5.000 in.	Black painted	650 cfm	10.000 in.	-6 AN	Male threads	-6 AN	Male threads	16	PCE187.1001

- a. PCE186.1018 10" Dual Pass Silver Anodized
- PCE186.1019 12" Red Anodized
- PCE186.1020 15" Blue Anodized
- PCE186.1021 18"
- PCE186.1022 20"
- PCE186.1023 22"
- b. PCE186.1004 15" Single Pass Silver Anodized
- PCE186.1005 Red Anodized
- PCE186.1006 Blue Anodized
- b. PCE186.1007 18" Single Pass Silver Anodized
- PCE186.1008 Red Anodized
- PCE186.1009 Blue Anodized
- b. PCE186.1010 20" Single Pass Silver Anodized
- PCE186.1011 Red Anodized
- PCE186.1012 Blue Anodized
- b. PCE186.1013 22" Single Pass Silver Anodized
- PCE186.1014 Red Anodized
- PCE186.1015 Blue Anodized
- c. PCE186.1016 7.5" H x 15.5" W 6-Rows Tube and fin
- PCE186.1017 10" H x 15.5" 8-Rows

Fans, Electric

Speedmaster™ high performance reversible electric cooling fans are ideal for high performance or OEM applications. Configured as a puller from the factory, it mounts on the inside and pulls the air through the radiator. Blades and polarity of the wiring can be reversed and it becomes a pusher mounted pushing air through the radiator. These fans will keep your engine cooler at lower driving speeds. Speedmaster™ reversible fans ride on dual ball bearings instead of bushings, which means higher efficiency and less heat. They also free up more usable horsepower to the rear wheels, and increases fuel economy.

a Straight Blades



b S-Blades



Noise

A curved blade cut into the air less than a straight blade. This creates less noise, so curved-blade fans are usually much quieter than a fan with straight blades.

Performance

Although curved blades are quieter, the reduction in noise comes at a price. Curved blades move less air than straight blades, creating a less powerful breeze than a traditional straight blade.

Choice

If you are easily bothered by fan noise, then a curved-blade fan should appeal to you because it is quieter. But if you want maximum performance out of a fan, a straight-blade fan is probably the way to go, even if it is a little louder.

Ref.	Blade Shape	Fan Diameter (in)	Height (in)	Width (in)	Thickness (in)	Number of Blades	Maximum Fan CFM	Maximum Fan RPM	Amp Draw	Shroud Color	SKU	
a.	Curved	8.000 in.	8.500 in.	8.875 in.	2.500 in.	10 blades	550 cfm	2,180 rpm	6.80 amps	Black	PCE185.1018	
		9.000 in.	9.750 in.	10.250 in.	2.500 in.	10 blades	720 cfm	2,180 rpm	6.80 amps	Black	PCE185.1004	
		10.000 in.	11.000 in.	11.250 in.	2.500 in.	6 blades	775 cfm	2,180 rpm	6.80 amps	Black	PCE185.1003	
		12.000 in.	12.500 in.	12.875 in.	3.375 in.	6 blades	1,007 cfm	2,250 rpm	6.80 amps	Black	PCE185.1006	
		14.000 in.	14.500 in.	14.875 in.	3.500 in.	8 blades	1,440 cfm	1,945 rpm	7.90 amps	Black	PCE185.1008	
					3.500 in.			2,010 cfm	2,270 rpm	8.50 amps	Black	PCE185.1013
					(BM) 4.500 in.		10 blades	2,330 cfm	2,850 rpm	10.50 amps	Black	PCE185.1014
					3.500 in.			2,010 cfm	2,270 rpm	8.50 amps	Chrome	PCE185.1015
					(BM) 4.500 in.			2,330 cfm	2,850 rpm	10.50 amps	Chrome	PCE185.1016
		b.	Straight	8.000 in.	8.500 in.	8.875 in.	2.500 in.	10 blades	605 cfm	2,180 rpm	6.80 amps	Black
9.000 in.	9.750 in.			10.250 in.	2.500 in.	10 blades	790 cfm	2,180 rpm	6.80 amps	Black	PCE185.1002	
10.000 in.	11.000 in.			11.250 in.	2.500 in.	10 blades	850 cfm	2,180 rpm	6.80 amps	Black	PCE185.1001	
12.000 in.	12.500 in.			12.875 in.	3.375 in.	10 blades	1,107 cfm	2,250 rpm	6.80 amps	Black	PCE185.1005	
14.000 in.	14.500 in.			14.875 in.	3.500 in.	10 blades	1,585 cfm	1,945 rpm	7.90 amps	Black	PCE185.1007	
					3.500 in.			2,215 cfm	2,270 rpm	8.50 amps	Black	PCE185.1009
					(BM) 4.500 in.		10 blades	2,560 cfm	2,850 rpm	10.50 amps	Black	PCE185.1010
					3.500 in.			2,215 cfm	2,270 rpm	8.50 amps	Chrome	PCE185.1012
					(BM) 4.500 in.			2,560 cfm	2,850 rpm	10.50 amps	Chrome	PCE185.1011

(BM) = Big Motor

Electric Fan Mounting

Speedmaster™ electric fan nylon mounting kits offer Surloc technology that results in one of the strongest radiator cable ties on the market. The Surloc technology is an advanced interlocking design to guarantee a strong connection. The Speedmaster™ electric fan nylon mounting kits are made from a high temp nylon that can withstand the harshest engine bay environments.



Mounting Type	Quantity	SKU
Zip Ties	Set of 4	PCE182.1001
Zip Ties	Set of 100	PCE182.1002

Fan Shrouds

Speedmaster™ aluminum fan shrouds not only look great, but they're also the answer to affordable cooling for your vehicle. These low-profile shrouds are designed to easily mount an electric fan to our Speedmaster™ universal radiators, and they direct more air through the radiator for better cooling. This unit will mount by simply sliding it over the top rail and bolting it to the bottom rail with some self tapping screws or bolts.



Application	Fan Quantity	Fan Diameter (in)	Fan Shroud Height (in)	Fan Shroud Width (in)	SKU
31" Radiators	Dual	12.000 in.	19.000 in.	25.000 in.	PCE516.1001
28" Radiators	Dual	12.000 in.	19.000 in.	22.000 in.	PCE516.1002

Fan Switches, Thermal

Sending Unit

Speedmaster™ temperature sending units are designed to allow your electric fan to turn on and off at a desired temperature. These switches are recommended for all electric fan installations and are available in several different temperature ranges.



Adjustable fan control kit

Speedmaster™ adjustable fan wiring kits are designed to give you the adjustable temperature control you've been looking for. These wiring kits feature an adjustable thermal switch module, with a unique chip temperature sensor to ensure accurate temperature readings to within +/- 1 degree.



Non-adjustable fan control Relay

Speedmaster™ kits provide constant voltage, protect from voltage and amperage spikes, and keep fan(s) from feeding back through the system. These fan relay kits are a necessity if you're adding an on/off switch to your electric fan circuit.



Thermal Switch Style	Sending Unit Style	Sending Unit Included	Fan Quantity	Adjustment Range (F)	Fan On Temp. (F)	Fan Off Temp. (F)	Relay Included	Wiring Harness Included	SKU
Adjustable fan control kit	Radiator probe	Yes	Single/Dual	0-248 degrees F	-	-	No	No	PCE184.1005
Non-adjustable fan control kit	-	No	Single/Dual	-	-	-	Yes	Yes	PCE184.1007
Sending unit only	Thread-in (3/8-18 NPT)	Yes	-	-	200 degrees F	185 degrees F	No	No	PCE184.1003
					185 degrees F	175 degrees F			PCE184.1001

Cooling

Overflow Tanks

Speedmaster™ radiator overflow tanks are both functional and stunning to look at. They are quality-manufactured from stainless steel and are available in 18 to 80 oz. sizes. Their precision construction ensures a leak-proof seal and lasting durability. The tank comes with a removable cap so you can easily check the coolant level. They work under the same principals as OEM tanks.



Overflow Tank Material	Diameter (in)	Capacity	Length (in)	Vented	Inlet Quantity	Inlet Attachment	Inlet Size	Outlet Quantity	Outlet Attachment	Outlet Size	Mounting	SKU
Stainless steel		18 oz.	12.000 in.									PCE188.1001
		20 oz.	13.000 in.									PCE188.1002
		24 oz.	15.000 in.									PCE188.1003
	2.000 in.	28 oz.	17.000 in.	Yes	One	Slip-on	1/4 in.	One	Slip-on	1/4 in.	Bolt-in	PCE188.1004
		30 oz.	18.000 in.									PCE188.1005
		32 oz.	19.000 in.									PCE188.1006
		36 oz.	21.000 in.									PCE188.1007
		41 oz.	11.000 in.									PCE188.1008
		45 oz.	12.000 in.									PCE188.1009
		48 oz.	13.000 in.									PCE188.1010
3.000 in.	56 oz.	15.000 in.	Yes	One	Slip-on	1/4 in.	One	Slip-on	1/4 in.	Bolt-in	PCE188.1011	
	68 oz.	18.000 in.									PCE188.1012	
	76 oz.	20.000 in.									PCE188.1013	
	80 oz.	21.000 in.									PCE188.1014	

Catch Cans

Speedmaster™ catch cans are specially designed with a quenching plate to cool hot oil vapor and turn it into a liquid so it can be collected in the base. They are manufactured from durable aluminum and polished finish. They come with a washable stainless screw on filter/breather with o-ring to stop it coming loose with vibration. The high volume tap allows quick draining and is threaded for attaching a barbed adapter and hose for hard to get to installations.

- Female -10AN fittings/bungs
- Robotically TIG welded
- Stainless steel breather with o-ring to prevent loosening with vibration
- Cleanable & reusable stainless steel breather filter element
- High volume drain tap for fast & easy draining



Shape	Capacity	Length (in)	Size (in):	Vented	Drain Valve Included	Inlet Quantity	Inlet Attachment	Inlet Size	Overflow Tank Mounting	SKU
Rectangular	1.0 qt.	3.150 in.	3.150 in. W x 6.300 in. H	Yes	Yes	Two	Female threads	-10 AN	Bolt-in	PCE188.1022
Rectangular	2.0 qt.	4.330 in.	4.330 in. W x 6.300 in. H	Yes	Yes	Two	Female threads	-10 AN	Bolt-in	PCE188.1023
Rectangular	3.5 qt.	4.725 in.	4.725 in. W x 9.840 in. H	Yes	Yes	Two	Female threads	-10 AN	Bolt-in	PCE188.1024

Coolant Expansion Tank

Speedmaster™ Coolant Overflow Tank is a direct bolt-in and are designed to fit in the same location as your stock tank. Speedmaster™ expansion tanks provide increased strength and a more reliable performance than stock plastic to prevent fluids from leaking onto the ground and being lost out of your cooling system completely. They are built from strong .100 in. aluminum and 100 percent pressure- tested to eliminate leak.



Ref.	Application	SKU
a.	Ford Mustang 1996-04	PCE188.1016
b.	Ford Mustang 2005-10	PCE188.1017
c.	Dodge 2005-12 2.7L to 6.1L	PCE188.1018
d.	Universal	PCE188.1019

Water Necks

These chrome water necks from Speedmaster™ add a touch of class to your cooling system.



Application	Ref.	Water Neck Style	Swivel	Sealing Style	Water Neck Material	Water Neck Finish	SKU
Chevrolet SBC 350 1968-86	e.	45 degree	No	Gasket	Aluminum	Chrome	PCE191.1001
	f.	15 degree	No	O-ring	Steel	Chrome	PCE191.1011
Chevrolet SBC 350	g.	Straight up	No	O-ring	Aluminum	Polished	PCE191.1002
	h.	45 degree	Yes	O-ring	Aluminum	Chrome	PCE191.1004
	i.	90 degree	Yes	O-ring	Aluminum	Polished	PCE191.1005
	j.	15 degree	Yes	O-ring	Aluminum	Chrome	PCE191.1006
	k.	45 degree	No	Gasket	Aluminum	Polished	PCE191.1007
	l.	90 degree	Yes	O-ring	Aluminum	Chrome	PCE191.1008
Ford SB 289 302 351 Windsor 1965-75	k.	45 degree	No	Gasket	Aluminum	Chrome	PCE191.1003
Ford 302 351C Cleveland	l.	Straight up	No	Gasket	Steel	Chrome	PCE191.1015
Ford 429 460	m.	90 degree	No	O-ring	Steel	Chrome	PCE191.1013
							PCE191.1014

Water Pumps

More Coolant Flow

Electrical Water Pumps

Speedmaster™ electric water pumps eliminate unnecessary weight and impeller drag experienced at high RPM. These durable but light weight aluminum pumps push up to 35 gallons of water per minute of coolant circulation. Speedmaster™ electric water pumps give you the flow that you need, without costing you horsepower. CNC-machined from T-6 aluminum, these lightweight pumps have a direct-drive 12 V motor, spinning a redesigned impeller on a stainless steel shaft. Speedmaster™ pumps draw just 5.8 amps. Because they don't run off of your crank, they won't eat up race-winning horsepower. Other features include availability in several colors, superior RFI suppression, and a removable center section for cam adjustment or replacement.

Flow Rate @ 12 Volts (gpm)	35 GPM
Hose Adapter Thread Size	1 in. NPT
Inlet Hose Size	1 3/4 in.
Inlet Hose Attachment	Nipple
Overall Depth (in)	≈ 6.500 in.
Amp Draw	5.80 amps
Weight	≈ 5.500 lbs.

a STD



Finish:



b Slim



Ref.	Application	Pump Finish	SKU
a.	Chevrolet SBC 350	Chrome	PCE194.1001
		Red	PCE194.1002
		Black	PCE194.1003
	Chevrolet BBC 454	Chrome	PCE194.1004
		Red	PCE194.1005
		Black	PCE194.1006
	Ford SB 289 302 351 Windsor	Chrome	PCE194.1007
		Blue	PCE194.1008
		Black	PCE194.1009
	Ford 302 351C Cleveland	Chrome	PCE194.1010
Chrome		PCE194.1011	
Blue		PCE194.1012	
Ford 429 460	Black	PCE194.1013	
	Chrome	PCE194.1014	
b.	GM LS1	Polished	PCE194.1016
		Polished	PCE194.1017
	Chevrolet BBC 454	Polished	PCE194.1018

Water Pump Spacers

Get the additional clearance you need for your belt, aluminum timing covers or gear drive timing system with Speedmaster™ steel water pump spacers. These kits include the necessary gaskets for installation.



Speedmaster™ water pump pulley shim kits are designed to provide proper drive belt alignment with your water pump. They are installed between the water pump pulley and the drive flange. The Speedmaster™ water pump pulley shim kits contain one 1/16 in. spacer, one 1/8 in. spacer, and one 3/16 in. spacer. The Center Hole Inside Diameter is 0.750 in.



Electric Water Pump, Replacement Components

Motor

We have you covered with this high quality replacement. Speedmaster™ replacement electric water pump motors are manufactured to maintain high flow rates and the high quality you expect from Speedmaster™.



Legs

Speedmaster™ mounting kits allow you to mount your water pump to your vehicle. These computer-machined brackets are manufactured from high quality materials and come with a chrome finish.



Inlet fittings

Speedmaster™ water pump inlet fittings are made of computer-designed and machined billet aluminum. They have an NPT fitting on one end and a smooth hose nipple on the other.



- a. PCE192.1002 Chevy SBC Short Water Pump Leg 1/8" Spacer Kit w/ Gaskets
- b. PCE192.1001 Universal Chevy Ford Water Pump Pulley 3 Shim Kit Set (1/16" 1/8" 3/16")
- c. PCE193.1001 Electric Water Pump Motor Only Chrome
PCE193.1013 Red
PCE193.1014 Black
- d. PCE193.1004 Chevy SBC 350 Chrome Legs (2Pcs)
PCE193.1006 Chevy BBC 454
PCE193.1007 Ford SB 289 302 351 Windsor
PCE193.1008 Ford 302 351C Cleveland
PCE193.1009 Ford 429 460
PCE193.1012 Holden 253 304 308
- e. PCE193.1003 1 1/2" hose Connection Inlet Fitting
PCE193.1010 1 3/4"
- f. PCE193.1011 1 3/4" x 5" Long Hose Connection Inlet Fitting

Mechanical Water Pumps



Speedmaster™ high-volume water pumps have a ribbed aluminum housing and a heavy duty ball/roller bearing assembly. Most Speedmaster™ water pumps have a bigger impeller and larger cavity size to flow 35 percent more coolant than stock. Choose long or short styles in a natural or shiny polished finishes. Get high-flow for your car with Speedmaster™ water pumps.

How to determine if your water pump is short or long style?

It is important to use the correct style water pump or the pulleys in the engine may not line up correctly. For Chevy V8 the quick and dirty way to determine if you have a long or short water pump is to try and stick your fingers behind the timing cover, this is not possible with the short pump. A more accurate way is to measure the distance from the engine block to the mounting surface, a long water pump is $\approx 7"$ and a short is $\approx 5\ 5/8"$.

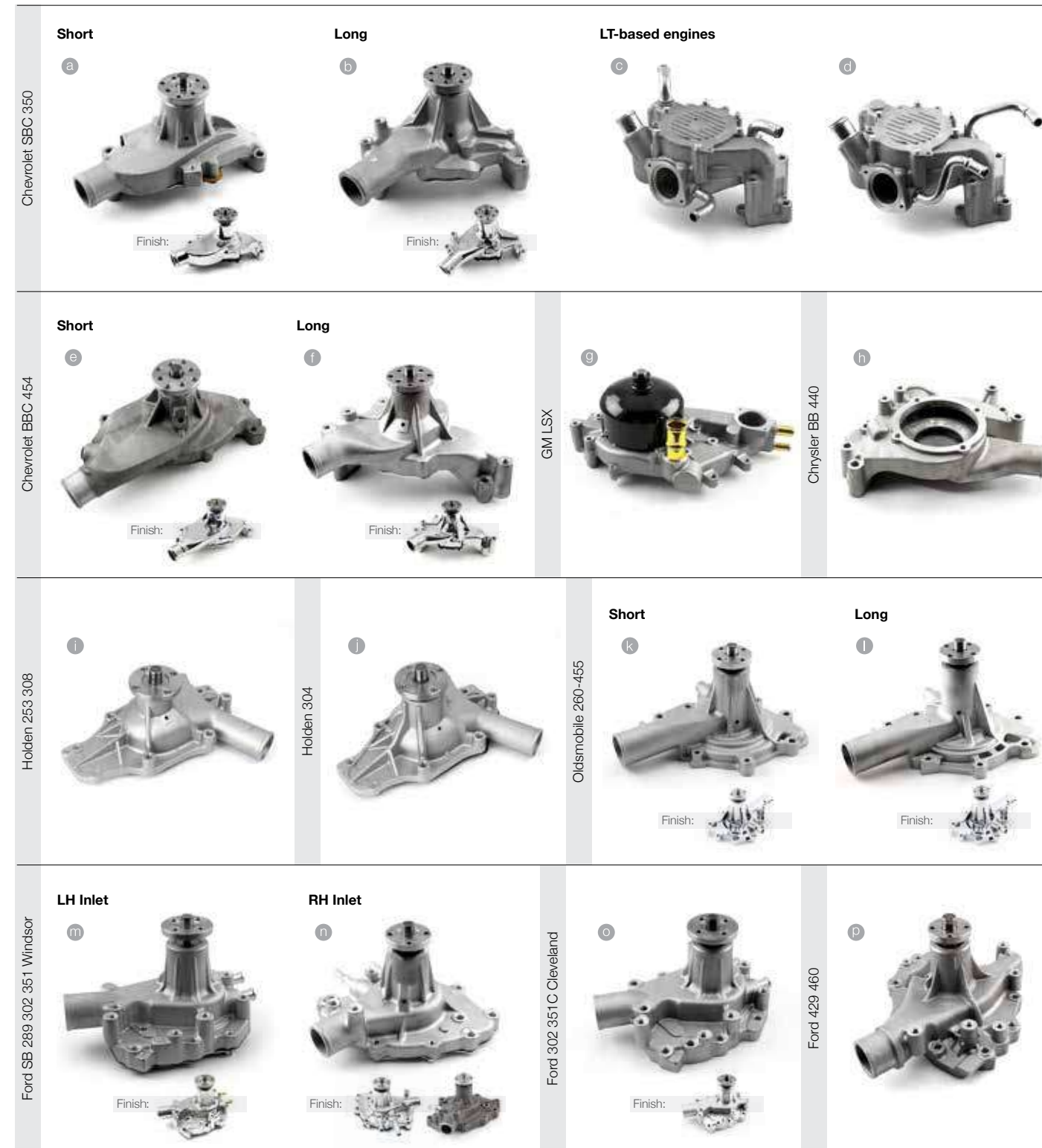
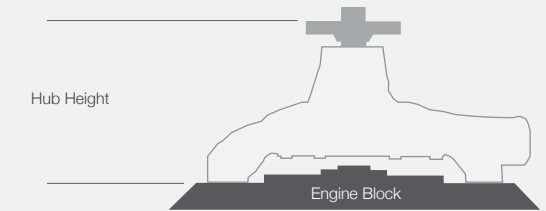
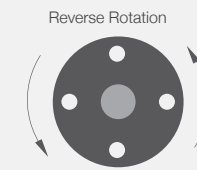
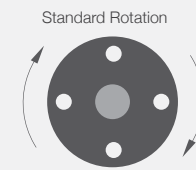

Ref.	Application	Pump Style	Pump Material	Rotation	Pump Finish	SKU
a.	Chevrolet SBC 350	Short	Aluminum	STD	Chrome	PCE195.1002
					Polished	PCE195.1004
					Natural	PCE195.1001
b.	Chevrolet SBC 350	Long	Aluminum	STD	Chrome	PCE195.1006
					Polished	PCE195.1008
					Natural	PCE195.1005
c.	Chevy SB 350 LT1 1993-94	-	Aluminum	STD	Natural	PCE195.1022
					Reverse	PCE195.1009
d.	Chevy SB 350 LT1 1995-96	-	Aluminum	STD	Natural	PCE195.1023
					Reverse	PCE195.1034
e.	Chevrolet BBC 454	Short	Aluminum	STD	Chrome	PCE195.1011
					Polished	PCE195.1012
					Natural	PCE195.1010
f.	Chevrolet BBC 454	Long	Aluminum	STD	Chrome	PCE195.1014
					Polished	PCE195.1015
					Natural	PCE195.1013
g.	GM LSX	-	Aluminum	STD	Natural	PCE195.1032
h.	Chrysler BB 440	Housing Only	Aluminum	-	Natural	PCE509.1001
i.	Holden 253 308	-	Aluminum	STD	Natural	PCE195.1020
j.	Holden 304	-	Aluminum	STD	Natural	PCE195.1021
k.	Oldsmobile	Short	Aluminum	STD	Chrome	PCE195.1027
					Natural	PCE195.1030
l.	Oldsmobile	Long	Aluminum	STD	Chrome	PCE195.1028
					Natural	PCE195.1031
m.	Ford SB 289 302 351 Windsor	LH inlet	Aluminum	STD	Chrome	PCE195.1025
					Polished	PCE195.1035
					Natural	PCE195.1016
n.	Ford SB 289 302 351 Windsor	RH inlet	Aluminum	STD	Chrome	PCE195.1026
					Polished	PCE195.1036
					Natural	PCE195.1017
o.	Ford 302 351C Cleveland	-	Aluminum	STD	Cast Iron	PCE195.1024
					Natural	PCE195.1024
p.	Ford 429 460	-	Aluminum	STD	Chrome	PCE195.1037
					Polished	PCE195.1038
					Natural	PCE195.1018
o.	Ford 302 351C Cleveland	-	Aluminum	STD	Reverse	PCE195.1033
					Natural	PCE195.1033
p.	Ford 429 460	-	Aluminum	STD	Natural	PCE195.1019



IS VEGAS MOTOR



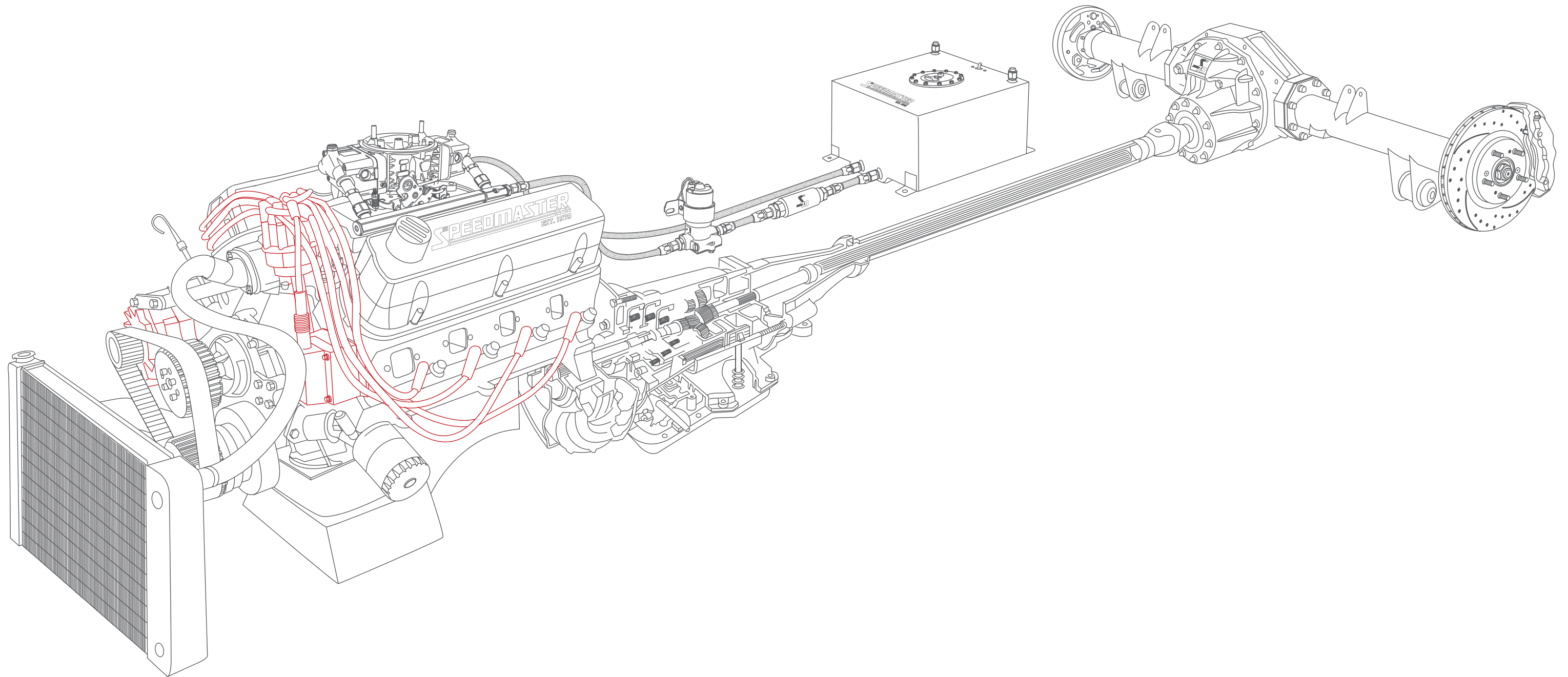

Procomp Electronics (PCE) "Engine Related Electronic Parts Department", our electronics range of products are the finest components you can install on your car whether it's a daily driver, dirt tracker, 4-wheel drive or Big Foot. The PCE team at Speedmaster™ designs, develops, tests and manufactures the entire line of Speedmaster™ Electronic products including Ignition Controls, Coils, Timing Accessories and Spark Plug Wires and Accessories.

Distributors

Fire it Up!



The distributor handles several jobs. Its first job is to distribute the high voltage from the coil to the correct cylinder. This is done by the cap and rotor. The coil is connected to the rotor, which spins inside the cap. The rotor spins past a series of contacts, one contact per cylinder. As the tip of the rotor passes each contact, a high-voltage pulse comes from the coil. The pulse arcs across the small gap between the rotor and the contact (they don't actually touch) and then continues down the spark-plug wire to the spark plug on the appropriate cylinder.



Ready-to-Run & Professional Series are available with Male & Female Caps



Caps are also available in Blue and Red



All-in-One

- Trigger
- Module
- Coil

Speedmaster™ All-in-One HEI Distributors line is the favorite for muscle cars, street rods and even circle track racers. The integrated coil keeps underhood wiring clean, and for race cars, the idea of running one wire to the distributor keeps things simple. When it comes to performance, the Speedmaster™ All-in-One series answers the need for a strong, accurate and high performance HEI where the stock HEI falls short.



Ready-to-Run

- Trigger
- Module
- Coil

Speedmaster™ Ready-to-Run distributors are a completely self contained high performance, high output ignition ideal for your hot rod! The "spark plug" type terminals offer secure wire attachment. Under the brass terminals of the cap and rotor is an extremely accurate magnetic pickup that never requires adjustment along with an easy to adjust mechanical advance mechanism.



Professional

- Trigger
- Box
- Coil

Speedmaster™ Professional Distributors are designed for those who are serious about performance. Extremely accurate magnetic pickup which never requires adjustment followed by an easy-to-adjust mechanical advance assembly. The 0.5" steel shaft that spins the advance and reluctor is guided by a sealed ball bearing and long sintered bushing. This combination provides stable timing signals and spark delivery at any RPM.



Pro OEM Replacement

- Trigger
- Box
- Coil

Speedmaster™ Pro OEM Series Distributors are designed for enthusiasts that are serious about OEM performance. They are a high quality direct OEM replacement part and is ready for installation straight out of the box.



Legend

- Included
- Needed

Legend

- Included
- Needed



Aluminum body



Trigger style



Advance springs

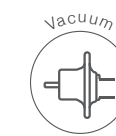

Advance canister

These Speedmaster™ HEI (High Energy Ignition) Distributors are a perfect upgrade for the enthusiast looking for an easy to install performance distributor, to put on your daily driver or weekend warrior. Speedmaster™ 6000 series HEI distributors are packed with high-quality features and components. They feature a 65,000 V coil, medium weight advance springs, and an aluminum housing. These distributors use a centrifugal advance assembly with coated weights and welded weight pins. Inside the distributors, the ignition module and coil work together to produce a stout spark to light the fuel mixture for great performance. The high voltage is transferred through a specially designed rotor to the brass terminals of the distributor cap and out to the plugs. The Speedmaster™ 6000 series distributors prove that quality does not have to be expensive!

6000 distributors feature the following:

- Assembled entirely from 100% NEW components (unlike some of our competitors!)
- CNC machined aluminum body
- Adjustable vacuum advance
- Premium cap with brass terminals
- Low saturation ignition module
- High output coil
- Reliable operation through 7000 RPM
- Billet 4340 steel gear for use on cast cams*
- Large diameter cap (for better spark alignment)

More 6000 Versions:



6000 6000 RPM 6000 Plus



6000

Application	Cap Style	Notes	SKU
Amc Dr1618X 6 Cylinder	Male/HEI	-	PCE376.1068
Amc Jeep 290 304 360 401	Male/HEI	-	PCE376.1065
Amc Jeep Amc 6 Cyl 232 258 4.0 4.2	Male/HEI	-	PCE376.1067
Chevrolet Inline 6 194 230 250 292	Male/HEI	-	PCE376.1066
		-	PCE376.1032
Chevrolet SBC 350 BBC 454	Male/HEI	Solid Cap w/ Tach Drive	PCE376.1030 PCE376.1036
Chevrolet V6 3.8L 4.3L	Male/HEI	-	PCE376.1027
Ford SB 289 302 Windsor	Male/HEI	-	PCE376.1038
Ford 351W Windsor	Male/HEI	-	PCE376.1042
		-	PCE376.1046
Ford 302 351C Cleveland 460	Male/HEI	Late Model	PCE376.1182
Ford Fe 390 427 428	Male/HEI	-	PCE376.1078
Holden 253 304 308	Male/HEI	-	PCE376.1049
Holden 6 Cyl	Male/HEI	-	PCE376.1050
Mopar Chrysler SB 318 340 360	Male/HEI	-	PCE376.1051
Mopar Chrysler BB 440	Male/HEI	-	PCE376.1052
Pontiac 326 400 455	Male/HEI	-	PCE376.1053
Oldsmobile 400 425 455	Male/HEI	-	PCE376.1054

6000 RPM

Application	Cap Style	SKU
Chevrolet SBC 350 BBC 454	Male/HEI	PCE376.1188
Holden 253 304 308	Male/HEI	PCE376.1189

6000 Plus

Application	Cap Style	SKU
Chevrolet SBC 350 BBC 454	Male/HEI	PCE376.1055
Ford 302 351C Cleveland 460	Male/HEI	PCE376.1061
Ford 351W Windsor	Male/HEI	PCE376.1060
Ford SB 289 302 Windsor	Male/HEI	PCE376.1059
Holden 253 304 308	Male/HEI	PCE376.1062
Oldsmobile 400 425 455	Male/HEI	PCE376.1064
Pontiac 326 400 455	Male/HEI	PCE376.1063



Thunder



Aluminum body



Trigger style



Advance springs

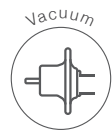

Advance canister



Module & Coil

Speedmaster™ Thunder Series HEI Distributors are a favorite for muscle cars, street rods and even circle track racers. The integrated coil keeps underhood wiring clean, and for race cars, the idea of running one wire to the distributor keeps things simple. When it comes to performance, the Thunder series answers the need for a strong, accurate and high performance HEI where the stock HEI falls short. Tig welded on top of the distributor shaft is an adjustable centrifugal advance assembly. The Vacuum advance canister, improves economy while cruising, for those concerned. All of this is assembled around a precision and great looking CNC-machined housing. The distributor features a 65,000 V coil and is supplied with thunder cap, rotor, coil cover and heavy duty gear so it is ready to install in your engine! Inside the distributors, the ignition module and coil work together to produce a stout spark to light the fuel mixture for great performance. The high voltage is transferred through a specially designed rotor to the brass terminals of the distributor cap and out to the plugs.

The Speedmaster™ Thunder series distributors prove that quality does not have to be expensive! Thunder module and coil is designed to produce increased energy through to 9,000 rpm!

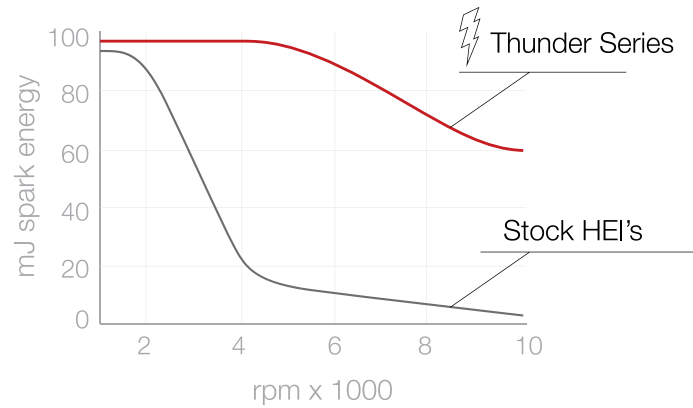

Thunder module and coil are designed to produce increased energy through to **9,000 rpm!**



Thunder

Thunder Plus



Application	Cap Style	SKU
Chevrolet SBC 350 BBC 454	Male/HEI	PCE376.1069
Ford 289 302 Windsor	Male/HEI	PCE376.1070
Ford 302 351C 460 Cleveland	Male/HEI	PCE376.1077
Ford 302 351C Cleveland 460	Male/HEI	PCE376.1072
Ford 351W Windsor	Male/HEI	PCE376.1071
Holden 253 304 308	Male/HEI	PCE376.1073

Application	Cap Style	SKU
Chevrolet SBC 350 BBC 454	Male/HEI	PCE376.1074
Ford 289 302 Windsor	Male/HEI	PCE376.1075
Ford 351W Windsor	Male/HEI	PCE376.1076



Magneto



Aluminum body



Trigger style



Advance springs

Speedmaster™ Magneto Style Series HEI Distributors are a favorite for muscle cars, street rods and even circle track racers. The integrated coil keeps underhood wiring clean, and for race cars, the idea of running one wire to the distributor keeps things simple. When it comes to performance, the Magneto series answers the need for a strong, accurate and high performance HEI where the stock HEI falls short. Tig welded in the heart of the distributor shaft is an adjustable centrifugal advance assembly. Which improves economy while cruising. All of this is assembled around a precision and great looking CNC-machined housing.

The distributor is supplied with Magneto a male styled cap, rotor, coil cover and heavy duty gear so it is ready to install in your engine! Magneto module and coil is designed to produce increased energy through to 9,000 rpm!



Magneto



Magneto RPM

Magneto module and coil are designed to produce increased energy through to **9,000 rpm!**



Application	Cap Style	SKU
Chevrolet SBC 350 BBC 454	Male/HEI	PCE376.1193
Ford SB 289 302 Windsor	Male/HEI	PCE376.1194
Ford 351W Windsor	Male/HEI	PCE376.1195
Ford 302 351C Cleveland	Male/HEI	PCE376.1209
Ford 302 351C Cleveland	Male/HEI	PCE376.1210
Holden 253 304 308	Male/HEI	PCE376.1021
Mopar Chrysler SB 318 340 360	Male/HEI	PCE376.1196
Mopar Chrysler BB 383 440	Male/HEI	PCE376.1197
Pontiac 326 400 455	Male/HEI	PCE376.1198
Oldsmobile 400 425 455	Male/HEI	PCE376.1199

Application	Cap Style	SKU
Chevrolet SBC 350 BBC 454	Male/HEI	PCE376.1016
Ford SB 289 302 Windsor	Male/HEI	PCE376.1017
Ford 351W Windsor	Male/HEI	PCE376.1018
Ford 302 351C Cleveland	Male/HEI	PCE376.1019
Ford 302 351C Cleveland	Male/HEI	PCE376.1020
Mopar Chrysler SB 318 340 360	Male/HEI	PCE376.1022
Mopar Chrysler BB 383 440	Male/HEI	PCE376.1023
Pontiac 326 400 455	Male/HEI	PCE376.1024
Oldsmobile 400 425 455	Male/HEI	PCE376.1025



7000



Cast
Aluminum body



Magnetic
Trigger style



Mechanical
Advance springs



Vacuum
Advance canister



8020



CNC
Machined aluminum body



Magnetic
Trigger style



Mechanical
Advance springs

Speedmaster™ 7000 Series Cast Body Ready-to-Run distributors are the perfect upgrade for your outdated and worn out stock distributor. All that is required to install one of these distributors is to hook up two wires and you are Ready-to-Run!

A maintenance free magnetic pick up inside the distributor is used to trigger a state of the art ignition module under the chrome cover. The increased output of this self contained ignition easily outperforms stock ignitions and helps to smooth out the power-band from idle to high RPM. For stability and endurance, an oversize steel shaft spins in a top mounted sealed bearing while an extra-long sentried bushing guides the shaft at the bottom of the housing. To increase gas mileage, we included a vacuum advance assembly, and you can tailor the mechanical advance curve to suit your engine. For excellent street performance, the 7000 Series Cast Ready-to-Run distributor is the best choice!



7000



7000 RPM



Application	Cap Style	Notes	SKU
Chevrolet 348 409	Male/HEI	-	PCE376.1095
Chevrolet V6 3.8L 4.3L	Male/HEI	-	PCE376.1080
Chevrolet SBC 350 BBC 454	Male/HEI	-	PCE376.1079
Ford SB 289 302 Windsor	Male/HEI	-	PCE376.1081
Ford 302 Windsor 5.0L EFI	Male/HEI	-	PCE376.1082
Ford 351W Windsor	Male/HEI	-	PCE376.1083
Ford 351W Windsor 5.7L EFI	Male/HEI	-	PCE376.1084
Ford 302 351C Cleveland Early 460	Male/HEI	-	PCE376.1085
Ford 302 351C Cleveland Late	Male/HEI	-	PCE376.1086
Holden Inline 6 186 202	Female/HEI	-	PCE376.1088
Holden 253 304 308	Male/HEI	-	PCE376.1087
Mopar Chrysler 6 Cyl	Female/HEI	Bronze Gear	PCE376.1006
Mopar Chrysler 6 Cyl	Female/HEI	-	PCE376.1090
Mopar Chrysler SB 318 340 360	Male/HEI	-	PCE376.1089
Mopar Chrysler BB 383	Male/HEI	-	PCE376.1092
Mopar Chrysler BB 440	Male/HEI	-	PCE376.1091
Pontiac 326 400 455	Male/HEI	-	PCE376.1093
Oldsmobile 400 425 455	Male/HEI	-	PCE376.1094

Application	Cap Style	SKU
Chevrolet 348 409	Male/HEI	PCE376.1208
Chevrolet SBC 350 BBC 454	Male/HEI	PCE376.1183
Ford SB 289 302 Windsor	Male/HEI	PCE376.1200
Ford 351W Windsor	Male/HEI	PCE376.1201
Ford 302 351C Cleveland Early 460	Male/HEI	PCE376.1202
Ford 302 351C Cleveland Late	Male/HEI	PCE376.1211
Holden Inline 6 186 202	Female/HEI	PCE376.1212
Holden 253 304 308	Male/HEI	PCE376.1203
Mopar Chrysler SB 318 340 360	Male/HEI	PCE376.1204
Mopar Chrysler BB 440	Male/HEI	PCE376.1205
Pontiac 326 400 455	Male/HEI	PCE376.1206
Oldsmobile 400 425 455	Male/HEI	PCE376.1207



8020

8020 RPM



8020 M-Style

8020 M-Style RPM



8020

Application	Cap Style	Notes	SKU
Chevrolet SBC 350 BBC 454	Male/HEI	No Plug	PCE376.1218
Chevrolet V6 3.8L 4.3L	Female/HEI	Plug	PCE376.1121
		No Plug	PCE376.1226
Ford 289 302 Windsor	Male/HEI	Plug	PCE376.1123
		Angle Drive	PCE376.1139
Ford 302 Windsor 5.0L EFI	Male/HEI	-	PCE376.1124
		No Plug	PCE376.1225
Ford 351W Windsor	Male/HEI	Plug	PCE376.1125
		Angle Drive	PCE376.1140
Ford 351C Cleveland 460	Male/HEI	Plug	PCE376.1126
		Angle Drive	PCE376.1141
Ford FE 390-428	Male/HEI	Plug	PCE376.1134
		No Plug	PCE376.1229
Holden 253 304 308	Male/HEI	Plug	PCE376.1128
Holden Inline 6 186 202	Male/HEI	Plug	PCE376.1129
Mopar Chrysler SB 318 340 360	Male/HEI	Plug	PCE376.1130
Mopar Chrysler BB 383	Male/HEI	Plug	PCE376.1132
Mopar Chrysler BB 440	Male/HEI	Plug	PCE376.1131
Pontiac 350-455	Male/HEI	Plug	PCE376.1186
Oldsmobile 260-455	Male/HEI	Plug	PCE376.1187
Oldsmobile 400 425 455	Male/HEI	Plug	PCE376.1213

8020 RPM

Application	Cap Style	SKU
Ford 289 302 Windsor	Male/HEI	PCE376.1227
Ford 351c Cleveland 460	Male/HEI	PCE376.1222
Ford 351W Windsor	Male/HEI	PCE376.1223
Ford Flat Head 239 1939-48	No Cap	PCE376.1244
Mopar Chrysler 318 340 360	Male/HEI	PCE376.1220

8020 M-Style

Application	Cap Style	Notes	SKU
		No Vacuum	PCE376.1120
Chevrolet SBC 350 BBC 454	Male/HEI	w/ Tach Drive	PCE376.1184
		Angle Drive	PCE376.1138
Ford 289 302 Windsor	Male/HEI	w/ Vacuum	PCE376.1228
Ford 351W Windsor	Male/HEI	w/ Vacuum	PCE376.1224
Ford 351C Cleveland 460	Male/HEI	w/ Vacuum	PCE376.1221

8020 M-Style RPM

Application	Cap Style	SKU
Chevrolet SBC 350 BBC 454	Male/HEI	PCE376.1219
Ford 351c Cleveland 460	Male/HEI	PCE376.1215



All-Electronic



8000

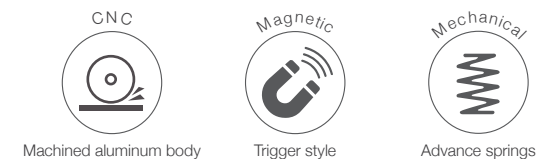

This is the latest range of Speedmaster™, Smart series all electronic advance distributors. This range of distributors are self-contained; in which they don't require ignition boxes to operate. They run state-of-the-art micro-processors and surface mount technology components. This setup allows users to adjust the curve themselves by simply moving the switched from the on and off positions.

The electronic distributors themselves do not use bob weights themselves to advance the distributor; all the advances are provided by the micro processor inside the distributor. In doing so you can choose your own setup from the 8 curves by simply playing with the switches.

Speedmaster™ 8000 Series Pro Billet distributors are designed for the enthusiast that is serious about performance but needs the small cap size due to space considerations when installed. They are precision CNC machined from billet 6061-T6 aluminum to exacting tolerances. The "spark plug" type terminals offer secure wire attachment. Under the brass terminals of the cap and rotor is an extremely accurate magnetic pickup that never requires adjustment along with an easy to adjust mechanical advance mechanism. The heavy duty 1/2" steel shaft is guided in a long sintered bushing as well as a sealed ball bearing at the top to precisely locate the reluctor. This combination yields stable timing and spark delivery at any RPM.

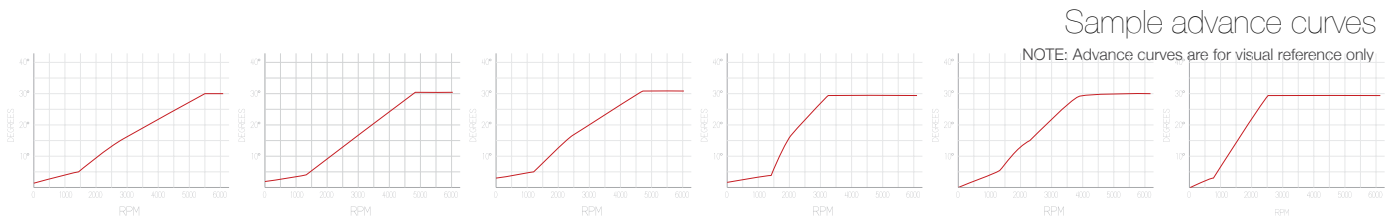
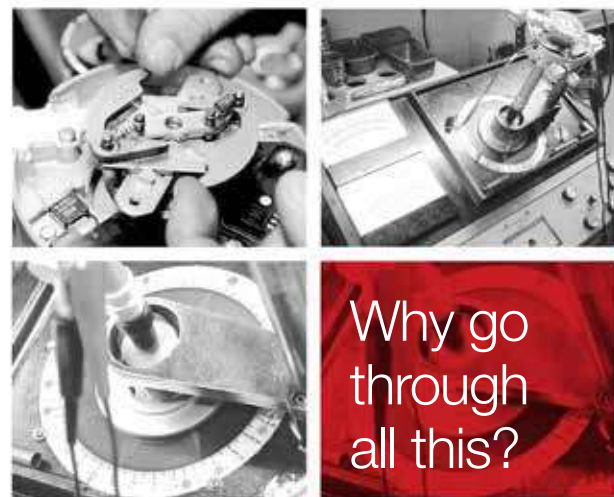

Application	Cap Style	SKU
Chevrolet SBC 350 BBC 454	Male/HEI	PCE376.1150
Ford 289 302 Windsor	Male/HEI	PCE376.1151
Ford 351W Windsor	Male/HEI	PCE376.1152
Ford 351C Cleveland Early 460	Male/HEI	PCE376.1153
Holden 253 304 308	Male/HEI	PCE376.1154



8000

Application	Cap Style	Notes	SKU
Chevrolet 348 409	Male/HEI	-	PCE376.1118
Chevrolet SBC 350 BBC 454	Male/HEI	Programmable Advance	PCE376.1119
		-	PCE376.1096
Chevrolet V6 3.8L 4.3L	Female/HEI	-	PCE376.1097
Ford 2.3L L4 1974-84	Male/HEI	-	PCE376.1148
Ford 289 302 Windsor	Male/HEI	-	PCE376.1100
Ford 302 351C Cleveland Early 460	Male/HEI	-	PCE376.1107
Ford 302 351C Cleveland Late 460	Male/HEI	-	PCE376.1109
Ford 302 Windsor 5.0L EFI Windsor	Male/HEI	-	PCE376.1102
Ford 351W Windsor	Male/HEI	-	PCE376.1104
Ford Fe 390 427 428	Male/HEI	-	PCE376.1157
Ford Flat Head 225 239 1949-53	Male/HEI	-	PCE376.1156
Ford Flat Head 239 1939-48	No Cap	-	PCE376.1142
Holden 253 304 308	Male/HEI	-	PCE376.1111
Holden 304 EFI 5.0L Vn Vg Vp Series 1	Male/HEI	-	PCE376.1014
Holden 304 EFI 5.0L Vp Series 2 Vr Vs	Male/HEI	-	PCE376.1015
Holden Inline 6 186 202	Female/HEI	-	PCE376.1112
Mopar Chrysler BB 440	Male/HEI	-	PCE376.1115
Mopar Chrysler SB 318 340 360	Male/HEI	-	PCE376.1114
Pontiac 326 400 455	Male/HEI	-	PCE376.1116
Oldsmobile 400 425 455	Male/HEI	-	PCE376.1117
Amc Jeep 290 304 360 401	Male/HEI	-	PCE376.1155
Volkswagen H4 1954-79	Male/HEI	-	PCE376.1149

8000 M-Style

Application	Cap Style	Notes	SKU
Chevrolet 348 409	Male/HEI	-	PCE376.1230
Chevrolet SBC 350 BBC 454	Male/HEI	No Vacuum w/ Vacuum	PCE376.1135 PCE376.1136
Ford 289 302 Windsor	Male/HEI	w/ Vacuum	PCE376.1231
Ford 351W Windsor	Male/HEI	-	PCE376.1233
		w/ Vacuum	PCE376.1232
Ford 302C 351C Cleveland Early 460	Male/HEI	-	PCE376.1234
		w/ Vacuum	PCE376.1235
Mopar Chrysler SB 318 340 360	Male/HEI	-	PCE376.1236
Mopar Chrysler BB 440	Male/HEI	-	PCE376.1237
Pontiac 326 400 455	Male/HEI	-	PCE376.1238
Oldsmobile 400 425 455	Male/HEI	-	PCE376.1239

8000 TKE

Specially Designed for our Turckey EFI Systems



Application	Cap Style	SKU
Chevrolet SBC 350 BBC 454	Male/HEI	PCE376.1098
Ford 289 302 Windsor	Male/HEI	PCE376.1101
Ford 302 Windsor 5.0L EFI Windsor	Male/HEI	PCE376.1103
Ford 351W Windsor	Male/HEI	PCE376.1105
Ford 351W Windsor 5.7L EFI Windsor	Male/HEI	PCE376.1106
Ford 302 351C Cleveland Early 460	Male/HEI	PCE376.1108
Ford 302 351C Cleveland Late 460	Male/HEI	PCE376.1110
Holden 253 304 308	Male/HEI	PCE376.1113



8400



Machined aluminum body



Trigger style



Advance springs



9000



Machined aluminum body



Trigger style



Advance springs

Speedmaster™ 8400 Series Pro Billet Distributors are designed for enthusiasts that are serious about performance with space restrictions.

The 8400 Series features the following:

CNC machined from Billet 6061-T6 Aluminum to give them precision tolerances, high strength and incredible endurance. The Billet Distributors are equipped with a cap that has "spark plug" style terminals for secure wire attachment and maximum protection against crossfire.

Extremely accurate magnetic pickup which never requires adjustment followed by an easy-to-adjust mechanical advance assembly. Precision weights glide on nylon bushings for smooth advancement and different springs are available so a variety of advance curves can be tuned. The 1/2" steel shaft that spins the advance and reluctor is guided by a sealed ball bearing and long sintered bushing.



Speedmaster™ 9000 Series distributors feature CNC machined from Billet 6061-T6 Aluminum to give them precision tolerances, high strength and incredible endurance. The Billet Distributors are equipped with a large cap that has "spark plug" style terminals for secure wire attachment and maximum protection against crossfire. Extremely accurate magnetic pickup which never requires adjustment followed by an easy-to-adjust mechanical advance assembly.

Precision weights glide on nylon bushings for smooth advancement and different springs are available so a variety of advance curves can be tuned. The 0.500 in. steel shaft that spins the advance and reluctor is guided by a sealed ball bearing and long sintered bushing. This combination provides stable timing signals and spark delivery at any RPM. These are mainly used in high performance and racing vehicles.

This combination provides stable timing signals and spark delivery at any RPM.

8400 vs 8000: The major difference between the 8400 and 9000/8000 Series distributors is the mechanical advance system. The 8400 has the traditional advance adjustment in the top of the distributor under a round rotor button. This is help for customers who need to make changes to mechanical advance without pulling the distributor apart.



Application	Cap Style	SKU
Chevrolet SBC 350 BBC 454	Male/HEI	PCE376.1143
Ford 289 302 Windsor	Male/HEI	PCE376.1144
Ford 351W Windsor	Male/HEI	PCE376.1145
Ford 302 351C Cleveland Early 460	Male/HEI	PCE376.1146
Ford Fe 390 427 428	Male/HEI	PCE376.1245
Holden 253 304 308	Male/HEI	PCE376.1147

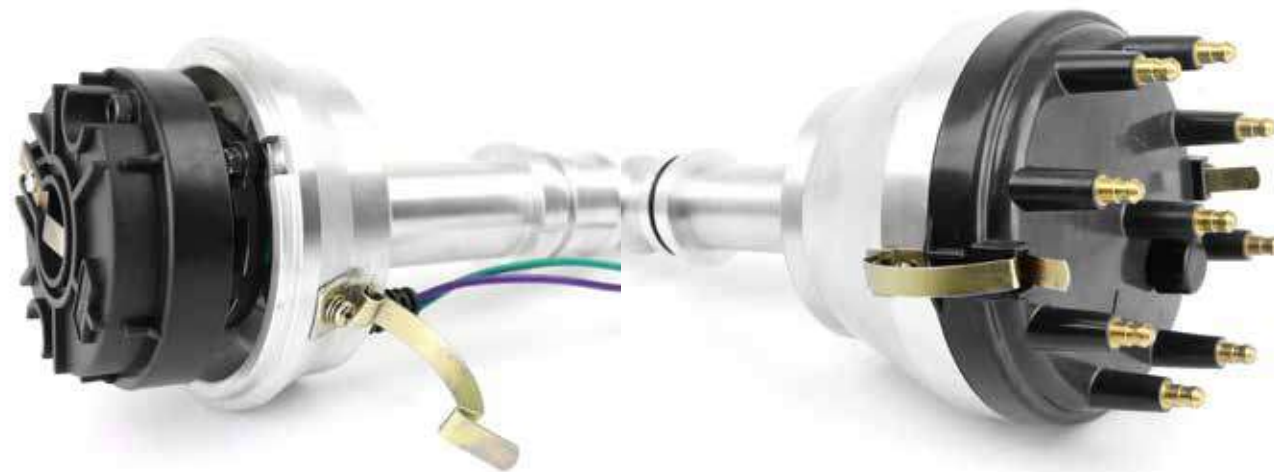

Application	Cap Style	SKU
Chevrolet SBC 350 BBC 454	Male/HEI	PCE376.1171
Ford 289 302 Windsor	Male/HEI	PCE376.1172
Ford 302 Windsor 5.0L EFI	Male/HEI	PCE376.1173
Ford 351W Windsor	Male/HEI	PCE376.1174
Ford 302 351C Cleveland Late 460	Male/HEI	PCE376.1176
Ford 351C Cleveland Early 460	Male/HEI	PCE376.1175
Holden 253 304 308	Male/HEI	PCE376.1177
Mopar Chrysler SB 318 340 360	Male/HEI	PCE376.1178
Mopar Chrysler BB 440	Male/HEI	PCE376.1179



Pro OEM

OEM Replacement Pro OEM Distributors are designed for enthusiasts that are serious about OEM performance. Restore proper spark in your machine with a brand new Pro OEM distributor from Speedmaster™. Comes complete with all new parts, they are a high quality direct OEM replacement part and is ready for installation straight out of the box. Perfect for replacing your old worn out distributor or for anyone needing a new distributor to complete a new engine swap.



Application	Ref.	Trigger Style	Advance Type	Cap Style	Housing Material	Housing Finish	SKU
Chevrolet 350 5.7L 1987-95 TBI TPI EFI Vortec	a.	Magnetic	Locked	Male/HEI	Billet aluminum	CNC Machined	PCE376.1001
Chevrolet V6 4.3L 1985-95 TBI TPI EFI Vortec	b.	Magnetic	Locked	Male/HEI	Billet aluminum	CNC Machined	PCE376.1002
Chevrolet 350 454 5.0L 5.7L 7.4L 1996-03 Vortec	c.	Magnetic	Computer-controlled	Crab style	Plastic	Black	PCE376.1013
Chevrolet V6 4.3L 1996-07 Vortec	d.	Magnetic	Computer-controlled	Crab style	Plastic	Black	PCE376.1012
	e.	Magnetic	Computer-controlled	Crab style	Aluminum	Natural	PCE376.1217
Chevrolet 350 LT1 LT4 5.7L 1992-94 Optispark I	f.	Optical	Computer-controlled	Crab style	Billet aluminum	CNC Machined	PCE376.1191
				Crab style			PCE376.1192
Chevrolet 350 LT1 LT4 5.7L 1994-97 Optispark II	g.	Optical	Computer-controlled	Crab style	Aluminum	Natural	PCE376.1007
				Crab style			PCE376.1008
Ford 302 Windsor 5.0L 1986-93 EFI	h.	Hall effect	Locked	Male/HEI	Billet aluminum	CNC Machined	PCE376.1004
Ford 302 Windsor 5.0L 1994-95 EFI	i.	Hall effect	Locked	Male/HEI	Billet aluminum	CNC Machined	PCE376.1003
Ford 351W Windsor 5.7L 1986-95 EFI	j.	Hall effect	Locked	Male/HEI	Billet aluminum	CNC Machined	PCE376.1005
Holden 304 EFI 5.0L VN VG VP Series 2 VR VS	k.	Magnetic	Locked	Male/HEI	Aluminum	Natural	PCE376.1009
Holden 304 EFI 5.0L Vp Series 2 Vr Vs	l.	Magnetic	Locked	Male/HEI	Aluminum	Natural	PCE376.1010
Holden 304 EFI 5.0L VT Series 1	m.	Magnetic	Locked	Male/HEI	Aluminum	Natural	PCE376.1011

Crank Trigger Kits

Stable Ignition Timing

Stable ignition timing is a necessity in performance engines. The ignition must be triggered at a precise time in relation to the position of the piston in the compression stroke. However, think of all the mechanical stretching and flexing that takes place through the timing chain, gears and cam before the distributor pickup triggers the ignition. The crankshaft on the other hand, knows exactly where each piston is, plus it is the most stable component of the engine in relation to piston position. That's why a Crank Trigger Wheel & Sensor Kit is needed.

Procomp Electronics uses a non-magnetic pickup which gets triggered by powerful magnets that are embedded in the trigger wheel. The only way to trigger the ignition is when a magnet passes the pickup. This non-magnet pickup is securely held in position by CNC machined aluminum brackets. These brackets feature a long adjustment slot providing a large range of accurate timing adjustments. Plus, many of the brackets can be used on either side of the balancer for easy installation. Most kits are supplied with several spacers for different accessories and pulley systems.

Each magnet is pressed and then riveted into the wheel to handle the fierce rpm and vibration that high horsepower engines put out. By installing the magnets in the trigger wheel, Procomp Electronics has done away with the chance of false triggering. As the engine is rotating, the magnets pass the Non-Magnetic Pickup and create a signal that triggers the Ignition. The magnets are the only thing that can trigger the ignition making it the most reliable and accurate way to trigger your ignition. Magnet Crank Trigger Kits must be used with an Ignition Control Box.



Ref.	Application	Pickup Included	Adjustable Mounting Bracket Included	Bracket Material	Bracket Finish	Crank Trigger Wheel Included	Crankshaft Wheel Material	Crankshaft Wheel Finish	SKU
a.	Chevrolet SBC 350	Yes	Yes	Billet aluminum	Red anodized	Yes	Aluminum	Red anodized	PCE376.1167
b.	Chevrolet BBC 454	Yes	Yes	Billet aluminum	Red anodized	Yes	Aluminum	Red anodized	PCE376.1168
c.	Ford SB 289 302 351 Windsor	Yes	Yes	Billet aluminum	Red anodized	Yes	Aluminum	Red anodized	PCE376.1166

Quick Tip



Setting the Air-Gap

The air-gap between the trigger wheel and the non-magnetic pickup is important to the operation of the crank trigger system, however its adjustment does not affect engine power or performance. The proper air-gap will result in a good trigger signal at cranking rpm through high rpm with no interference to the wheel. The optimum setting is generally between 0.050" – 0.080".

With the brackets and trigger wheel mounted (with the arrow on the wheel facing out) position the pickup within 0.050" – 0.080" from the wheel then tighten the locknut (Do not over tighten).

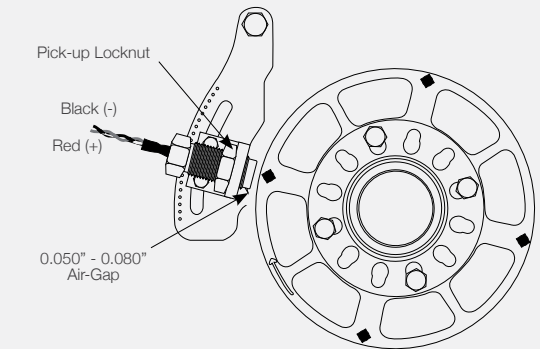

Timing the Ignition System

The timing can be adjusted by sliding the pickup holder assembly up or down in the bracket slot. To retard the timing, move the pickup holder assembly in the direction that the crank trigger wheel rotates. To advance the timing, move the pickup holder assembly in the opposite direction of the trigger wheel rotation. Check the air-gap whenever the timing is changed.

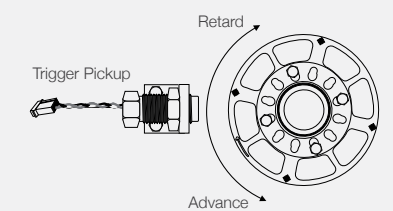

Note: Do not attempt to adjust the timing while the engine is running.

Distributor Caps

Ensure that you have the finest distributor cap available by using one of these Speedmaster™ distributor caps. They're designed with performance in mind, are molded from a high-quality, voltage-insulating material, and use low-resistance terminals for maximum conductivity .

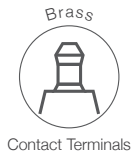

Application	Ref.	Cap Style	Attachment Style	Cap Color	Notes	SKU
6000 Series 6-Cylinder	-	Male/HEI	Clamp down	Black	-	PCE371.1032
				Red	-	PCE371.1001
				Blue	-	PCE371.1033
6000 Series	a.	Male/HEI	Clamp down	Black	-	PCE371.1005
				Red	-	PCE371.1003
				Blue	-	PCE371.1004
				Clear	-	PCE371.1002
				Brown	-	PCE371.1006
				Red	-	PCE371.1007
				Black	-	PCE371.1009
Thunder Series	b.	Male/HEI	Clamp down	Blue	-	PCE371.1008
				Black	-	PCE371.1009
Magneto Series	c.	Female/Socket	Clip-on	Red	-	PCE371.1031
				Black	Standard	PCE371.1014
				Black	90.2 Diameter	PCE371.1015
				Red	Standard	PCE371.1010
				Red	90.2 Diameter	PCE371.1011
				Blue	Standard	PCE371.1012
				Blue	90.2 Diameter	PCE371.1013
				Black	Standard	PCE371.1020
				Black	90.2 Diameter	PCE371.1021
				Red	Standard	PCE371.1016
Red	90.2 Diameter	PCE371.1017				
7000 & 8000 Series	d.	Male/HEI	Clip-on	Black	Standard	PCE371.1014
				Black	90.2 Diameter	PCE371.1015
				Red	Standard	PCE371.1010
8000 Series M-Style	f.	Male/HEI	Clamp down	Red	Designed for marine use.	PCE371.1027
				Red	-	PCE371.1028
				Red	Crab Style	PCE371.1034
				Blue	-	PCE371.1022
				Black	-	PCE371.1023
				Black	-	PCE371.1025
				Red	-	PCE371.1024
8000 Series M-Style	g.	Male/HEI	Screw down	Red	-	PCE371.1027
				Red	-	PCE371.1028
				Red	Crab Style	PCE371.1034
9000 Series	i.	Male/HEI	Clip-on	Blue	-	PCE371.1022
Pro OEM Series	j.	Male/HEI	Clamp down	Black	-	PCE371.1023
Pro OEM Series Chevrolet 8-Cylinder	k.	Male/HEI	Screw down	Black	-	PCE371.1025
Pro OEM Series Chevrolet 6-Cylinder	-	Male/HEI	Screw down	Red	-	PCE371.1024

Distributor Coil Covers

Speedmaster™ dust covers are direct replacements for your stock HEI distributor caps. They're designed to be installed with no modifications.



Ref.	Application	Cover Color	SKU
a.	6000 Series	Black	PCE374.1006
		Red	PCE374.1004
		Blue	PCE374.1005
		Clear	PCE374.1002
b.	6000 Series	Red	PCE374.1003
		Black	PCE374.1009
c.	Thunder Series	Red	PCE374.1007
		Blue	PCE374.1008

Distributor Rotors

Speedmaster™ distributor rotors are molded from high-quality, voltage-insulating alkyd materials to resist carbon tracking, while ensuring that the ignition spark reaches the spark plug terminals. For optimum voltage-carrying capabilities, the rotor tips are made from low-resistance brass.



Ref.	Application	Rotor Color	SKU
a.	6000 Series	Red	PCE375.1001
		Blue	PCE375.1002
		Black	PCE375.1003
b.	7000, 8000's & All-Electronic Series	Red	PCE375.1004
		Blue	PCE375.1005
c.	8000 Series M-Style (No Vacuum)	Black	PCE375.1006
		Red	PCE375.1009
d.	8000 Series M-Style (w/ Vacuum)	Black	PCE375.1012
e.	9000 Series	Blue	PCE375.1007
f.	Por OEM Series	Red	PCE375.1008
g.	Pro OEM Series Chevrolet 8-Cylinder	Black	PCE375.1010
h.	Pro OEM Series Chevrolet 6-Cylinder	Black	PCE375.1011

Distributor Cap and Rotor Kits

The cap and rotor of any ignition system must be considered maintenance items. Just like when you change the oil and filter in your car, you should always replace your cap and rotor as a set. Speedmaster™ makes it easy with these cap and rotor replacement kits. The correct rotor is already matched to the correct cap for you.



Ref.	Application	Cap Color	SKU
a.	6000 Series	Black	PCE370.1004
		Red	PCE370.1002
		Blue	PCE370.1003
		Clear	PCE370.1001
b.	Ford EA EB ED EI 6-Cylinder	Black	PCE370.1006
		Red	PCE370.1005
		Grey	PCE370.1007

HEI Distributor Upgrade Kits

These Ultimate HEI kits from Speedmaster™ is a great option to turn your early model GM HEI distributor into a great performance distributor.



Application	Kit Color	SKU
6000 Series	Black	PCE378.1004
	Red	PCE378.1002
	Blue	PCE378.1003
	Clear	PCE378.1001

Ignition Components

Distributor Replacement Parts

Pickups

Speedmaster™ pickups are the same high-output assemblies that are currently found in Speedmaster™ distributors. They're made to replace defective or damaged pickups.



Ref.	Application	Replacement Part Type	SKU
a	6000 Series	Magnetic pickups	PCE374.1026
-	6000 Series 6-cylinder	Magnetic pickups	PCE374.1024
b.	7000 Series	Magnetic pickups	PCE374.1012
c.	8000 and 9000 Series	Magnetic pickups	PCE374.1013
d.	8020 Series	Magnetic pickups	PCE374.1014
e.	10000 Series	Hall Effect Pickup	PCE374.1015

Vacuum Advance Canisters

Speedmaster™ vacuum advance canisters will allow you to replace or upgrade your vacuum advance unit on your Speedmaster™ distributor. These canisters are made from high-quality materials to ensure optimum performance.



Ref.	Application	Notes	SKU
a.	6000 Series	-	PCE374.1019
b.	7000 Series	Clockwise Rotation	PCE374.1020
c.	7000 Series	Counter-Clockwise Rotation	PCE374.1021

Harnesses

Speedmaster™ replacement distributor harnesses are designed to replace the wiring harness from your Speedmaster™ distributors.



Ref.	Application	Part Type	SKU
a.	Holden Series 2 EFI	Harness	PCE374.1010
b.	Ready-to-Run	Harness	PCE374.1029
c.	6000 Series	Harness & Capacitor	PCE374.1027

Reluctors

Speedmaster™ replacement distributor reluctors will fit your Speedmaster™ distributors. They are made up of a special material to pick up the signal inside of the distributor.



Ref.	Application	SKU
-	6000 Series 6-cylinder	PCE374.1025
a.	7000 Series	PCE374.1022
b.	8000 Series	PCE374.1023
c.	6 Cylinder Pressed Tin	PCE374.1017
d.	8 Cylinder Pressed Tin	PCE374.1018

Advance lockout

Speedmaster™ advance lockouts are designed to easily remove the vacuum advance chamber from Speedmaster™ 6000 series distributors that use a clockwise rotation. They are made of plastic and feature a black finish. No modifications are required to install the advance lockouts.



PCE369.1002

Advance Curve Kit

Speedmaster™ curve kits allow your distributor to reach full advance more quickly, delivering maximum power and engine acceleration. Includes (3) advance stop bushings. This Advance Curve Kit will work with all GM and aftermarket HEI distributors.



PCE369.1001

Replacements



Ref.	Application	Part Type	Notes	SKU
a	6000 Series	Carbon button	Cap Carbon Bush	PCE374.1028
b.	7000 Series	Module Cover	Chrome	PCE374.1016
c.	Ford 302W to 351W & 351C	Sleeve	-	PCE374.1011

Distributor Gears

Iron

Match your camshaft with Speedmaster™ iron distributor gears. These small gears have a big impact on your engine's performance. Best suited for hydraulic or solid flat tappet camshafts, our iron distributor gears are the perfect mates for your cast iron cams. The right choice is critical for your engine and your wallet--choose Speedmaster™ iron distributor gears. They are manufactured from top-quality cast iron, and then nitrided for durability.



Application	Notes	SKU
Chevrolet SBC 350 BBC 454	0.491" diameter shaft.	PCE372.1003
	0.500 in. diameter shaft.	PCE372.1005
Ford SB 289 302 351 Windsor	0.491 in. diameter shaft.	PCE372.1007
	0.500 in. diameter shaft.	PCE372.1009
	0.531 in. diameter shaft.	PCE372.1011
Ford 302 351C Cleveland 460	0.500 in. diameter shaft.	PCE372.1013

Aluminum/Bronze

Bronze distributor gears from Speedmaster™ are recommended for steel billet mechanical roller tappet cams and slot hard-faced steel billet mechanical flat tappet cams. Bronze gears absorb the increased wear in special cams and magnetos and are easily replaced before costly damage to the camshaft gear occurs. The gears are precision-machined from the highest quality aluminum silicon bronze alloy for maximum durability. Bronze distributor gears must be checked often and replaced as needed.



Application	Notes	SKU
Chevrolet SBC 350 BBC 454	Reverse Rotation, 0.491 in. diameter shaft.	PCE372.1001
	0.491" diameter shaft.	PCE372.1002
Ford SB 289 302 351 Windsor	0.500 in. diameter shaft.	PCE372.1004
	0.491 in. diameter shaft.	PCE372.1006
Ford 302 351C Cleveland 460	0.500 in. diameter shaft.	PCE372.1008
	0.531 in. diameter shaft.	PCE372.1010
Mopar Chrysler SB 318 340 360	0.500 in. diameter shaft.	PCE372.1014

Distributor Hold-Down Clamps

Since you're installing that new distributor, you'll need to hold it down with something. Why not use Speedmaster™ distributor clamps? Made from top quality materials, they're the perfect way to dress up your engine compartment. They may include the clamp, stud, nut, and washer.



Ref.	Application	Hold-Down Material	Hold-Down Finish	Fastener Style	SKU
a.	Chevrolet SBC 350 BBC 454	Aluminum	Chrome	Stud	PCE373.1002
			Red		PCE373.1003
			Blue		PCE373.1004
			Silver		PCE373.1005
b.	Holden 253 304 308	Steel	Chrome	Stud	PCE373.1001
			Silver		PCE373.1007
c.	Ford SB 289 302 351 Windsor 351C	Steel	Chrome	Bolt	PCE373.1006

Ignition Components

Electronic Distributor Conversion Kits

This kit replaces the existing points and condenser on most Speedmaster™ models, with a new reliable electronic module. The electronic ignition module has been developed to work with the standard ignition coil and provides service free and accurate ignition timing. The kit can be easily fitted to standard points type distributors without having to fit a new electronic coil.



Ref.	Trigger Style	Ground	Advance Type	Rev Limiter	Volts	SKU
a.	Hall effect	Negative	Vacuum and mechanical	Yes	12 V	PCE377.1001
b.	Optical	Negative	Vacuum and mechanical	No	12 V	PCE377.1002

Ignition RPM Module Kits

Tune your rpm-activated control to your application with one of these Speedmaster™ rpm module kits. The kits include five modules in 200 rpm increments.



RPM Module Range	SKU
5,000 to 5,800 rpm	PCE384.1001
6,000 to 6,800 rpm	PCE384.1002
7,000 to 7,800 rpm	PCE384.1003
8,000 to 8,800 rpm	PCE384.1004

Ignition Modules

Speedmaster™ offers budget pricing and big performance with their ignition controller modules. The modules improve performance with multiple spark, more spark, and ensured combustion for a cleaner burn to set the streets on fire. Speedmaster™ ignition modules will show you the benefits of greater throttle response, smoother idle, and full power output at high rpm. Fire your engine for less with Speedmaster™ ignition controller modules.



RPM Limiters/Selectors

NON CDI Compatible

Speedmaster™ designed these electronic governors with fleet vehicles in mind. Over-revving an engine can be dangerous and expensive, so for fleet vehicles, an easy means of limiting rpm can be crucial. These governors cut spark to different cylinders and then fire them on the next cycle to hold the rpm to your predetermined level, giving you peace of mind, no matter who is driving the vehicles. Installation is simple and the same module can work on 4, 6, or 8-cylinder engines. Don't be worried about what others are doing in your vehicles anymore equip them with these Speedmaster™ electronic governors to protect your investments.

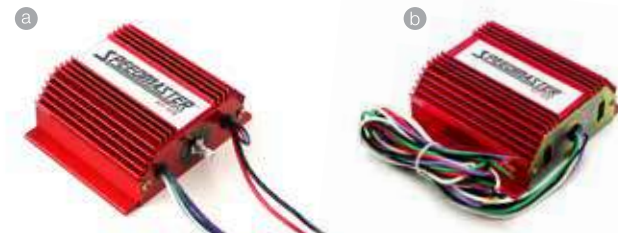

Ref.	Type	CDI Compatible	Requires RPM Module	SKU
a.	Single RPM Limiter Safety	No	No	PCE386.1001
b.	Dual Step Module Selector	No	Yes	PCE386.1002
c.	Three Step Module Selector	Yes	Yes	PCE491.1001

CDI Compatible

Speedmaster 3-step module selectors are designed for great versatility. They feature three built-in rev limiters one for burnout, one for starting line launch, and one for high end.

Note: Unit requires CDI ignition with module input to work.



Tachometer Adapters

Speedmaster™ Tach Adapter are designed to correct the operation of most voltage triggered tachometers that do not work directly off the tach read output on aftermarket ignition boxes.

Note: Not for use with CDI Units

Ref.	Type	SKU
a.	Points Ignition	PCE387.1001
b.	Magnetic Pickup	PCE387.1002

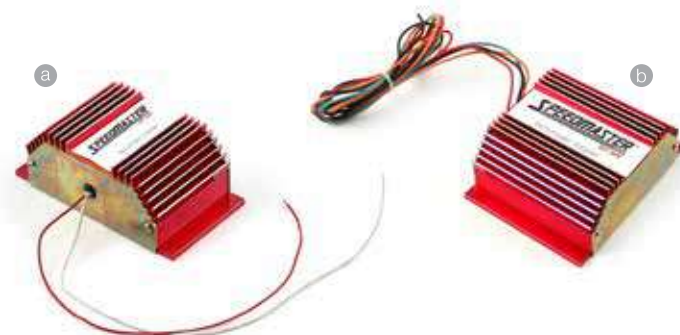

Ref.	Application	Module Pin Quantity	Wiring Harness Included	Notes	SKU
a.	6000 Series	4	No	Magnetic Pickup	PCE383.1001
b.	6000 RPM Series	-	Yes	RPM	PCE383.1016
c.	6000 Plus Series	4	Yes	Magnetic Pickup	PCE383.1006
d.	6000 Plus Series	4	Yes	Magnetic Pickup - Soft Rev Limiter	PCE383.1007
e.	Magneto Series	2	No	Magnetic Pickup	PCE383.1005
f.	7000 Series	4	No	Magnetic Pickup	PCE383.1002
g.	7000 Series	4	No	Hall Effect Pickup	PCE383.1009
h.	7000 RPM Series	-	Yes	RPM	PCE383.1017
i.	8020 Series	2	No	Magnetic Pickup	PCE383.1003
j.	Chevrolet OEM Series	2	No	Magnetic Pickup	PCE383.1008
k.	Chevrolet TPI TBI OEM Series	2	No	Magnetic Pickup	PCE383.1010
l.	Ford OEM Series	3	No	Hall Effect Pickup	PCE383.1004
m.	Holden 304 VN VP Series 1 DFI	-	-	-	PCE383.1014
m.	Holden 304 VN VP VR VS VT VY Series 2 DFI	-	-	-	PCE383.1012
				Natural	PCE383.1015
				Black	PCE383.1018
				Blue	PCE383.1019
				Orange	PCE383.1020
n.	Holden Commodore VN VP VR VS VT 304 5.0	6	Yes		

Ignition Boxes

Efficient and Powerful

Achieve increased starting power, complete combustion burns, and greater fuel efficiency with an ignition box from Speedmaster™. We have electronic ignition boxes with rev limiters and both digital and analog circuitry. Explore our large, in-stock selection today for the starting power you need to keep your engine revving drive after drive.

Multi-Spark Inductive Ignition

Speedmaster™ 6A is the entry level multiple spark ignition control. This inductive discharge ignition is designed to be used on stock vehicles with no or minor performance upgrades such as a cam, intake manifold, or carburetor. Below 3,000 rpm, the 6A produces a series of sparks instead of just one that will improve combustion of the fuel mixture resulting in quick starts, smooth idle and increased performance, more power, easier starting, snappy throttle response and increased economy.

NOTE: This ignition will install easily to magnetic pick-up distributors such as our line of Pro-Billet Distributors.



Output	Spark Output	Primary Voltage	Secondary Voltage	RPM Range	Voltage Required	Circuitry	Rev Limiter	Timing Retard	Data Acquisition	SKU
Inductive	180 mJ	420 - 450 Volts	40,000 Volts	10,000 RPM (8-Cyl)	12 Volts, Negative Ground	Analog	No	No	No	PCE380.1001



Quick Tip

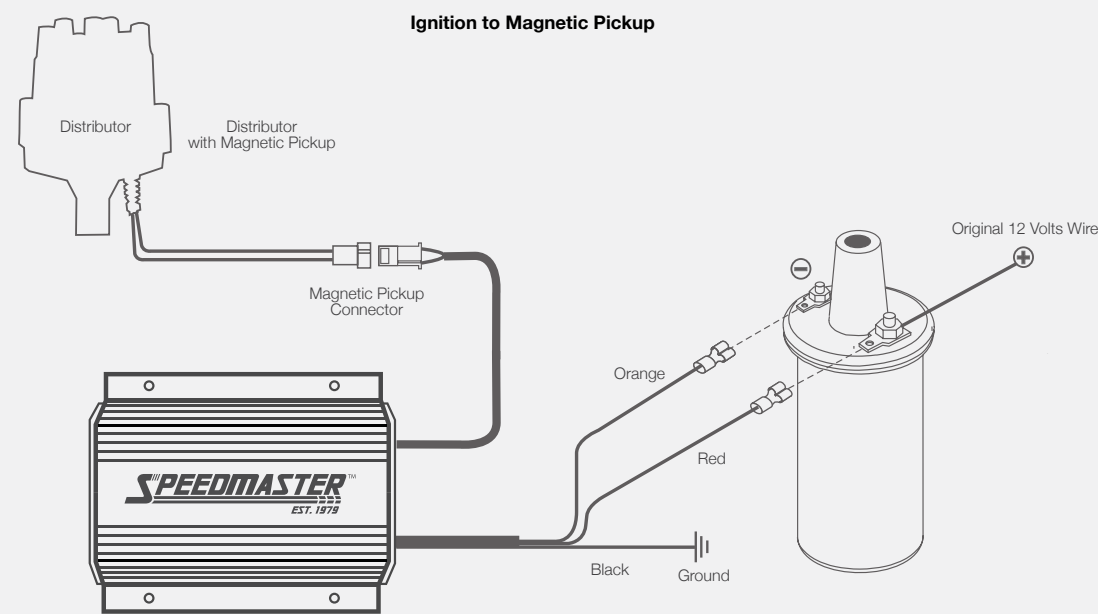

Note: Check the polarity of the magnetic pickup wires of the distributor. Reverse the connectors and check the timing again. The correct polarity is whichever connection gives the most retarded timing.

Multi-Channel Inductive Ignition

Speedmaster™ Multi Channel Ignition Controls are designed for engines with coil pack or waste spark ignition systems. Designed to fire up to four coil packs (or even four individual coils). Each Control delivers full power Capacitive Discharge sparks from idle through racing rpm. Below 3,000 rpm there is a series of multiple sparks that last for up to 20° of crankshaft rotation to improve idle, starting and throttle response.

The adjustable features of the distributor less Ignitions are made with easy to adjust rotary dials. These provide easier, and more precise adjustments of the rev limiter and the staging rev limit. PCE380.1002 & PCE380.1003 are equipped with a step retard that can be wired directly to a nitrous system or switch for activation. For use on 6 or 8-cylinder engines with two, three or four coil packs.

The PCE380.1003 Ignitions produce an incredible 170 millijoules of spark energy with 470 primary volts. This increased output will light up fuel mixtures even under extreme cylinder pressures in such applications as full bred race engines running high combustion pressures from turbos, blowers or nitrous.

- 2,4,6,8 Cylinder application
- Multiple coil output
- Works with 2, 3 and 4 DIS inputs and outputs.
- Operates on 12-18 volts
- Tach output is 12v square wave 40 degree duration
- Works on standard (single tower coil) and wasted spark (dual tower coil pack) systems.
- Multiple sparks (12) per cycle over 20 degrees of crankshaft rotation up to 3,000 RPM.
- The factory RPM limiter and timing functions will function as normal with this box.
- Spark retard in 1 degree increments**
- Delay retard off setting available. Retard off can be delayed 1 second to allow engine to clear nitrous mixture.**
- 2 RPM limiters high and low settings. Adjustable in 100 RPM increments.**
- Plus 4K or zero RPM limiting. Either adds 4,000 rpm to maximum limit you set or leaves it where you set it.**
- Non emission legal

**NOTE: Does not apply to PCE380.1004

Ignition Box Output	Circuitry	Rev Limiter	Timing Retard	CD Voltage Output to Coil	Spark Output	SKU
Capacitive discharge	Digital	Yes - Two	One-stage	470 V	115 Millijoules	PCE380.1002
Capacitive discharge	Digital	Yes - Two	One-stage	470 V	170 Millijoules	PCE380.1003
Capacitive discharge	Digital	No	No	535 V	200 Millijoules	PCE380.1004

Quick Tip



Programming Rotary Switches

The Multi-Channel Ignitions provide several programmable features that are set using the seven rotary dials on their end panel. They are programmed at the factory for operation on most 4, 6 or 8-cylinder engines with distributorless ignitions.

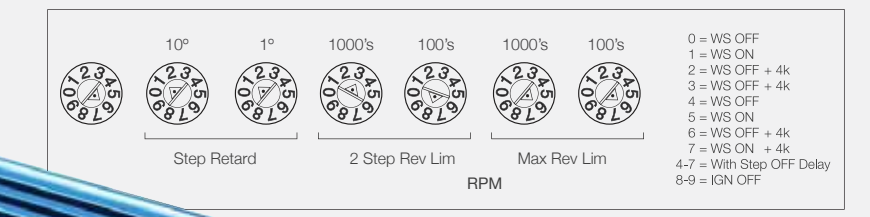

6AL CDI Ignition

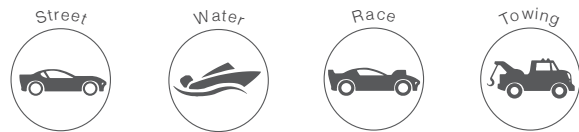

The entire line of Speedmaster™ Ignitions is the most popular aftermarket ignition in the world due to our race-proven performance on and off the track. The increased voltage that the 6AL unit puts across the plug gap will improve the driveability and performance of everyday drivers to Saturday night racers! The 6AL Ignition can be installed on 4, 6 or 8-cylinder engines equipped with a 12 volt, negative ground electrical system and a distributor. They can be triggered by points, electronic amplifiers, magnetic pickups and other aftermarket distributors.

Speedmaster™ 6AL uses capacitive discharge (CD) technology to produce a very high primary voltage. This high voltage is always present regardless if you're at idle or racing down a straight away at 10,000 rpm. The high quality transformer is hand wound and instantly steps up the supply voltage from the battery then stores this high voltage in a large capacitor. When the ignition is triggered the capacitor releases all of this voltage to the coil so the primary voltage is at full power at any rpm. These high powered sparks ensure complete combustion of the fuel mixture at racing rpm which in turn produces more power!

Speedmaster™ 6AL Ignitions produce multiple sparks up to at least 3,000 rpm. This series of sparks (each spark is at full voltage), whether there are two or six, will always last for 20° of crankshaft rotation. This powerful series will improve the starting ability, idle quality & throttle response. If you have a multiple carb set up that is a little off at idle or an engine that burns a little oil, the spark series will help prevent the cylinders loading up. At higher rpm there isn't enough time to fire the plug more than once during the combustion stroke so there is only a single full power spark. With the Speedmaster™ 6AL CD technology, this spark is always at full power even through 10,000+ rpm so you know the fuel mixture is being burned efficiently, creating maximum power!

Speedmaster™ 6AL Soft Touch circuitry produces an accurate and smooth limit without loading up the cylinders or excessive back fires. Even if your car is a mild street machine, a rev limiter can save you from expensive engine damage due to driveline failure or a missed shift.

You can run a Speedmaster™ 6AL Ignition with your stock distributor, then upgrade to a Pro-Billet model or even a crank trigger. You don't have to buy everything at once or spend money on features that you will never use.



Ref.	Box Finish	SKU
a.	Smooth Red	PCE380.1005
	Finned Top Red	PCE380.1012
	Finned Case Red	PCE380.1013
	Heat Sink Red	PCE380.1014
b.	Smooth Top	PCE380.1006
	Heat Sink Red	PCE380.1016
	Heat Sink Black	PCE380.1008
c.	Heat Sink Red	PCE380.1007
	Smooth Top	PCE380.1009
	Heat Sink Red	PCE380.1015

Output	Spark Output	Primary Voltage	Secondary Voltage	Spark Series Duration	RPM Range	Voltage Required	Current Draw
Capacitive discharge	110-115 mJ /Spark	460-490 Volts	45,000 Volts	20° Crankshaft Rotation	15,000 RPM (w/14.4 Volts)	12-15 Volts	1 Amps @ 1,000 RPM

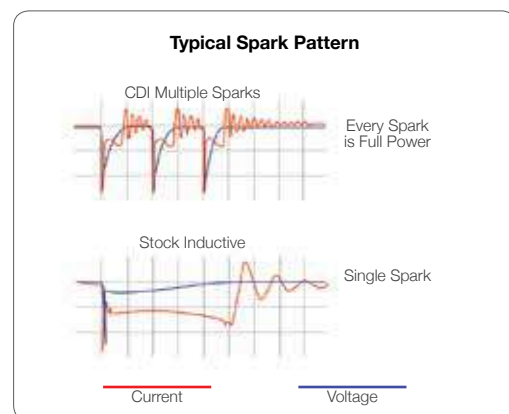
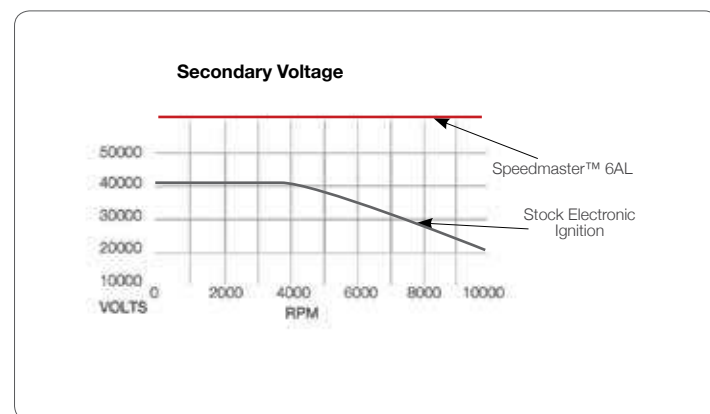

Race CDI Ignition

The RACE CDI is the most powerful ignition of its type and is to be used for RACE USE ONLY. The entire line of Speedmaster™ Ignitions are the most popular aftermarket ignition in the world due to our race-proven performance on and off the track. The 7AL Ignition can be installed on 4, 6 or 8-cylinder engines equipped with a 12 volt, negative ground electrical system and a distributor. They can be triggered by points, electronic amplifiers, magnetic pickups and even other aftermarket distributors.

Speedmaster™ uses capacitive discharge (CD) technology to produce the highest primary voltage in the Speedmaster™ range. This high voltage is always present regardless if you're at idle or racing down a straight away at 10,000 rpm. The high quality transformer is hand wound and instantly steps up the supply voltage from the battery then stores this high voltage in a large capacitor. When the ignition is triggered the capacitor releases all of this voltage to the coil so the primary voltage is at full power at any rpm. These high powered sparks ensure complete combustion of the fuel mixture at racing rpm which in turn produces more power!

Speedmaster™ Ignitions produce multiple sparks up to at least 3,000 rpm. This series of sparks (each spark is at full voltage), whether there are two or six, will always last for 20° of crankshaft rotation. This powerful series will improve the starting ability, idle quality & throttle response. If you have a multiple carb set up that is a little off at idle or an engine that burns a little oil, the spark series will help prevent the cylinders loading up. At higher rpm there isn't enough time to fire the plug more than once during the combustion stroke so there is only a single full power spark. With the Speedmaster™ RACE CDI technology, this spark is always at full power even through 10,000+ rpm so you know the fuel mixture is being burned efficiently, creating maximum power!

Speedmaster™ DUAL Easy Touch circuitry produces an accurate and smooth limit without loading up the cylinders or excessive backfires. Even if your car is a mild street machine, a rev limiter can save you from expensive engine damage due to driveline failure or a missed shift.

The Speedmaster™ Coil utilizes a unique Internal Core design for unparalleled voltage distribution. This unique Core design has incredible dielectric capabilities at high temperatures, and incorporates a cutting edge winding material that has an improved insulation and is also capable of enduring extreme voltages delivering lightning quick rise time and lengthy spark duration. The housing is completely potted with an epoxy compound for vibration resistance and installs with any vibration mounts. You can run a Speedmaster™ Ignition with your stock distributor, then upgrade to a Pro-Billet model or even a crank trigger. You don't have to buy everything at once or spend money on features that you will never use.

Output	Spark Output	Primary Voltage	Secondary Voltage	Spark Series Duration	RPM Range	Voltage Required	Current Draw	Box Color	SKU
Capacitive discharge	135 mJ /Spark	520 Volts	46,000 Volts	20° Crankshaft Rotation	14,000 RPM (w/14.4 Volts)	12-18 Volts	6 Amps @ 6,000 RPM 12 AMps @ 12,000 RPM	Gold Red	PCE380.1010 PCE380.1011

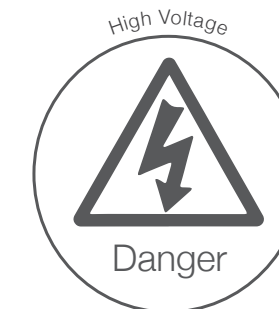

Ignition Coils

Caution: High Voltage!

Caution: high voltage! Our line of direct-fit and universal ignition coils delivers the voltage you need for increased performance on the street, track, or trail. Choose from canister, coil pack, E-core, magneto, and in-cap designs built to give your ignition system an added punch! Don't let weak spark derail your vehicle's performance—crank up the juice with a powerful ignition coil from Speedmaster.

In Cap Epoxy

Speedmaster™ HEI Coils are one of the most powerful coils, producing 50,000 volts, and still able to fit under your stock HEI Cap.

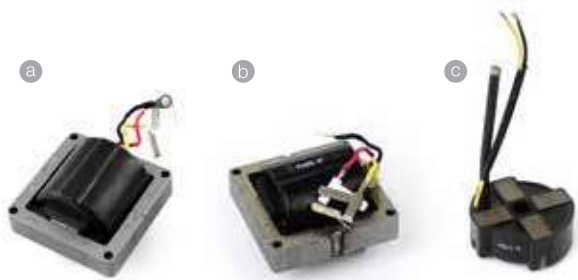

Canister Oil-filled

Speedmaster™ Oil Filled heavy duty coils are guaranteed to out perform your stock unit delivering over 30% more spark energy. The Oil Filled design and arc resistant top, results in superior performance. The Coil delivers the added voltage required by street and strip performance engines, and will fit in most standard OEM brackets.



Coil Pack Epoxy

If you're still running stock coils on your car, you could be missing out on extra horsepower, and you're not getting the best fuel mileage or throttle response. Our direct replacement coil pack ignition coils increase power to the spark plug significantly when compared with stock coils.



C-Core Epoxy

Speedmaster™ Transformer Ignition coils are Epoxy filled eliminating internal vibration, oil leaks and producing 50% more spark than stock. Universal mounting brackets make it easy to replace as it suits most vehicles.



High Output Epoxy

The Speedmaster™ high output technology coil produces up to 70% more spark energy than stock coils with outstanding reliability. This unit is recommended for street, strip, circle track and drag racing. Internally the coil also has large gauge wire windings for maximum spark current and voltage with better heat dissipation at high rpm. High voltage arcing is minimized through screw on connectors and a high tension tower. Ideal for use with capacitive discharge (CD) ignition systems and all of Speedmaster™ range of High Output Ignitions.



- | | | | | | |
|----------------------------|---|---|--|--|--|
| a. PCE382.1021 HEI 50k | e. PCE382.1016 Female Chrome
PCE382.1001 Chrome w/ Resistor
PCE382.1015 Black | h. PCE382.1024 LS1 LS6 Female
PCE382.1025 Set of 8 | l. PCE382.1013 Screw Terminal Female | q. PCE382.1020 PC92 Male | t. PCE382.1035 Round Male Red
PCE382.1037 Blue
PCE382.1036 Black |
| b. PCE382.1022 HEI 35k | f. PCE382.1019 Super - Yellow | i. PCE382.1003 DIS Male | m. PCE382.1012 Screw Terminal Male | r. PCE382.1023 Blaster SS Male | u. PCE382.1005 HPC Male Red
PCE382.1006 Blue |
| c. PCE382.1002 Magneto HEI | g. PCE382.1032 LS Female | j. PCE382.1017 Ford 4.6L EFI Red
PCE382.1039 Set of 8 | n. PCE382.1010 Screw Term. Male w/Brakets | s. PCE382.1033 Classic Male Red
PCE382.1026 Chrome
PCE382.1030 Black
PCE382.1007 PCE Red
PCE382.1008 PCE Blue
PCE382.1009 PCE Black | |
| d. PCE382.1014 Male Black | | k. PCE382.1031 Ford 4.6 5.4L Yellow
PCE382.1038 Set of 8 | o. PCE382.1004 Plug Terminal Male | | |
| | | | p. PCE232.1011 Plug Terminal Male w/Brackets | | |

Spark Plug Wire Sets

10.5mm | Spiral Wound Core

Get more spark from your plugs with a set of Speedmaster™ ignition wires. These 10.5mm wires feature high-temperature 100% pure silicone insulator outer layer! Their spiral-wound copper conductor has extremely low resistance combined with extremely high EMI suppression. In plain terms, these wires deliver the highest possible energy to the spark plugs so that your ignition upgrades reach their full potential, without creating interference for onboard electronics. The wires have a high dielectric strength insulator and heavy glass braid, topped with heavy-duty black silicone jackets and high-temperature black boots to resist damage from heat and abrasion.



Direct-Fit

Speedmaster™ Direct-Fit are designed to eliminate the guesswork of finding the correct length wires to fit your engine!

Application	Distributor Terminal Ends	Notes	Wire Color	SKU
Universal 90-90	Female/Socket	Over the covers.	Red	PCE390.1001
			Blue	PCE390.1002
			Black	PCE390.1003
	Male/HEI	Under the covers.	Red	PCE390.1007
			Blue	PCE390.1008
			Blue	PCE390.1009
Universal 90-STR	Female/Socket	Over the covers.	Red	PCE390.1004
			Blue	PCE390.1005
			Black	PCE390.1006
	Male/HEI	Under the covers.	Red	PCE390.1010
			Blue	PCE390.1011
			Black	PCE390.1012
GM LSX STR-STR	Stock	-	Red	PCE390.1019
			Blue	PCE390.1020
			Black	PCE390.1021
			Black	PCE390.1024
GM LSX 45-STR	Coil pack	-	Red	PCE390.1026
			Black	PCE390.1028

Custom-Build

If you have a muscle car that has an engine swap under the hood, finding the perfect spark plug wires to fit your Frankenstein ride can be a big challenge or for those who love customization Speedmaster™ has a full line of universal wire kits that allow you to cut and crimp the wires to the length you need.

Application	Distributor Terminal Ends	Wire Color	SKU
Universal 90-90	Male/HEI	Red	PCE390.1013
		Blue	PCE390.1014
		Black	PCE390.1015
		Black	PCE390.1018
Universal 90-STR	Male/HEI	Red	PCE390.1016
		Blue	PCE390.1017
		Blue	PCE390.1017
		Black	PCE390.1018



Features

Professional-grade silicone rubber outer jacket shields against chemicals, heat, moisture and gas. Remains flexible in most engine operation conditions.

High-dielectric strength Ethylene Propylene Diene Copolymer Compound (EPDM) eliminates voltage leaks and radio frequency interference (RFI).

The ferromagnetic compound absorbs the interferences 4 + 5. Perfect suppression all along the cable.

Woven fiberglass reinforced braid allows for superior pull strength between extrusions.

A synthetic string supports the ferromagnetic compound.

Stainless steel conductor spirally wound around the ferromagnetic compound, with 50 non-touching spirals per centimeter, to ensure high tension current conduction and canalizes the magnetic field induced in the core of the cable. Greater ignition current and longer spark duration.

Quick Tip



Standard Application Angles:

Engine Make	Distributor Cap End	Spark Plug End
Chevrolet SB	90	90
Chevrolet BB	90	90
Holden	90	Straight
GM LS	45	Straight(LS Specific)
Ford SB Windsor	90	90
Ford Cleveland	90	Straight
Chrysler	90	Straight

Type of Spark Plug Wire Ends



Spark Plugs

Speedmaster™ copper core spark plugs feature a cold-formed steel shell with precision-rolled threads, a full copper core electrode to provide better performance, triple-ground electrode for more efficient combustion and a one-piece terminal post to add strength. Speedmaster™ copper core spark plugs use a copper-glass seal that bonds the insulator and terminal post center electrode together. This ensures full voltage at the spark gap and a 100 percent leak-proof, gas-tight seal. Keep your engine running smoothly and reliably with Speedmaster™ copper core spark plugs.



Resistor	Electrode Core Material	Electrode Tip Material	Insulator Type	Spark Plug Thread Size	Spark Plug Reach	Spark Plug Seat Style	Wrench Diameter	Ground Strap Quantity	Quantity	SKU
Yes	Copper	Copper	Projected	14mm	0.708 in.	Tapered	5/8 in.	Three	Set of 4	PCE444.1001
									Set of 8	PCE444.1002

Ignition Wire Looms & Separators

Dress up your engine compartment and organize your plug wires all in one fell swoop with these Speedmaster™ billet wire looms. Their stout aluminum construction showcases a mirror-polished finish and either plain or various machined top designs. Their 2-piece design features adjustable tabs that attach to the base of the valve covers via their mounting bolts.



Ref.	Application	Wire Separator Material	Wire Separator Finish	Plug Wire Attachment Style	Bracket Attachment Style	Wires Per Separator	Wire Separator Logo	SKU
a.							Ball-milled	PCE388.1010
b.	Universal	Aluminum	Polished	Clamp-in	Valve cover bolts	1, 2, 3, 4	Flames	PCE388.1011
c.							None	PCE388.1012
d.	Universal	Plastic	Chrome Black	Clamp-in	-	2, 3, 4	-	PCE388.1008 PCE388.1009
e.							Ball-milled	PCE388.1004
f.	Chevrolet SBC 350 Late	Aluminum	Polished	Clamp-in	Valve cover bolts	1, 2, 3, 4	Flames	PCE388.1005
g.							Horizontal	PCE388.1006

Battery Boxes

Give your battery extra protection and reduce underhood clutter with Speedmaster™ rugged fabricated aluminum battery boxes. Fabricated aluminum boxes feature a sealed design with an external vent tube. They come complete with hold-downs, hold-down brackets, and high grade nuts.



PCE361.1001 Universal Fabricated Polished Aluminum

Battery Trays

These stainless steel battery trays from Speedmaster™ are a great place to put your battery. They come with a chrome hold-down.



PCE362.1001 Universal Stainless Steel 7.5 in. x 13.25 in.

Alternators

High Output

Your engine runs on air, fuel and spark. The spark is the center of it all, and for that we need electricity. Your battery supplies electricity, but only enough to get you a few miles down the road. We need more. That's where the alternator comes in. The alternator continually charges the battery so that we never have to worry about that whole "running out of juice" problem. They also provide power to operate your electric accessories while your car is running.

Speedmaster™ High Output Alternators allow more current to be created by a higher output therefore minimizing the strain on your battery. Speedmaster™ combine reliable amperage with stunning good looks. They come completely assembled, ready to bolt on. Speedmaster™ parts are selectively tested with acid spray machines to verify corrosion resistance, and with de-plating equipment to measure plating thickness. They are available in multiple finishes and applications. They look great in any engine compartment, while providing the power you need to run your accessories. For high-quality, great looking alternators, you can count on Speedmaster™.

Speedmaster™ Alternator Benefits

- Handle high electrical demands
- Provide enough power without depleting the battery
- Minimize the strain on your battery
- Compact and lightweight design

55% More power than stock alternators



Speedmaster™ Alternator Types

Speedmaster™ offers two main types of alternators that GM originally designed. The 1-wire, which is great choice for a clean setup and easy installation and the 3-wire OEM-style replacement.



1-Wire

A 1-wire alternator offers a simplified installation and clean setup. It has one wire that connects the charge terminal directly to the battery or a 12V source. They are internally regulated and grounded through the block. 1-wire alternators will not have a way to hook up a warning light, but most custom applications work well with a voltage gauge in its place. The cut in speed (the speed at which the regulator begins to charge) will be slightly higher (1200rpm or higher) than most alternators which means they do not charge at idle.



3-Wire

A 3-wire or "OEM-style" alternator will also be internally regulated and have a charge post and two terminals on the side (viewed from back). Typically the left terminal is for the field or exciter circuit and the right terminal is used for the sensing circuit. They are slightly more complicated to wire up, but have the advantage of charging at lower rpm and the ability to use an original warning light.



a.	PCE360.1001 Universal 1 Wire 100Amp Chrome	e.	PCE360.1006 GM RH Mount Serpentine 130Amp
	PCE360.1003 Polished	f.	PCE360.1007 GM LH Mount Serpentine 130Amp
	PCE360.1004 Satin	g.	PCE360.1008 Universal Serpentine 130Amp
b.	PCE360.1009 Universal 3 Wire 100Amp Chrome		
c.	PCE360.1010 Universal 1 Wire 120Amp Chrome		
d.	PCE360.1002 Universal 1 Wire 100Amp Phenolic Fan		

Starters

Maximum Cranking Power



High Torque gear reduction Starter Motors turn the engine over faster than any stock starters. Producing between 30 - 40% more cranking power Speedmaster™ starter motors also feature an offset design resulting in more clearance between the oil pan and the starter. Start your engines with starters that deliver maximum cranking power! Our lineup includes standard full-size starters for street machines, high-torque and high-compression starters for race engines, and compact mini starters for tight clearances.

Speedmaster™ Starter Benefits

- Maximum cranking torque under all conditions
- Environmentally designed to start in cold and hot weather conditions
- High-voltage tested armature and field coils to ensure reliable performance

Up to **40%** More cranking power

OEM-Compact

Speedmaster™ OEM-Style starters are manufactured from high-quality materials that exceed the factory specifications. They are designed to fit in the factory location and install easily without any modifications. They provide the torque necessary in several applications.



Mini-Muscle +Plus

2.5 HP Motor

Speedmaster™ super mini-muscle have the same distinguishing characteristics as their mini-muscle with additional features such as larger field windings, stronger armature and bigger brushes. These super mini-muscle are 2.5 horsepower motors which deliver about 40 percent more torque.



Starter Motor Spacer

Speedmaster™ aluminum ford starter spacer plate to fit starter to a Manual type engine. The spacer is used to space out the auto starter so it will work on the toplayer bellhousing.



PCE392.1001 Ford 289 302 351 Windsor Cleveland (Auto to Manual)

Starter Motor Shim Kits

Speedmaster™ starter shim kits are designed to ensure that you have the proper gap between the starter and flywheel. These kits help to eliminate any noise or unnecessary grinding that may cause your starter to prematurely wear.



Ref.	Application	Starter Bolts Included	SKU
a.	Chevrolet SBC 350 BBC 454	Yes	PCE391.1001
b.	Holden 253 304 308	No	PCE391.1002

Mini-Muscle

1.5 HP Motor

If your application requires more torque and lighter weight this Mini starter from Speedmaster™ is the one for you. Its small size allows you more clearance and offers a high torque 3.75 to 1 gear reduction design that spins engines faster while requiring less amps. Speedmaster™ Mini starters feature a full ball bearing design that can be mounted inversely for great performance under the hood.



Thunder

3.0 HP Motor

Speedmaster™ Thunder Starters are designed to crank over the highest compression engines on a hot day in Death Valley. Not that too many race cars are sitting in Death Valley, but it's good to know that you have the oomph to make it happen. They feature all new components beginning with a 3.0 horsepower motor. This power is used to crank over the reduced 4.4:1 gear set to deliver great torque to the engine's ring gear to get the engine turning.



Starters



Quick Tip

Double Bolt Pattern

Most Chevrolet starters are offered with double bolt pattern to fit 10 in. (153-tooth) & 11 in. (168-tooth).

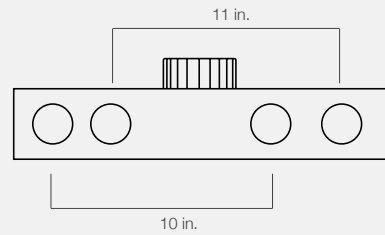

OEM-Compact

Ref.	Application	Notes	Finish	SKU
a.	Chevrolet SBC 350 BBC 454	153-tooth	Red & Gold iridited	PCE393.1001
b.	Chevrolet SBC 350 BBC 454	168-tooth Offset	Red & Gold iridited Chrome Gold iridited	PCE393.1031 PCE393.1003 PCE393.1002
c.	GM LS1 LS2 LS6 LS7	-	Red & Gold iridited	PCE393.1015
d.	Holden 253 304 308	-	Gold iridited	PCE393.1030
e.	Ford SB 289 302 351 Windsor Cleveland	2 Bolt Manual Transmission 2 Bolt Automatic Transmission	Red & Gold iridited Red painted	PCE393.1011 PCE393.1010
f.	Ford 302 Windsor 5.0L EFI Windsor	3 Bolt Automatic Transmission	Red & Gold iridited	PCE393.1009
g.	Ford 6-Cylinder	-	Black & Gold iridited	PCE393.1005
-	Ford 429 460	2 Bolt Automatic Transmission	-	PCE393.1029

Mini-Muscle

Ref.	Application	Notes	Finish	SKU
h.	Chevrolet SBC 350 BBC 454	168-tooth 153-tooth	Black & Gold iridited	PCE393.1004
i.	Chevrolet SBC 350 BBC 454	168-tooth 153-tooth	Black & Gold iridited Chrome Red & Gold iridited	PCE393.1006 PCE393.1007 PCE393.1008

Mini-Muscle +Plus

Ref.	Application	Notes	Finish	SKU
j.	Chevrolet SBC 350 BBC 454	168-tooth 168-tooth Offset	Red painted	PCE393.1016 PCE393.1017
k.	Chevrolet SBC 350 BBC 454	168-tooth 153-tooth	Red painted Blue painted Gold painted	PCE393.1021 PCE393.1022 PCE393.1023
l.	Ford SB 289 302 351 Windsor Cleveland	2 Bolt Automatic Transmission	Red painted	PCE393.1024
m.	Mopar Chrysler SB 318 340 360 383 440	-	Red painted	PCE393.1013
n.	Holden 253 304 308	-	Red painted	PCE393.1012
o.	Harley Davidson	-	Chrome	PCE393.1014

Thunder

Ref.	Application	Notes	Finish	SKU
p.	Chevrolet SBC 350 BBC 454	168-tooth 153-tooth	Chrome Natural	PCE393.1033 PCE393.1032
q.	Chevrolet SBC 350 BBC 454	168-tooth 153-tooth	Chrome Red & Gold iridited Black & Gold iridited	PCE393.1019 PCE393.1018 PCE393.1020
r.	GM LS1 LS2 LS6 LS7	-	Red painted	PCE393.1028
s.	Ford SB 289 302 351 Windsor Cleveland	2 Bolt Automatic Transmission 2 Bolt Manual Transmission	Blue	PCE393.1026 PCE393.1027
t.	FORD FE 390 428	3 Bolt Automatic Transmission	Blue & Natural	PCE393.1025

Wiring Harnesses

Speedmaster™ Universal Automotive Harnesses can be used in just about any vehicle where basic or more wiring is needed. Ample wire lengths make this kit especially suited for everything including trucks with long beds and extra cabs. Applications available in 20 and 22 circuit harnesses. Also available for GM keyed steering columns.

20 and 22 circuit harness kits includes air conditioning, heat, brake lights, coil, horn, electric fan, emergency flashers, dash instruments, headlights, radio (constant and ignition hot), turn signals, wipers, dome light, tail lights, third brake light, charging and starting.

Additionally the 22 circuit harnesses include power door locks, power windows, accessory plug, electric fuel pump, backup lights cruise control, electric choke, and power antenna.



Ref.	Application	Circuit Quantity	Harness Length	Fuse Block Included	Fuse Block Location	Fuse Style	SKU
a.	Universal	20	Ample	Yes	Front	ATO/ATC	PCE368.1001
b.	Universal	22	Ample	Yes	Front	ATO/ATC	PCE368.1002





Air & Fuel Delivery

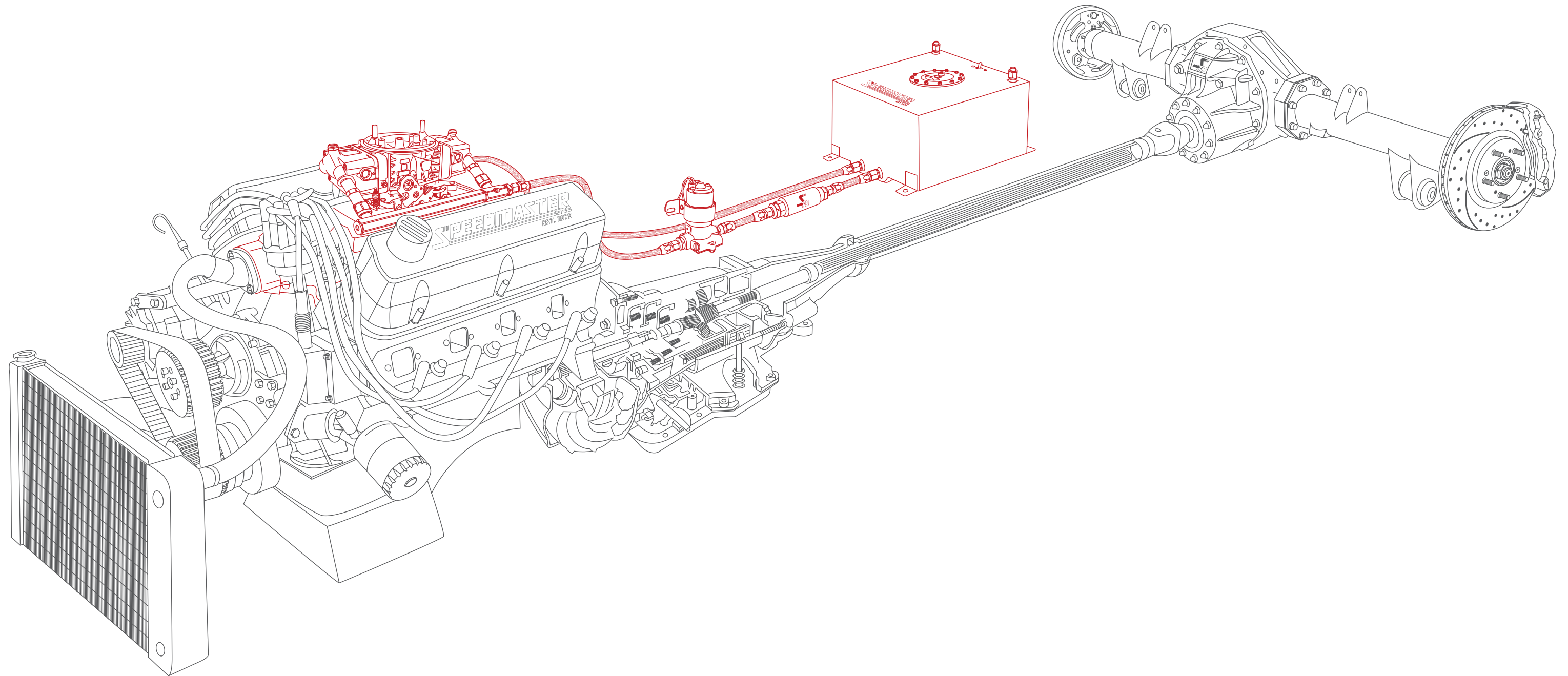

Air and Fuel Delivery (AFD) "Air & Fuel Delivery Parts and Plumbing Department" is a solutions based when it comes to fuel delivery in your car or boat. At Speedmaster™ we manufacture an extensive range of products, from fittings to carburetors, for vehicle applications with outstanding quality and value for money. In doing so, we cater to a broad range of applications, Such as Drag Racing, Hot Rods, Speedway, Marine, Street Applications & Sports Compact. We aim to offer all our customers a Superior product and the most Competitive price on the market.

Intake Manifolds

Take a Deep Breath



Find the Right Fit

Whether you're shopping for a carbureted or fuel-injection intake manifold, consider the following factors:

- Hood clearance
- Cylinder head port design
- Carburetor/throttle body mounting

Your car breathes, just like you do. If a car is like your body, then the intake manifold is its lungs. The intake manifold is a series of tubes that distributes the air coming into the engine evenly to each of the cylinders, so that the right amount of air can mix with the right amount of fuel. During the first stroke (called the intake stroke) air from the intake manifold is sucked into each cylinder through a valve or valves. These intake valves are then closed for the other strokes (compression, combustion and exhaust) and reopen when the cycle starts all over again. It's the intake manifold that's responsible for making sure that there's enough air available when the valve opens for each intake stroke and that each cylinder gets the same amount of air as the others.



Because we know Appearance does Matter

Most Speedmaster™ manifolds are available in four different finishes for the look you want.

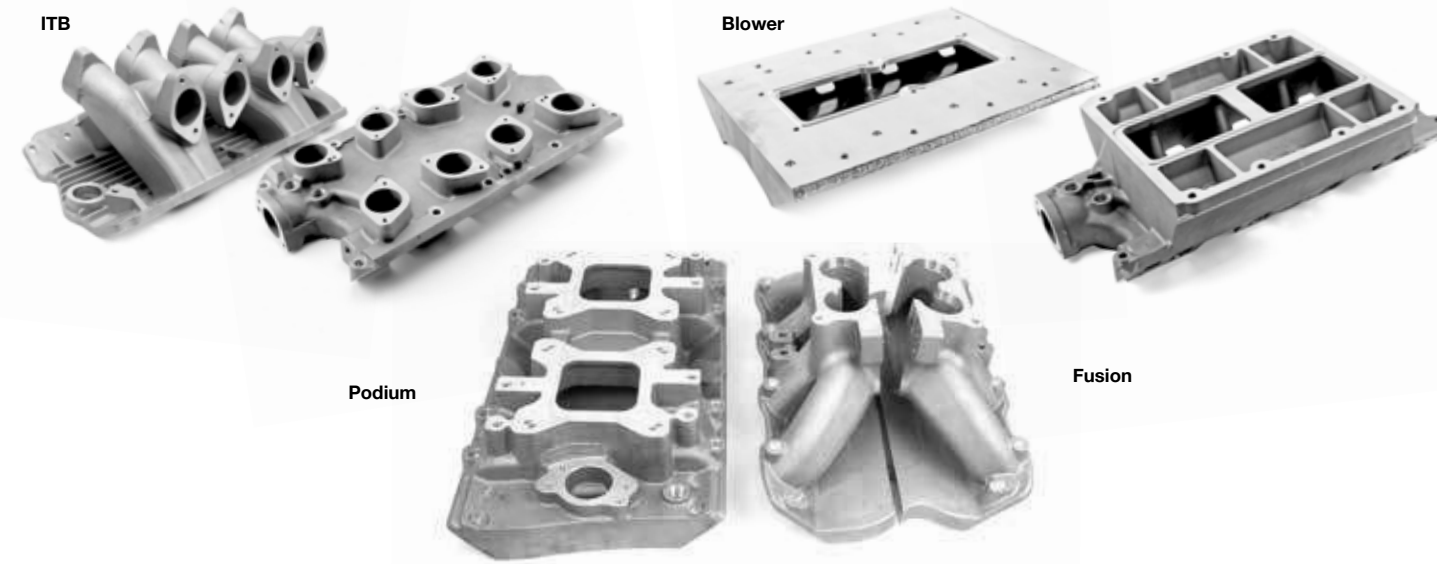

Holeshot

Street Legal

1000-5500
RPM RANGE

Holeshot

The Speedmaster™ Holeshot Manifolds are our lowest profile manifold and is also the only one that is street legal on pollution controlled vehicles. It is set up to accept a spread bore carb but comes with an adapter plate that permits the use of square bore carbs. To remain street legal with a square bore carb, you must use one that is also approved as street legal for your application.

Holeshot +Plus

The terrific Holeshot +Plus is a step up from the Holeshot. Due to its slightly taller height, it can provide more power and torque. It is about 3/8" taller than the Holeshot. It also has a rear water crossover, nitrous bosses and a square bore carburetor flange.

Qualifier

Entry Level

1500-6500
RPM RANGE

The Speedmaster™ Qualifier manifolds, along with the similar eliminator, are the most powerful dual plane manifolds available. For non-pollution controlled street machines, these are among the very best manifolds you can use. They feature a square bore carburetor flange, nitrous bosses, four corner water ports, and dual distributor hold downs. These manifolds are approximately 5/8" taller than the holeshot series. On medium horsepower engines, dyno tests have shown that this manifold comes very close to producing similar power and torque numbers as our shootout racing intake manifold.

ITB

Individual Throttle Body

The Speedmaster™ Individual throttle body EFI system have all the flash of classic Weber induction but provide higher state of tune and engine performance versatility of EFI. Delivering crisp EFI performance with systems capable of supporting up to 1000 hp. Fuel and air is delivered through precision cast aluminum 50mm IDA style throttle bodies that allow for superior idle characteristics and astounding throttle response while improving emissions and economy through tight air/fuel ratio control.

Blower

6-71/8-71 Supercharger

Speedmaster™ 8-71 and 6-71 supercharger manifolds are suitable for competition or street use. They feature heat treated materials, direct 6-71 / 8-71 blower bolt on, will clear distributor (except Hei), raised plenum for better distribution of air, threaded water ports near water outlet.

Eliminator

Air Passage Design

1500-6500
RPM RANGE

The Speedmaster™ Eliminator design features the identical plenum and runner design as the qualifier. The main difference is that there is an open area under the plenum chamber. This feature is sometimes called an air gap design. The air flowing under the plenum provides a cooler charge for the incoming air with less heat transfer from the engine. This cooler air charge provides additional power. The eliminator design is very popular. However, if looks is your main interest, along with more power, the qualifier might be a better choice because it is impractical to polish the open area below the plenum on the eliminator

Shootout

Significant Power

3000-7500
RPM RANGE

Shootout

The Shootout intake manifolds are one of Speedmaster™ very most popular for those looking for the utmost in performance for the very least amount of cost.

Shootout +Plus

The Shootout +Plus which is an improved version of the Shootout. Depending upon exact engine configuration, this manifold has shown as much as 20 hp over the Shootout. Note that these increases mainly occur in the 7,500 to 8,000 rpm range.

Shootout Pro

For more performance with large cubic inch engines (420+) on fuel, or any size alcohol engine, the shootout pro is the manifold for you. It features a larger plenum and bigger runners than the other Shootout manifolds.

Podium

The Platform

1500-6500
RPM RANGE

The Speedmaster™ Podium Manifolds combine two four-barrel carburetors to achieve the best balance of drivability, great looks, and outstanding performance for muscle car, street rod and marine applications. Featuring a low profile design and a high flow runner design these manifolds will improve performance from 1500-6500 RPM range.

Fusion

Ultra High Flow

3500-7500
RPM RANGE

The unique two piece design is ready to bolt-on or perfect for serious engine builders who hand port or CNC machine the manifolds to suit specific combinations. Designed to work best on engines making up to 800+ hp and provides the highest average torque and horsepower without sacrificing top end performance. Cast with a 4500 Dominator flange it removes the need for spacers or specialised expensive welding and modifications.

Podium Combinations

Truly Versatile

Podium Intake Manifold



Adapter Plate



Supercharger



Adapter Plate



Spacers



Throttle Bodies



Carburetors

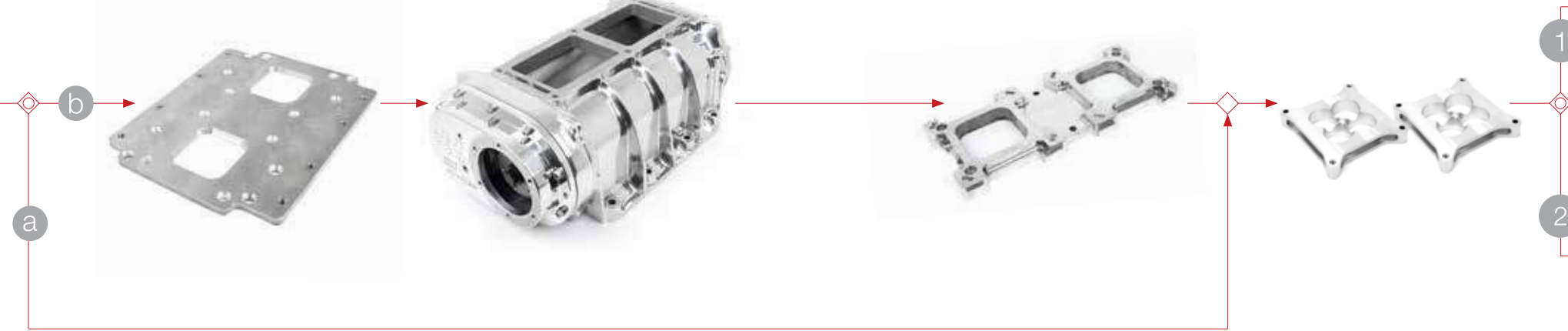

a1



a2



b1



b2

Chevrolet Small Block

5.7L 350

Holeshot



Holeshot +Plus



Qualifier



Eliminator



Shootout

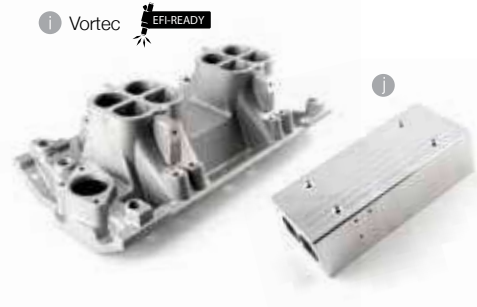

Shootout +Plus



Shootout Pro



Shootout Pro

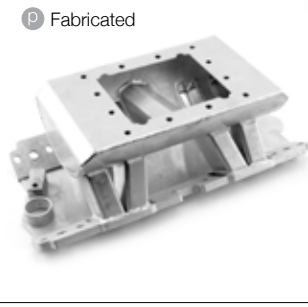

Podium



ITB



Product Line	Ref.	Application	Finish	SKU	
Holeshot	a.	1957-95	Natural	PCE147.1002	
			Ceramic Coated	PCE147.1096	
			Polished	PCE147.1001	
			Chrome	PCE147.1003	
			1957-86 Non Slotted	Natural	PCE147.1097
	b.	Vortec	1957-86	Polished	PCE147.1095
			Chrome	PCE147.1004	
			Natural	PCE147.1006	
			Ceramic Coated	PCE147.1098	
			Polished	PCE147.1005	
c.	1957-95 (Egr)	Polished	PCE147.1007		
		Natural	PCE147.1008		

Product Line	Ref.	Application	Finish	SKU
Holeshot +Plus	d.	1957-95	Polished	PCE147.1009
			Natural	PCE147.1010
			Chrome	PCE147.1013
			Polished	PCE147.1011
			Natural	PCE147.1012
	e.	1957-95 (w/o Kit)	Chrome	PCE147.1014
			Ceramic Coated	PCE147.1099
			Polished	PCE147.1015
			Natural	PCE147.1016
			Chrome	PCE147.1017
Qualifier	e.	1957-95	Ceramic Coated	PCE147.1100
			Polished	PCE147.1018
			Natural	PCE147.1019
			Ceramic Coated	PCE147.1101
			Polished	PCE147.1020
Eliminator	g.	Vortec	Natural	PCE147.1021

Product Line	Ref.	Application	Finish	SKU
Shootout	h.	1957-95	Polished	PCE147.1022
			Natural	PCE147.1023
Plenum	i.	TPI EFI Vortec	Natural	PCE148.1041
			Polished	PCE148.1042
Shootout +Plus	k.	Vortec	Polished	PCE147.1024
			Natural	PCE147.1025
	l.	1957-95	Polished	PCE147.1026
			Natural	PCE147.1027
			Polished	PCE147.1028
Shootout Pro	m.	1957-95	Natural	PCE147.1029
			Polished	PCE148.1001
	n.	1957-95	Natural	PCE148.1002
			Polished	PCE148.1044
	o.	1957-95 - 15 Degree	Natural	PCE148.1045
			Natural	PCE148.1045
			Fabricated	PCE147.1067

Product Line	Ref.	Application	Finish	SKU
Podium	q.	1957-95	Natural	PCE147.1087
6-71 Adapter	r.	1957-95	Polished	PCE149.1003
			Natural	PCE148.1011
ITB	t.	Down-Draft	Natural	PCE148.1009
			Natural	PCE148.1010

Chevrolet Big Block

6.5L **396** · 7.4L **454**

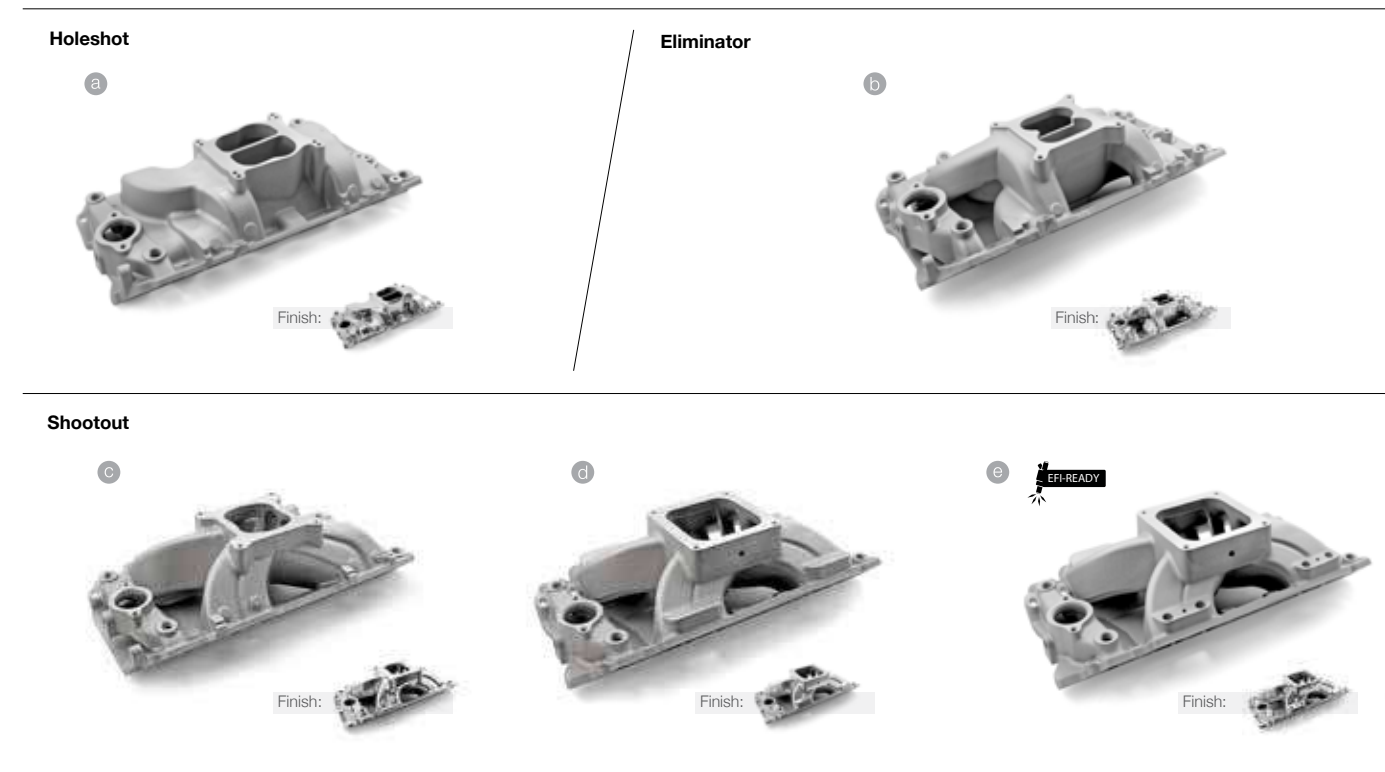

Product Line	Ref.	Application	Finish	SKU
Holeshoot	a	Oval Port	Polished	PCE147.1030
			Natural	PCE147.1031
			Chrome	PCE147.1032
			Ceramic Coated	PCE147.1104
Eliminator	b	Oval Port	Polished	PCE147.1033
			Natural	PCE147.1034
			Polished	PCE147.1035
			Natural	PCE147.1036
Shootout	c	Rectangular Port	Ceramic Coated	PCE147.1102
			Polished	PCE147.1039
			Natural	PCE147.1040
			Polished	PCE147.1037
			Natural	PCE147.1038
Shootout	d	Rectangular Port	Natural	PCE147.1038
			Ceramic Coated	PCE147.1103
			Polished	PCE148.1012
Shootout	e	Rectangular Port - w/ Inj Ports	Natural	PCE148.1013
			Polished	PCE148.1012
ITB	-	Down-Draft Complete	Natural	PCE148.1053

Holden

5.0L **253** · 5.0L **304** · 5.0L **308**

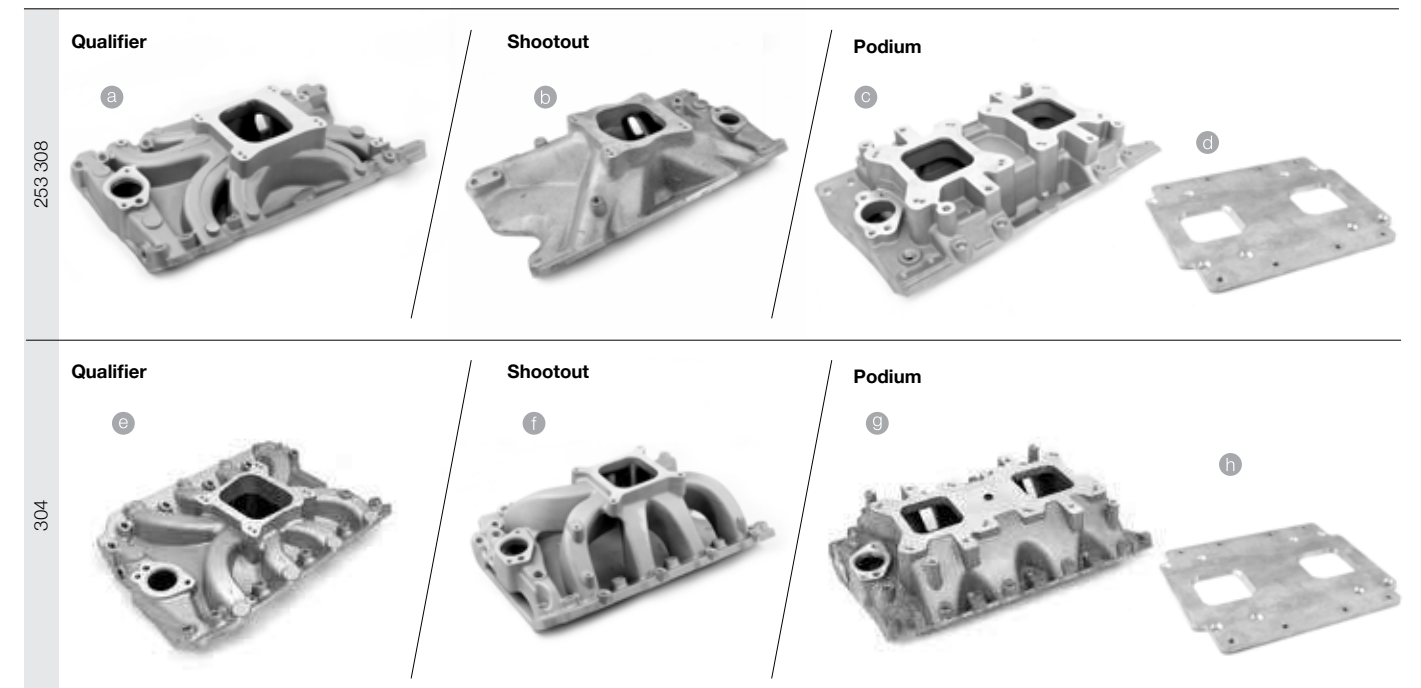

253 308

Product Line	Ref.	Finish	SKU
Qualifier	a	Natural	PCE147.1063
Shootout	b	Natural	PCE147.1064
Podium	c	Natural	PCE147.1084
6-71 Adapter	d	Polished	PCE149.1004

304

Product Line	Ref.	Finish	SKU
Qualifier	e	Natural	PCE147.1065
Shootout	f	Natural	PCE147.1066
Podium	g	Natural	PCE147.1083
6-71 Adapter	h	Polished	PCE149.1009

Chrysler

5.2L **318** · 5.9L **360** · 7.2L **440**



318 360

Product Line	Ref.	Finish	SKU
Eliminator		Polished	PCE147.1055
		Natural	PCE147.1056
Shootout		Natural	PCE147.1086

440

Product Line	Ref.	Finish	SKU
Shootout Pro		Natural	PCE148.1047



5.7L LS1/LS6 • 6.0L LS2 • 6.2L LS3/L99 • 7.0L LS7

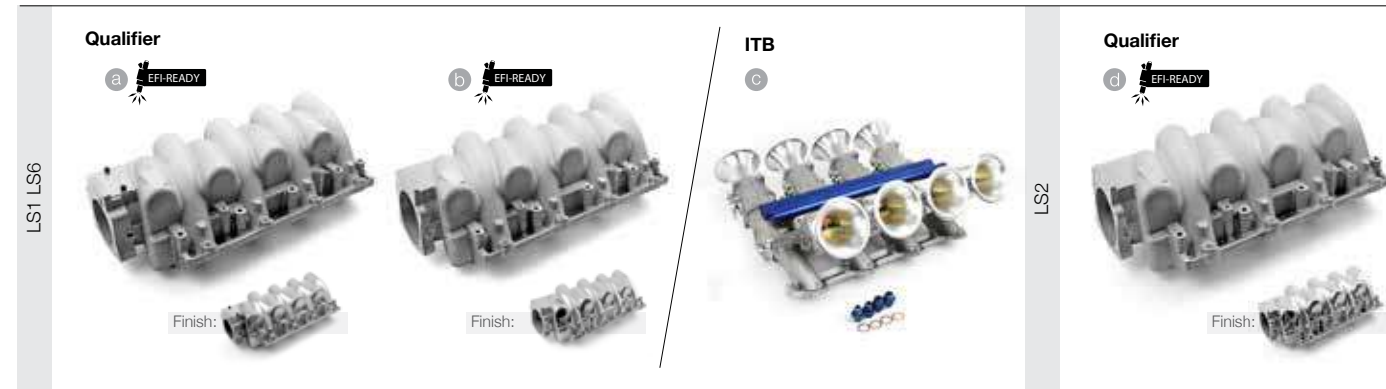

LS1 LS6

Product Line	Ref.	Application	Finish	SKU
Qualifier	a	85mm	Polished	PCE148.1003
			Natural	PCE148.1004
	b	96mm	Polished	PCE148.1007
			Natural	PCE148.1008
ITB	f	Side-Draft Complete	Natural	PCE148.1050

LS2

Product Line	Ref.	Application	Finish	SKU
Qualifier	c	96mm	Polished	PCE148.1005
			Natural	PCE148.1006

LS3

Product Line	Ref.	Application	Finish	SKU
Shootout	d	4500 Flange	Natural	PCE147.1110
ITB	g	Down-Draft Complete	Natural	PCE148.1049
Blower	i	6-71 8-71 Fabricated	Polished	PCE149.1006

LS7

Product Line	Ref.	Application	Finish	SKU
Qualifier	-	-	Natural	PCE148.1051
Shootout	e	4500 Flange	Natural	PCE147.1106
ITB	h	Down-Draft Complete	Natural	PCE148.1043
Blower	j	6-71 8-71 Fabricated	Polished	PCE149.1007

Pontiac

5.3L 326 • 6.6L 400 • 7.5L 455

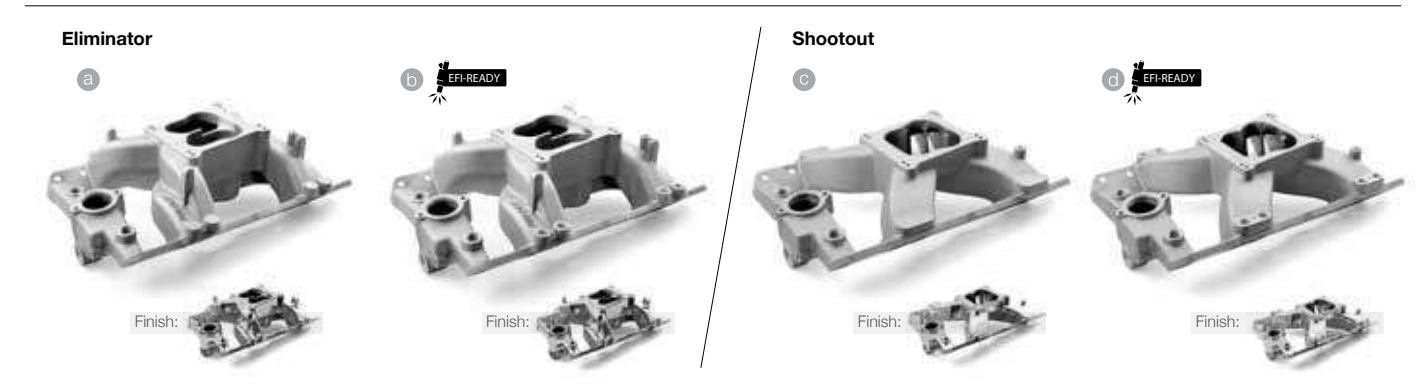

Product Line	Ref.	Application	Finish	SKU
Eliminator	a.	-	Polished	PCE147.1057
			Natural	PCE147.1058
	b.	w/Inj Ports	Polished	PCE148.1035
			Natural	PCE148.1036
Shootout	c.	-	Polished	PCE147.1059
			Natural	PCE147.1060
	d.	w/Inj Ports	Polished	PCE148.1037
			Natural	PCE148.1038

Oldsmobile

6.6L 400 • 7.0L 425 • 7.5L 455

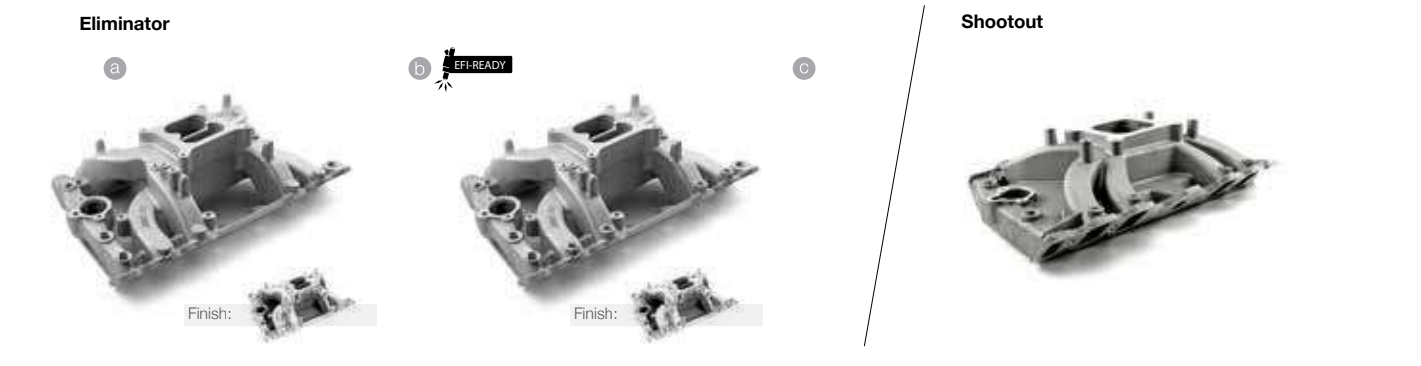

Product Line	Ref.	Application	Finish	SKU
Eliminator	a.	-	Polished	PCE147.1061
			Natural	PCE147.1062
	b.	w/Inj Ports	Polished	PCE148.1039
			Natural	PCE148.1040
Shootout	c.	-	Natural	PCE147.1107

Ford Small Block Windsor

4.7L **289** • 5.0L **302**

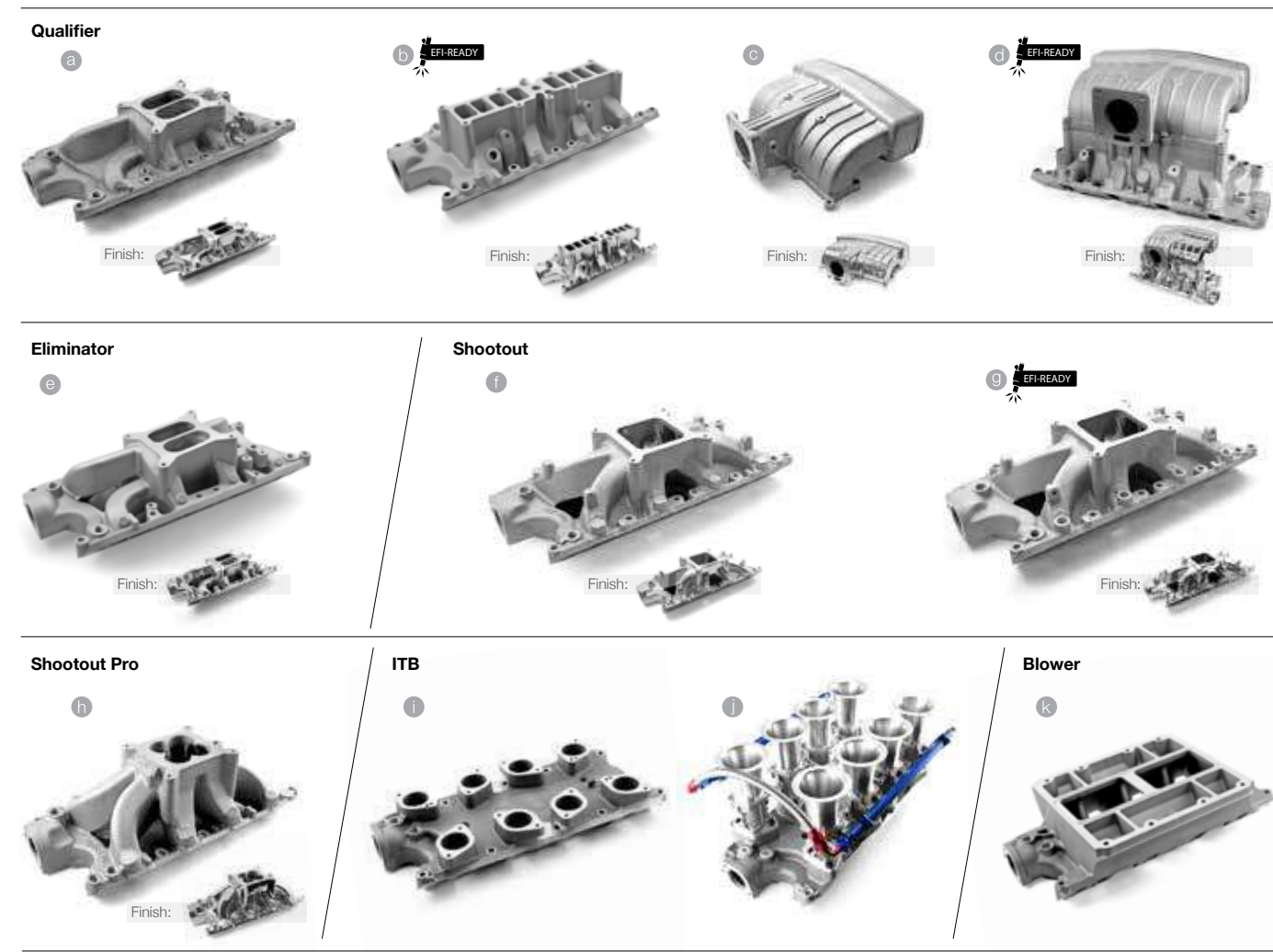

Product Line	Ref.	Application	Finish	SKU
Qualifier	a.	-	Polished	PCE147.1041
			Natural	PCE147.1042
			Chrome	PCE147.1043
	b.	EFI 1986-93	Polished	PCE148.1022
			Natural	PCE148.1023
	c.	Upper Plenum - EFI 1986-93	Polished	PCE148.1024
			Natural	PCE148.1025
	d.	Complete - EFI 1986-93	Polished	PCE148.1014
			Natural	PCE148.1015
Eliminator	e.	-	Polished	PCE147.1047
			Natural	PCE147.1048
Shootout	f.	-	Polished	PCE147.1049
			Natural	PCE147.1050
			g.	w/ Inj Ports
Natural	PCE148.1019			
Shootout Pro	h.	-	Natural	PCE147.1076
			Polished	PCE147.1077
ITB	i.	Down-Draft	Natural	PCE148.1031
			Polished	PCE148.1032
Blower	j.	Down-Draft Complete	Natural	PCE148.1032
			Polished	PCE148.1032
Blower	k.	6-71 8-71	Natural	PCE149.1001
			Polished	PCE149.1001

Ford Small Block Windsor

5.8L **351**

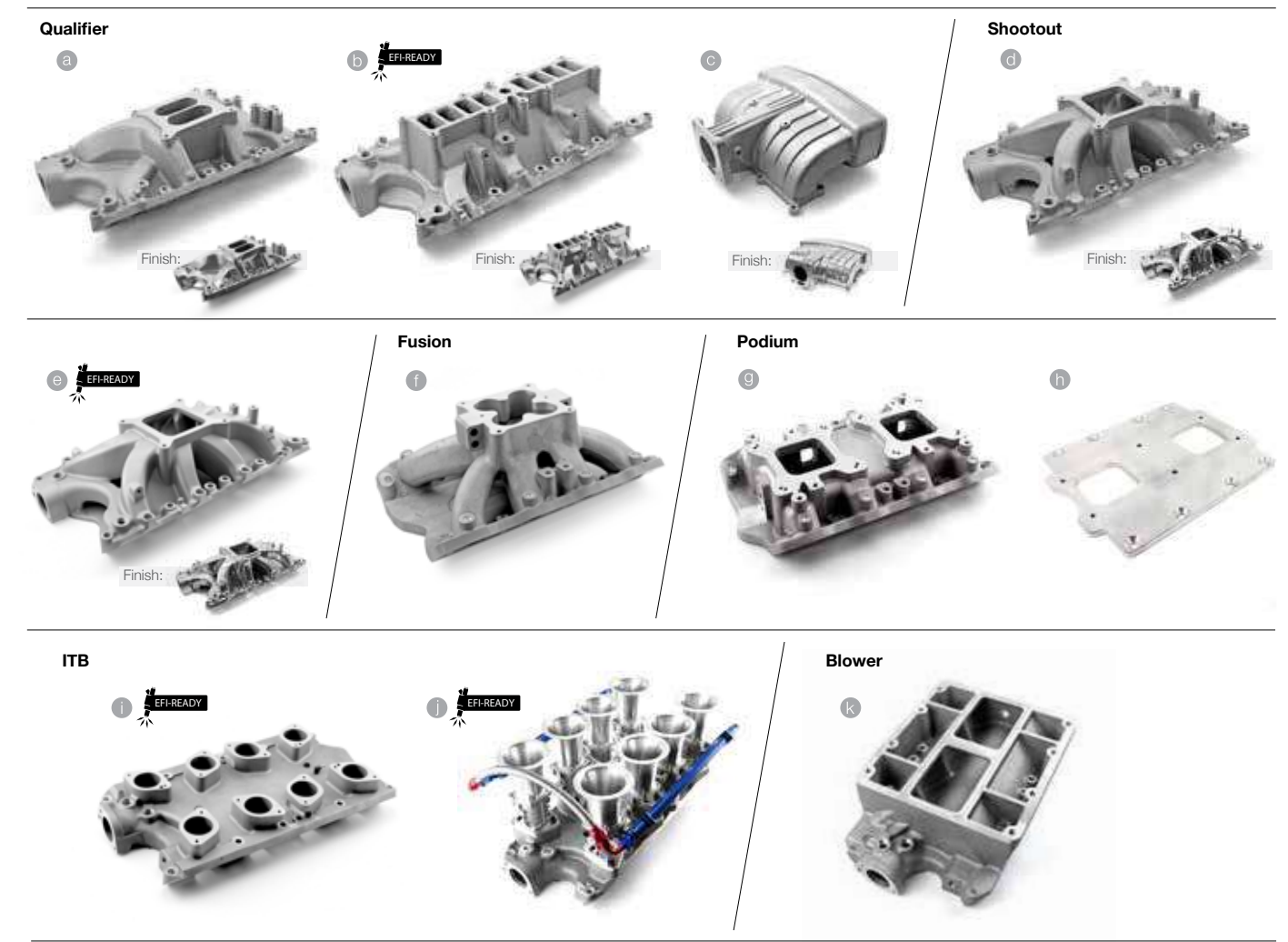

Product Line	Ref.	Application	Finish	SKU	
Qualifier	a.	-	Polished	PCE147.1044	
			Natural	PCE147.1045	
			Chrome	PCE147.1046	
	b.	EFI 1986-93	Polished	PCE148.1026	
			Natural	PCE148.1027	
	c.	Upper Plenum - EFI 1986-93	Polished	PCE148.1024	
			Natural	PCE148.1025	
	Shootout	d.	-	Polished	PCE147.1051
				Natural	PCE147.1052
Fusion	f.	3V (4V w/Tongues)	Polished	PCE148.1016	
			Natural	PCE148.1017	
Podium	g.	3V (4V w/Tongues)	Natural	PCE147.1054	
			Polished	PCE147.1088	
6-71 Adapter	h.	-	Polished	PCE149.1008	
			Natural	PCE149.1008	
ITB	i.	Down-Draft	Natural	PCE148.1033	
			Polished	PCE148.1034	
Blower	j.	Down-Draft Complete	Natural	PCE148.1034	
			Polished	PCE148.1034	
Blower	k.	6-71 8-71	Natural	PCE149.1002	
			Polished	PCE149.1002	

Ford Cleveland

5.8L 351

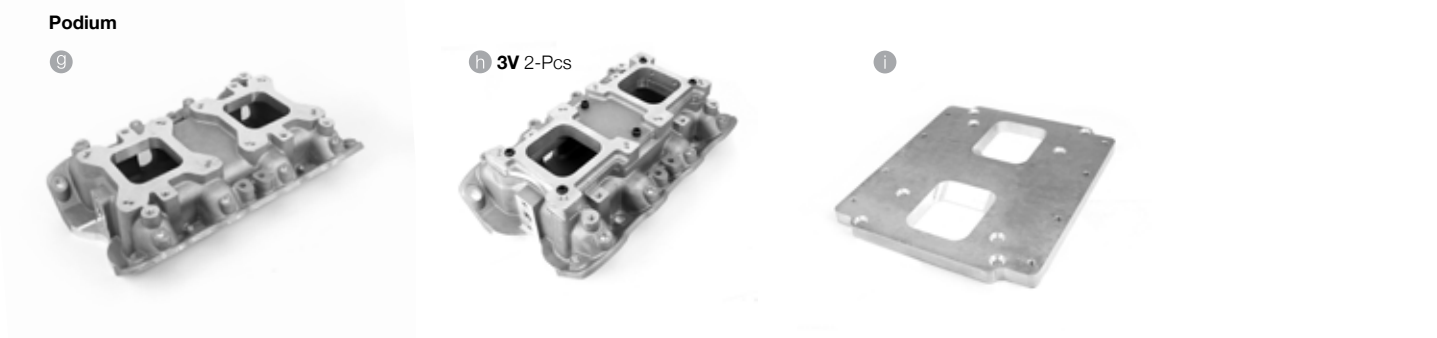
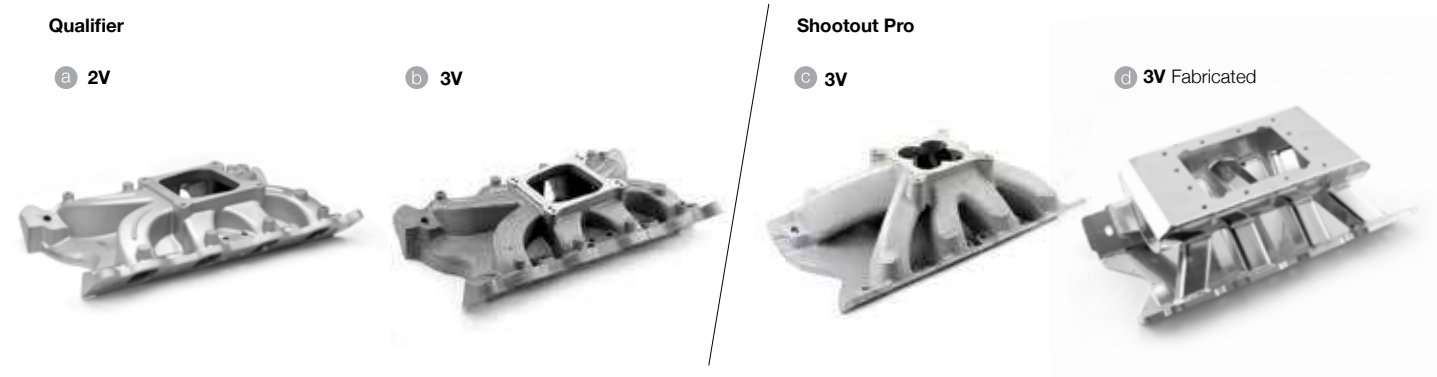

Product Line	Ref.	Application	Finish	SKU
Qualifier	a.	2V	Natural	PCE147.1079
	b.	3V (4V w/Tongues)	Natural	PCE147.1080
Shootout Pro	c.	3V (4V w/Tongues)	Natural	PCE147.1081
	d.	3V (4V w/Tongues)	Fabricated Natural	PCE147.1082
Fusion	e.	3V (4V w/Tongues)	Natural	PCE147.1053
ITB	f.	Down-Draft Complete	Natural	PCE148.1052
Podium	g.	3V (4V w/Tongues)	Natural	PCE147.1089
		2V	Natural	PCE147.1091
	h.	3V (4V w/Tongues)	Natural	PCE147.1091
6-71 Adapter	i.	Podium Manifolds	Polished	PCE149.1005

Ford Big Block

7.0L 429 • 7.5L 460

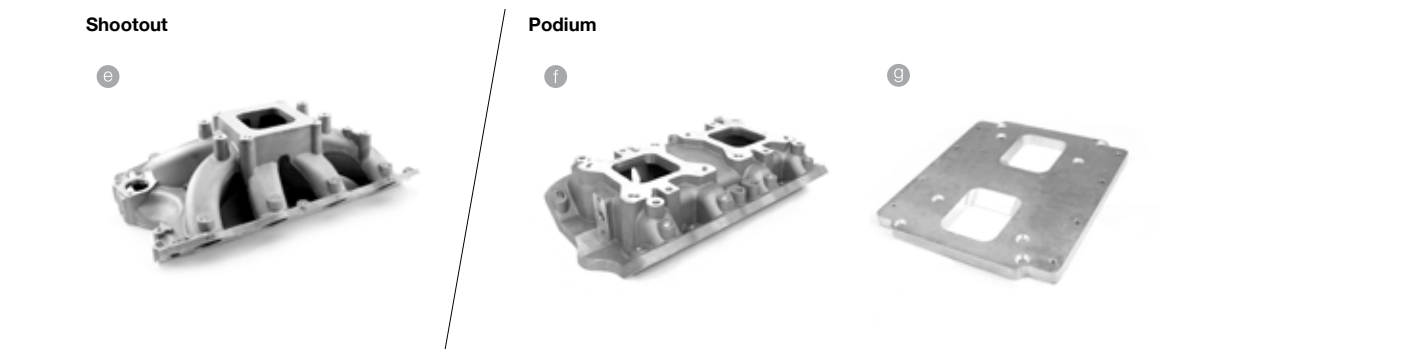

Product Line	Ref.	Application	Finish	SKU
Shootout	e.	4150 Cobra Jet Ports	Natural	PCE148.1046
Podium	f.	-	Natural	PCE147.1105
6-71 Adapter	g.	-	Polished	PCE149.1012

Ford Modular

4.6L SOHC



Product Line	Ref.	Application	Finish	SKU
Qualifier	a.	EFI 1999-04	Polished	PCE148.1020
			Natural	PCE148.1021
	-	Center Plenum 2V	Natural	PCE148.1028
	-	Upper Plenum 2V	Polished	PCE148.1029
	-	Upper Plenum 2V	Natural	PCE148.1030

Carburetors

Impressive Air and Fuel Blending



The goal of a carburetor is to mix just the right amount of fuel with air so that the engine runs properly. If there is not enough fuel mixed with the air, the engine "runs lean" and either will not run or potentially damages the engine. If there is too much fuel mixed with the air, the engine "runs rich" and either will not run (it floods), runs very smoky, runs poorly (bogs down, stalls easily), or at the very least wastes fuel. The carb is in charge of getting the mixture just right. Give such an important job to our Speedmaster™ Carburetors.

Speedmaster™ Carburetor Features:

- Metering blocks with changeable emulsion bleeds and idle feed restrictors.
- Power valve restrictors allow for Infinite tuning and tailoring to any engine.
- Large glass sight windows for quick fuel level adjustments.
- Aluminum base plate for strength and durability.
- Adjustable accelerator pump.
- Stainless Steel throttle plates.
- Changeable Emulsion Jets.
- Calibrated for gasoline.
- Screw In air bleeds.
- Dual fuel inlets.
- Idle Feed Restrictors.
- 4 corner idle.**
- Down leg boosters.**
- Progressive secondaries.**

** Only +750cfm



350 cfm

2-Barrel

Speedmaster™ 350cfm carburetors are perfect for street, strip & track where 2 barrel carbs are required, or for those looking for a high quality carburetor at a low price. They Feature Universal Welded Throttle lever, straight boosters, center hung float bowl, high flow venturi and standard 5 1/8 in. air cleaner flange.

- PCE121.1005 Zinc-Chrome Mechanical Secondary

600 cfm

4-Barrel | Square bore

Speedmaster™ 600cfm 4-barrel carburetors are designed for a variety of configurations for street, strip, and track performance. Developed on dyno runs, racers and street heroes alike, Speedmaster™ has taken their carburetors to the next level and set a standard for performance and reliability that's hard to beat.

- PCE121.1008 Zinc-Chrome Mechanical Secondary
- PCE121.1009 Zinc-Chrome Vacuum Secondary
- PCE121.1015 Full Zinc Mechanical Sec Carburetor

610 cfm

4-Barrel | Square bore

Equipped with all-new Tru-Set needle and seats, which have eliminated the need for external adjustments. This change allows for easier "bolt-on-and-go" performance. The floats have been factory-set for optimum fuel levels at 3 to 6 psi of fuel pressure and should never need adjustment. If you're running over 6 psi of fuel pressure, a fuel regulator is required. These carburetors also include a new, refined appearance on their float bowls, main bodies, and vacuum secondary caps. Along with having upgraded choke caps for smoother engine warm-up and better cold drivability.

- PCE121.1017 Full Silver Mechanical Secondary
- PCE121.1006 Full Silver Vacuum Secondary

750 cfm

4-Barrel | 4150

The Race Bred Outlaw is perhaps the best value for the dollar in the carburetor market today. Taking some development on dyno runs, racers and street heroes alike, Speedmaster™ has taken their carburetors to the next level. Since they're aimed directly at optimizing power and performance for any application, other important modifications include screw-in air bleeds, stainless steel throttle plates, and notched floats. They also have Dominator style fuel bowls to allow fuel line plumbing from either side. Designed for high output street engines and for race engines.

- PCE121.1003 Full Zinc Mechanical Secondary
- PCE121.1012 Full Zinc Vacuum Secondary

830 cfm

4-Barrel | 4150

Dual Inlet

The Race Bred Outlaw is perhaps the best value for the dollar in the carburetor market today. Taking some development on dyno runs, racers and street heroes alike, Speedmaster™ has taken their carburetors to the next level. Since they're aimed directly at optimizing power and performance for any application, other important modifications include screw-in air bleeds, stainless steel throttle plates, and notched floats. They also have Dominator style fuel bowls to allow fuel line plumbing from either side. Designed for high output street engines and for race engines.

- PCE121.1011 Zinc-Chrome Mechanical Secondary

950 cfm

4-Barrel | 4150

Dual Inlet Billet

The Speedmaster™ billet carburetor is the most powerful and responsive carburetor of its size. Every angle of throttle position is adjustable. Every effort to improve performance and simplify carburetor design was made. This carburetor flows 950 CFM at 20" of water. Venturi diameter is 1.585". It's recommended for engines of 550 to 850+ HP. The billet design has improved booster signal by 50%, reducing manifold wetting by surrounding; the fuel being distributed by the booster with a layer of air to keep fuel off of the walls. It has fuel emulsion technology incorporated into the metering blocks: to reduce droplets to previously unattainable size.

- PCE121.1016 Full Billet Mechanical Secondary 3 Circuit
- PCE121.1013 Full Billet Mechanical Secondary 2 Circuit

1050 cfm

4-Barrel | Dominator

Dual Inlet Billet

Speedmaster™ Dominator carburetors feature CNC Machined aluminum main body, which has a lengthened venturi section for greater midrange torque and better airflow. The annular booster venturis are precision die-cast with CNC-machined billet aluminum inserts, providing smoother and more refined air entry, a stronger vacuum signal, less turbulence, and improved fuel emulsion for better combustion. Dominator carburetors use red anodized billet aluminum CNC-machined metering blocks featuring 3-circuit metering (gasoline carburetors), changeable emulsion, idle feed, and intermediate bowl and feed discharge. The aluminum fuel bowl combines high strength with significant weight reduction. They feature dual threaded fuel inlets/outlets and dual sight glass holes to easily set the float levels.

The carburetors feature external linkage with four different links to select the amount of primary throttle opening before the secondaries open: moderate progressive (25 %), medium progressive (40 %), full progressive (50 percent), and 1:1. All features result in improved throttle response and increased consistency are all part of the package. Whether you use a throttle stop or run heads-up this carburetor will help you get to the winner's circle. Hand assembled and engine tested in USA.

- PCE121.1014 Full Billet Mechanical Secondary Dominator

Carburetor Secondaries

A mechanical secondary carburetor uses a solid linkage between the primary barrels and the secondary barrels to open them both at the same time. A vacuum secondary uses a vacuum diaphragm to keep the secondary throttle plates closed as long as the engine has vacuum, meaning at low rpm and under part-throttle conditions. Under wide-open-throttle conditions, vacuum in the manifold drops and the engine gets its full dose of air and fuel.



Vacuum Secondaries

While treated as little more than a fuel economy booster, the vacuum carb does have a few performance advantages over the mechanical secondary. Because it feeds the engine only as much air and fuel as it'll take, the vacuum secondary carb has the ability to self-adjust to some extent to the size of the engine. It's more forgiving in terms of tuning and helps to boost engine torque, fuel economy and engine efficiency by maintaining maximum air velocity through the carburetor venturis.



Mechanical Secondary

If the vacuum secondary carb has one major drawback, it's that it has to respond to the engine's demand for air and fuel before it opens and that takes time. The mechanical secondary's ability to instantly open all air and fuel passages in direct accordance to throttle position means that it can offer instant throttle response without the slight lag associated with vacuum secondaries. In addition, you'll never have to worry that the vacuum secondaries aren't opening all the way.

How to choose one?

For street cars the vacuum secondary carburetor works best on mid weight or heavyweight cars with an automatic transmission. They are more forgiving than a Dual Inlet is because they work by sensing engine load. The mechanical secondary carburetor is best on a lighter car with radical camshaft and a lower gear and manual transmission or on a car that is going to be used for street and strip purposes.

Throttle Bodies

Smooth Air Flow

The key to improving power on any internal combustion engine is maximizing its volumetric efficiency. Speedmaster™ throttle bodies are designed and manufactured to deliver more air for increased performance. The throttle blade is securely staked to the throttle shaft to ensure a secure fit and finish and the throttle shaft rides on sealed ball bearings for smooth, safe operation. Speedmaster™ throttle bodies are available in several sizes to suit your application. Smaller sizes are slightly larger than stock and are a great first step for stock or mildly modified engines, while larger sizes are for more radical engine combinations, and in most cases, require port matching of the manifold for proper fitment.

Carby-Style Entry Level

Speedmaster™ universal Carburetor Style throttle body is ideal for any V8 engine originally equipped with a carburetor and intake manifold with a square-bore 4150 style flange. While the throttle body looks like a carburetor, it is actually a fully contained throttle body.

LS High Flow

Speedmaster™ LS Hi Flow throttle bodies are ready to bolt on. Installation is a simple process for the novice or experienced enthusiast. LS Series throttle bodies were designed to provide smooth and predictable performance from idle to WOT (Wide Open Throttle). Featuring a factory style stamped steel throttle linkage for a precise, consistent fit and with the included throttle cable bracket it provides a low cost manifold alternative by allowing the use of the LS2 Manifold on applications that require a throttle cable. All throttle bodies are machined from billet 6061-T6 aluminum on precision CNC machining centers for consistent quality.

4-Barrel Smooth & Stable

Speedmaster™ 4-Barrel Throttle Bodies are designed to produce smooth, stable air flow at any rpm. The entire throttle body begins as a billet block of 6061-T6 aluminum for superior quality and produced on a state-of-the-art CNC machine. From here it is precisely machined resulting in overall accuracy to within 0.001"! The air inlets are formed with radiused openings to supply a smooth entrance for the air. Brass throttle blades control vibration & reduce thermal expansion. Bearing mounted butterfly shafts for smooth throttle action, Shorter height for better airflow, easier packaging for tight hood clearance and reduced weight Comes complete with billet arms and stops and provision for TPS on unit.

Carby-Style



LS2



4-Barrel



Ref.	Application	Airflow Rate (cfm)	Venturi Quantity	Throttle Body Material	Throttle Body Finish	SKU
a.	Universal 4150	750 cfm	4	Cast aluminum	Chrome	PCE138.1007
b.	GM LS2 90.00mm	-	1	Billet aluminum	Black anodized	PCE138.1004
c.	GM LS2 92.00mm	-	1	Billet aluminum	Clear anodized	PCE138.1005
d.	GM LS2 102.00mm	-	1	Billet aluminum	Clear anodized	PCE138.1006
e.	Universal 4150	1000 cfm	4	Billet aluminum	Natural	PCE138.1001
f.	Universal 4150	1200 cfm	4	Billet aluminum	Natural	PCE138.1002
g.	Universal 4500	2200 cfm	4	Billet aluminum	Natural	PCE138.1003

Carburetor Spacers

Built to Endure the Tough Conditions

Individually milled from super durable 6061 T6 aluminum billets, these spacers can handle anything your vehicle can dish out. They're so tough, they're guaranteed for life. The precise design of these Speedmaster™ carburetor spacers provides a smooth transition of fuel from the carburetor to the intake manifold, to increase flow for more performance. They also help to insulate the carburetor from engine heat and provide clearance for linkages.

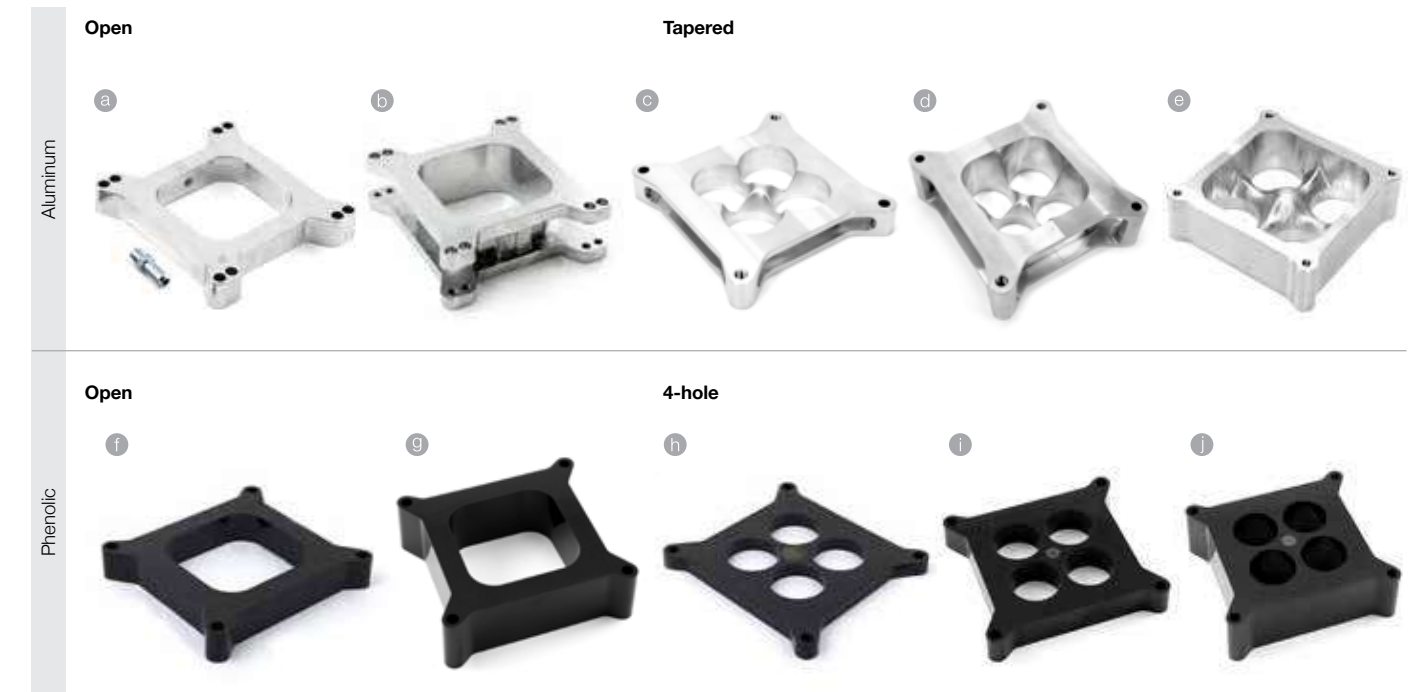

Carburetor Adapters

Speedmaster™ carburetor adapters are designed to allow you to bolt a different bolt pattern carburetor to your existing intake manifold, to save you the expense of buying a different manifold or carburetor. Made from high-quality cast aluminum, these adapters provide a smooth transition from carb to intake for trouble-free operation.



a.	PCE120.1002	1" Aluminum Open w/Vacuum Tube	f.	PCE120.1005	1" Phenolic Open	k.	PCE110.1001	1" Aluminum Holley to Quadrajet Q-Jet and Spreadbore
b.	PCE120.1001	2" Aluminum Open	g.	PCE120.1006	2" Phenolic Open			
c.	PCE120.1008	1" CNC Aluminum 4150 Tapered	h.	PCE120.1007	1/2" Phenolic 4-hole 1" Phenolic 4-hole			
d.	PCE120.1009	2" CNC Aluminum 4150 Tapered	i.	PCE120.1003	1" Phenolic 4-hole			
e.	PCE120.1010	2" CNC Aluminum 4500 Tapered	j.	PCE120.1004	2" Phenolic 4-hole			

Carburetor Accessories

Carburetor Base Plates

Speedmaster™ carburetor base plates are made with the highest quality products to provide top performance. Can be combined with our other Speedmaster™ carb parts or with high performance carb parts from other manufacturers. Compatible with Holley and Proform carburetor parts. Designed for absolute performance.

Cast



Billet



Ref.	Type	Carburetor Base Plate Material	SKU
a.	350 cfm 2 Barrel	Cast aluminum	PCE111.1004
b.	850 cfm Dual Inlet	Cast aluminum	PCE111.1001
c.	750 cfm Mechanical Secondary	Cast aluminum	PCE111.1002
d.	850 cfm Dual Inlet	Billet aluminum	PCE111.1005
e.	850 cfm Dual Pattern	Billet aluminum	PCE111.1006

Carburetor Metering Blocks

Speedmaster™ fully adjustable metering blocks allow you to stay in complete control of your carburetors fuel delivery. Improved throttle response over stock, fully tunable for street and strip applications. Retains vacuum passage for distributor vacuum advance. Calibration upgrade without sacrificing street vacuum provisions. Direct Holley replacement, fits all 4150 and 4160 carbs.

Cast

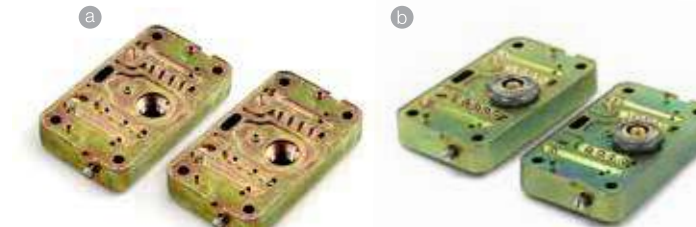

Billet



Ref.	Type	Metering Block Material	Metering Block Finish	SKU
a.	2 Barrel	Cast aluminum	Gold iridited	PCE118.1002
b.	4 Barrel Adjustable	Cast aluminum	Gold iridited	PCE118.1001
c.	4 Barrel Adjustable	Billet aluminum	Red anodized	PCE118.1003
d.	4 Barrel Adjustable 3-Circuit	Billet aluminum	Red anodized	PCE118.1004

Carburetor Main Bodies

Designed for absolute flow and fuel delivery, Speedmaster™ center bodies will help you leave the competition in the dust. Gain 25-35hp with this direct replacement, 100% new high performance carb main bodies. Easy swap in, swap out installation utilizing existing metering blocks, fuel bowls and base plates. Flows 850 cfm, adjustable screw in air bleeds, down leg boosters. Get maximum air with no air horn choke tower, or choke control in the way.

Cast



Billet



Ref.	Type	Main Body Material	Main Body Finish	SKU
a.	2 Barrel	Cast Aluminum	Dichromate	PCE116.1004
b.	4 Barrel Air Horn Choke Mech Secondary	Cast Aluminum	Dichromate	PCE116.1003
c.	4 Barrel Dual Inlet	Cast Aluminum	Dichromate	PCE116.1001
d.	4 Barrel Dual Inlet 4150	Billet Aluminum	Red anodized	PCE116.1005
e.	4 Barrel Dominator 4500	Billet Aluminum	Clear anodized	PCE116.1002

Carburetor Fuel Bowls

Speedmaster™ fuel bowls come with sight glass windows for easy visual float adjustments. Lightweight, center hung design make it completely compatible with Speedmaster™, Holley, Proform and Quick Fuel carburetors. Sold Individually.



Ref.	Carburetor Fuel Bowl Finish	Accelerator Pump Provision	Fuel Bowl Float Style	SKU
a.	Chrome	No	Center hung	PCE115.1003
b.	Chrome	Yes	Center hung	PCE115.1001
c.	Chrome	Yes	Center hung	PCE115.1002

Carburetor Accessories

Carburetor Components

All Speedmaster™ Carburetors components are individually tested. These carburetors components are ready to bolt on and go.



Carburetor Stud Kit

Speedmaster™ carburetor stud kits include stainless studs, stainless nuts, and stainless lock washers. You can depend on Speedmaster™ for the quality fuel system hardware that you need.



Carburetor Dust Covers

Keep dirt and foreign objects out of your carburetor during storage, transportation, and down time at the racetrack with one of these carburetor caps from Speedmaster™. They fit carburetors with 5 1/8 in. necks and are available in two versions--a durable plastic model and a thick aluminum model that won't bend after multiple uses.



- | | | |
|--|--|---|
| a. PCE119.1001 Needle & Seat Screw Kit | h. PCE456.1001 Chrome Fuel Bowl Bolt 66mm (Allen Head) | i. PCE113.1007 Stud Set Kit - 5/16" x 20 x 0.825" |
| b. PCE114.1001 Center Hung Fuel Float | i. PCE117.1002 Blue Reusable Fiber Gasket | PCE113.1005 5/16" x 20 x 0.900" |
| c. PCE123.1001 Manual Choke (Mech Second w/ Air Horn) | j. PCE437.1001 3.5" Carburetor Power Valve | PCE113.1006 5/16" x 20 x 1.350" |
| d. PCE123.1002 Manual Choke (Dual Inlet Body) | k. PCE122.1001 Choke Cable Kit - 6 Foot Long | PCE113.1001 5/16" x 20 x 1.375" |
| e. PCE109.1001 30cc Accelerator Pump Cover Gold Iridited | | PCE113.1009 5/16" x 20 x 1.825" |
| f. PCE109.1003 30cc Accelerator Pump Cover Polished | | PCE113.1002 5/16" x 20 x 2.000" |
| g. PCE109.1002 50cc Accelerator Pump Cover Polished | | PCE113.1010 5/16" x 20 x 2.825" |
| | | PCE113.1003 5/16" x 20 x 3.000" |
| | | PCE113.1011 5/16" x 20 x 3.825" |
| | | m. PCE112.1002 Aluminum (5 1/8" Neck) |
| | | PCE112.1001 Plastic (5 1/8" Neck) |

Throttle Cable Brackets

Speedmaster™ brackets provide for throttle cable and throttle return spring installation. They are just what you need to install your throttle cable the right way. Throttle linkage kits make your carb installation look clean and professional, other kits on the market, have 3 separate items needed to complete the install, however this kit comes complete with the return spring assembly and brackets, also the passing gear bracket.



Throttle Cables

Speedmaster™ universal throttle cable kits contain all of the necessary hardware for a complete installation onto your carburetor. They feature a long cable, that can be cut to length to fit your specific application. The cables are designed with a specially extruded liner for the extended life of the cable and are not to be confused with ordinary braided brake hose. The cables are equipped with polished aluminum fittings and ferrules to eliminate fraying.



Carburetor Linkage Kits

Speedmaster™ sideways-mounted kits are designed for tunnel ram intake manifolds and even 6-71, 8-71 supercharger applications. These kits are competition-style sets using spherical-type rod ends for precise adjustment, and are designed for long and reliable service. They save you the hassle of trying to put together a linkage from scratch.



- | | |
|--|--|
| a. PCE124.1007 Black w/ Return Springs and Mount | c. PCE125.1001 36" Braided Stainless Steel |
| PCE124.1003 Chrome | PCE125.1002 24" |
| PCE124.1004 Red | |
| PCE124.1005 Red/Blue | |
| PCE124.1006 Blue | |
| PCE124.1008 Polished | |
| b. PCE124.1014 Black Billet w/Return Springs | d. PCE476.1001 Dual Side Mount Carburetor Linkage Kit for Blower and Tunnel Ram Applications |
| PCE124.1013 Blue | |
| PCE124.1015 Red | |
| PCE124.1016 Chrome | |

Carburetor Feed Lines

Speedmaster™ dual feed fuel lines are a great addition to any fuel system. The pre-assembled fuel lines clean up your engine compartment and properly deliver fuel to your carburetor.



Quick Tip

Choose the Right Outlet Size



9/16-24 in.



Suits
Speedmaster™
Barry Grant
Demon





7/8-20 in.

Suits
Holley

9/16-24 in.

7/8-20 in.

















These Speedmaster™ universal fuel logs are CNC-machined from billet aluminum and are adjustable to fit a full range of carburetor applications with different styles and configurations of fuel bowls. Speedmaster™ fuel logs come complete with 2 sets of stanchions (9/16-24 in. & 7/8-20 in.) to attach them to the carburetor (Holley, Barry Grant, Demon or Speedmaster™).



- a. PCE341.1004 9/16-24 in. Aluminum log with Regulator
- b. PCE341.1007 9/16-24 in. Aluminum log
- c. PCE341.1009 9/16-24 in. Braided flex line
- d. PCE341.1005 7/8-20 in. Aluminum log with Regulator
- e. PCE341.1006 7/8-20 in. Aluminum log
- f. PCE341.1008 7/8-20 in. Braided flex line
- g. PCE341.1018 9/16-24 in. & 7/8-20 in. Adjustable Aluminum log

Fuel Rails

Our Billet Aluminum lightweight Speedmaster™ fuel rail kits fit like stock, but deliver the increased fuel volume that you need for maximum performance. The kits may include fittings with O-rings for a superior seal, mounting brackets, and stainless steel hardware.

Chevrolet SBC 350	 		Holden 304		
Ford SBF 289 302 351	 		Ford 4.6L		
GM LS1 LS6	 		GM LS2		
GM LS3		Pontiac 326 350 389 400 421 428 455	 	Oldsmobile 400 425 455	

- a. PCE137.1002 Chevy SBC 350 Kit Red
- b. PCE137.1003 Chevy SBC 350 Kit Black
- c. PCE137.1004 Chevy BBC 454 Kit
- d. PCE137.1007 Holden 304 Kit
- e. PCE137.1005 Ford SB 289 302 351 Kit
- f. PCE137.1009 Ford SB 289 302 351 Kit OEM Angled EFI
- g. PCE137.1006 Ford 4.6L EFI 2 Valve 1996-98 (No Reg) Kit
- h. PCE137.1010 Ford 4.6L EFI 2 Valve 1996-98 Kit
- i. PCE137.1001 GM LS1 LS6 Kit Red
- j. PCE137.1016 GM LS1 Black
- k. PCE137.1011 GM LS2 2005-07 Kit
- l. PCE137.1017 GM LS2 Black
- m. PCE137.1018 GM LS3 Black
- n. PCE137.1012 Pontiac Dual Plane Kit
- o. PCE137.1013 Pontiac Single Plane Kit
- p. PCE137.1014 Oldsmobile 400 425 455 Kit

Air Cleaners

Mix & Match

Keep your car running cleaner and longer with one of our many air cleaners. Our air cleaners come in every shape, size or base style you need to complete your job, as well as various finishes. You'll find compatible air filter assemblies to fit both single- and dual-barrel carburetors. Employ a little preventative health care for your car's respiratory system and reap the benefits for many miles to come!



Mix & Match

Speedmaster™ offers a wide range of our popular 14" air cleaners, get the combination you looking for by selecting a top, an element height and a bottom.



Most Popular Combinations

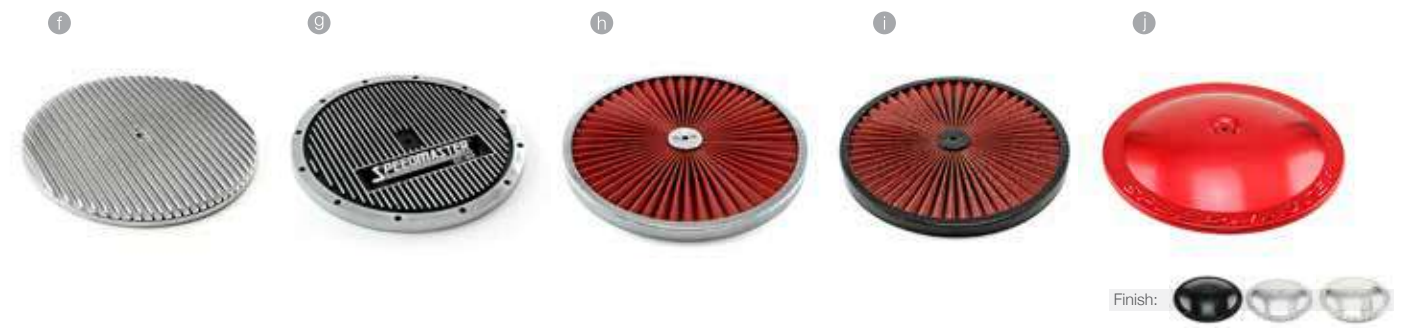

More Sizes

Tops



Bottoms



Filter Elements



- | | | |
|--|---|---|
| a. PCE104.1001 Velocity Stack | h. PCE104.1008 15" x 2" Plain Red Paper | n. PCE104.1009 12" x 2" Flamed |
| b. PCE104.1002 4" x 2 7/8" Deep Dish Style | PCE104.1019 | o. PCE104.1011 12" x 2" Classic Center Finned |
| c. PCE104.1004 4" x 2 7/8" Louvered Style | i. PCE104.1010 15" x 2" Flamed | p. PCE104.1013 12" x 2" Classic Finned |
| d. PCE104.1003 12" x 8" Superflow Triangular | j. PCE104.1012 15" x 2" Classic Center Finned | q. PCE104.1016 14" Classic Center Finned |
| e. PCE104.1082 11 1/2" x 8 1/2" Superflow Triangular | k. PCE104.1014 15" x 2" Classic Finned | r. PCE104.1017 14" Classic Finned |
| f. PCE104.1083 Special Edition Downdraft Look | l. PCE104.1005 12" x 2" Ball Milled | s. PCE104.1015 14" Flamed |
| g. PCE104.1006 15" x 2" Ball Milled | m. PCE104.1007 12" x 2" Plain Red Paper | |
| | PCE104.1018 | |

- | | |
|--|--|
| aa. PCE103.1003 10" Chrome Muscle Car Style Top | ag. PCE101.1003 10" Chrome Raised Base |
| ab. PCE103.1005 15" (15.375") Chrome Top | ah. PCE107.1006 12" x 2" Oval Paper Gauze Element Only |
| ac. PCE103.1006 15" (15.375") Chrome Dual Wing Nut Top | ai. PCE107.1007 15" x 2" Oval Paper Gauze Element Only |
| ad. PCE103.1007 12" Aluminum Oval Ball Milled Top | aj. PCE107.1017 Chevy LS1 LS2 OTR Filter Only |
| ae. PCE103.1008 12" Aluminum Oval Plain Top | ak. PCE107.1018 Velocity Stack Dome Air Filter Drop in Screens |
| af. PCE103.1009 15" Aluminum Oval Plain Top | |

Air Cleaner Assemblies

Dress Up Your Engine

Increasing the flow of air through your engine generally increases performance. Step up to a high performance air cleaner and filter from Speedmaster™. They look great and help to increase horsepower.



15" x 2" Oval



12" x 2" Oval



14" Round



- | | | |
|--|---|---|
| a. PCE104.1001 Velocity Stack | h. PCE104.1008 15" x 2" Plain Red Paper | n. PCE104.1009 12" x 2" Flamed |
| b. PCE104.1002 4" x 2 7/8" Deep Dish Style | i. PCE104.1010 15" x 2" Flamed | o. PCE104.1011 12" x 2" Classic Center Finned |
| c. PCE104.1004 4" x 2 7/8" Louvered Style | j. PCE104.1012 15" x 2" Classic Center Finned | p. PCE104.1013 12" x 2" Classic Finned |
| d. PCE104.1003 12" x 8" Superflow Triangular | k. PCE104.1014 15" x 2" Classic Finned | q. PCE104.1016 14" Classic Center Finned |
| e. PCE104.1082 11 1/2" x 8 1/2" Superflow Triangular | l. PCE104.1005 12" x 2" Ball Milled | r. PCE104.1017 14" Classic Finned |
| f. PCE104.1083 Special Edition Downdraft Look | m. PCE104.1007 12" x 2" Plain Red Paper | s. PCE104.1015 14" Flamed |
| g. PCE104.1006 15" x 2" Ball Milled | | |

Air Cleaner Accessories

Air Cleaner Studs

These Speedmaster™ air cleaner studs are designed to securely mount your air cleaner in position. They are available in standard or offset designs to fit your specific application. The studs are made of high-quality steel and are zinc coated for maximum life.



Air Cleaner Wingnuts

Speedmaster™ air cleaner wing nuts are just what you need to top-off that new air cleaner assembly. They are made to fit any steel or aluminum air cleaner assemblies.



Air Cleaner Adapters

Speedmaster™ air cleaner adapters will adapt your carburetor to a standard-size air cleaner base. They're made from a durable, lightweight, high-impact material that's heat-resistant, too. Make air cleaner fitment a breeze with one of these Speedmaster™ air cleaner adapters.



Air Flow Enhancers

Speedmaster™ protective shrouds let air in, but keep dirt and large debris out of your filter. They extend the life of your air filter element



- | | |
|---|---|
| a. PCE102.1001 4.000 in. Stud 1/4"-20 w/Nut & 1/4"-20 to 5/16"-18 Adapter | h. PCE409.1001 Adapter 5 1/8" to 2 5/8" |
| b. PCE102.1002 4.000 in. Stud 1/4"-20 w/Nut | i. PCE409.1002 Adapter 5 1/8" to 3 1/16" |
| c. PCE102.1003 4.000 in. Stud 1/4"-20 For Offset Air Filter | j. PCE411.1001 Element Shroud Suits: 14" x 3" Element |
| d. PCE102.1004 5.000 in. Bolt | |
| e. PCE105.1001 Nut 5/16-18 Small Black and Chrome | |
| f. PCE105.1002 Nut 5/16-18 Large Black and Chrome | |
| g. PCE105.1004 Nut 1/4-20 Chrome Tri-Bar Style | |

Carburetor Scoops

Increasing the flow of air through your engine generally increases performance. Step up to a high performance air cleaner and filter from Speedmaster™. They look great and help to increase horsepower.



OTR Air Intake Kits +Horsepower



- | | |
|---|---|
| a. PCE106.1006 Polished Aluminum Single & Dual Shot Gun Smooth | g. PCE429.1002 Holden Commodore VT VX VY VZ 5.7L Aluminum Cold Air Intake |
| b. PCE106.1005 Polished Aluminum Single & Dual Shot Gun Finned | h. PCE429.1003 Holden VT VX VY VZ VE LS1 LS2 LS3 Mafless Cold Air Intake |
| c. PCE106.1003 Polished Aluminum Single Hilborn Style | i. PCE429.1001 Chevy LS1 LS2 VT S2 - VZ Cold Air Intake |
| d. PCE106.1002 Polished Aluminum Dual Hilborn Style | |
| e. PCE106.1004 Polished Aluminum Single & Dual Bug Catcher Finned | |
| f. PCE106.1007 Gt Shaker Air Cleaner Assembly | |

Nitrous Oxide

Nitrous Burst Panel Spacers

Speedmaster™ Nitrous burst panel spacers provide the benefits of an open carburetor spacer, but also incorporates replaceable burst panels that will vent pressure between 75-90 psi. for backfire protection with direct port & plate type nitrous systems.

These light weight spacers are precision machined from billet aluminum with a military spec hard coat for durability and corrosion resistance. Can be used with existing nitrous plate systems and burst panels are easily replaced within minutes so you can make the next round.



Nitrous Oxide Plates

Speedmaster™ perimeter plates employ multiple injection points to ensure that a perfectly atomized, cylinder-to-cylinder balanced blend of fuel and nitrous reaches your engine. The technology eliminates nitrous delivery imbalance, the major drawback with spray-bar type nitrous systems. The plates are manufactured from aluminum and are anodized for protection.



Nitrous Oxide Bottle Brackets

Speedmaster™ nitrous oxide bottle brackets are designed to mount your nitrous oxide bottle at the optimal usage angle for the best performance and consistency. They are manufactured from billet aluminum and have a bright machined finish. Suitable with 10-pound nitrous bottle, these lightweight billet aluminum (14.5mm thick) brackets bolt down quickly and simply with the supplied wing nuts. The bracket is lined with rubber to ensure the bottle does not move and is secure. Suits Bottle size 7 in. Diameter. Mounting rails are included in this package



- | | |
|---|--|
| a. PCE474.1001 4150 to 4500 CNC Aluminum | c. PCE150.1001 Billet Aluminum Single Bottle Holder |
| b. PCE151.1005 0.500 Billet Square Bore Black | d. PCE150.1002 Billet Aluminum Dual/Double Bottle Holder |
| PCE151.1002 Red | e. PCE151.1001 4 Barrel 250Hp Installation/Replacement Kit |
| PCE151.1003 Yellow | |
| PCE151.1004 Blue | |
| PCE151.1006 Polished | |

Nitrous Oxide Installation Kit

Speedmaster™ nitrous kit comes with everything shown. All you do is hook up your bottle and your solenoids and you're ready for the track. Designed with 40 delivery holes which makes it the best performing single stage plate system on the market. The kit includes mounting brackets for tank, steel braided lines, carb base plate, carb gaskets, mounting hardware and stainless steel jets.



Fuel Cells

Superior Strength in a Lightweight Package

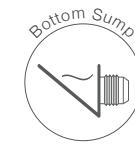
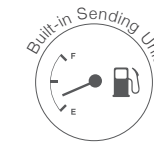

Made from 5051 aircraft aluminum alloy, Speedmaster™ aluminum fuel cells offer superior strength in a lightweight package. The cells have foam in the base to prevent fuel aeration, and have TIG-welded seams. Other features include a flush mount, aircraft-style cap and -10 AN pickup, vent, and return line fittings. Plus, all our models include a 0-90 ohm GM sending unit. Not to be used with methanol.

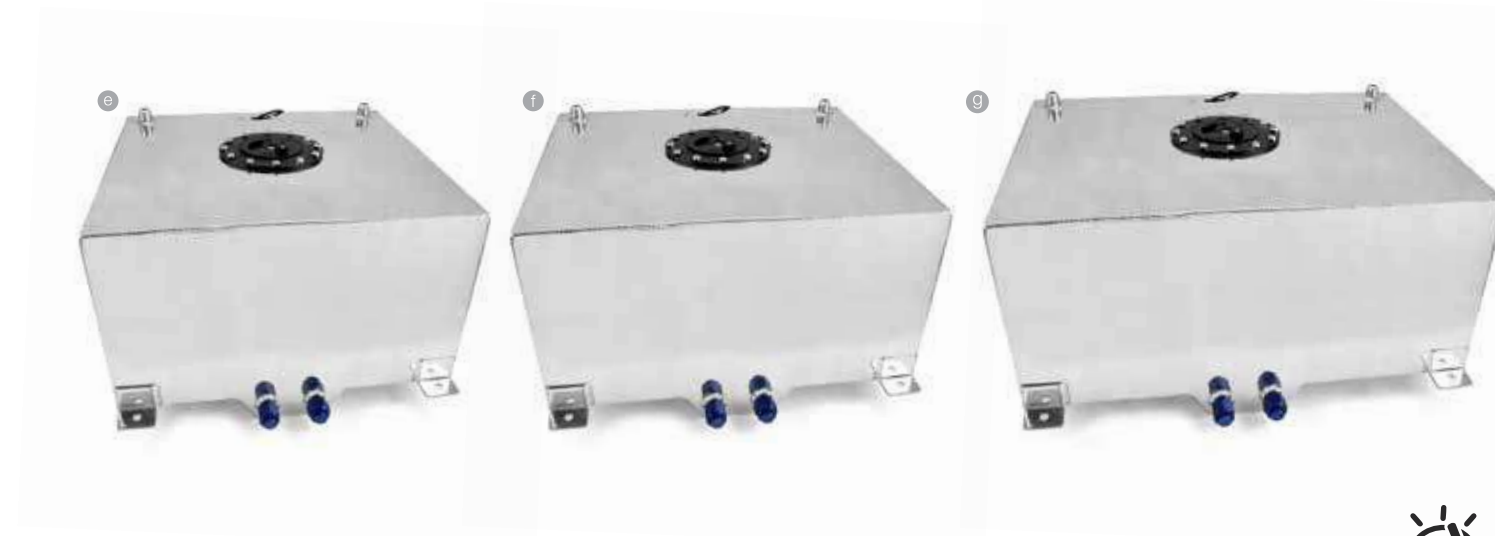

Black Edition

Ref.	Capacity	Fuel Cell Finish	Foam	Length (in)	Width (in)	Height (in)	Outlet Fitting Quantity	Outlet Fitting Size	Vent Fitting Size	Return Fitting Size	Sump	SKU
a.	2.5 gallons (9.4 litre)	Polished	Yes	8.500 in.	8.500 in.	10.000 in.	Two	-10 AN	-10 AN	-10 AN	Yes	PCE130.1001
b.	5 gallons (19 litre)	Polished Black	Yes	12.000 in.	12.000 in.	8.500 in.	Two	-10 AN	-10 AN	-10 AN	Yes	PCE130.1002 PCE130.1008
c.	8 gallons (38 litre)	Polished	Yes	20.000 in.	12.000 in.	9.000 in.	Two	-10 AN	-10 AN	-10 AN	Yes	PCE130.1006
d.	10 gallons (38 litre)	Polished Black	Yes	17.000 in.	17.000 in.	9.000 in.	Two	-10 AN	-10 AN	-10 AN	Yes	PCE130.1003 PCE130.1009
e.	13 gallons (50 litre)	Polished	Yes	20.000 in.	17.000 in.	9.000 in.	Two	-10 AN	-10 AN	-10 AN	Yes	PCE130.1007
f.	15 gallons (57 litre)	Polished Black	Yes	18.000 in.	20.000 in.	9.000 in.	Two	-10 AN	-10 AN	-10 AN	Yes	PCE130.1004 PCE130.1010
g.	20 gallons (76 litre)	Polished Black	Yes	24.000 in.	20.000 in.	10.000 in.	Two	-10 AN	-10 AN	-10 AN	Yes	PCE130.1005 PCE130.1011

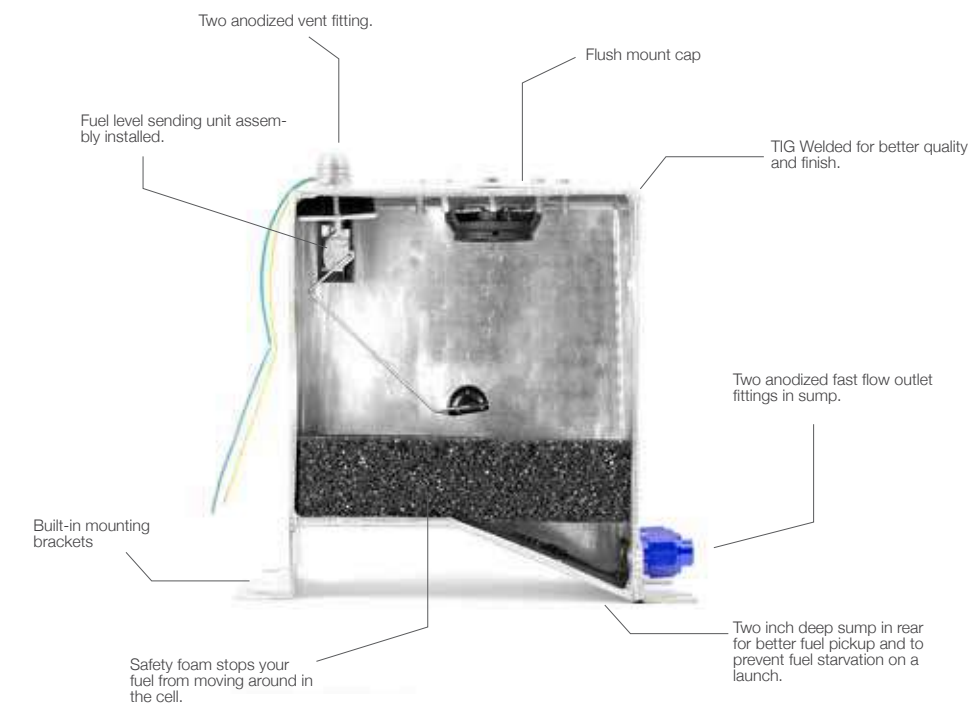

Quick Tip

Safety Foam Information

Under no circumstances should you remove the safety foam from your fuel cell, it serves the following important functions:

Explosion Prevention

Safety foam virtually eliminates the possibility of an explosion in a properly installed fuel cell.

Surge Reduction

Safety foam eliminates sudden fuel movement when the vehicle quickly changes direction. This also helps prevent the fuel cell from rupturing if it receives a sudden impact. In a cell without safety foam, the sudden, violent movement of fuel can deform the cell from the inside out, often causing a massive rupture.

Atomization Prevention

If a fuel cell ruptures violently, a fine, atomized mist of fuel is ejected into the air, creating an explosion hazard. Safety foam minimizes this effect by resisting the rapid dispersment of fuel into the air during an impact.

Fuel Cells Accessories

Caps

Perfect for replacing missing or damaged mounting caps. Speedmaster™ caps will get your project back on the road.



Filler Valves

Designed for those who need to fuel their vehicles as fast as possible. The valves simply replace the flush or D-ring style 12-bolt mounting caps.



Sending Units

Constructed from high-quality materials for reliability, Speedmaster™ fuel level senders fit several types of gauges, including most aftermarket and OEM gauges.



Roll/Tip Over Valves

Speedmaster™ fuel cell tip valves close if your race car rolls, to help prevent fuel leakage and a possible fire. They feature the unique check ball inside to stop the fuel flow during a roll over.



AN Weld-In Bungs

Whether it's a fuel cell, catch can, or oil tank, we offer these top-quality 6061 aluminum weld-in bungs in multiple sizes to fit your fabricating needs. They feature a welding lip to prevent the threads from warping during the welding process.



AN Hose Stainless Steel Braided

Speedmaster™ racing hose is compatible with petroleum and synthetic lubricants, hydrocarbon fuels and liquid engine coolants, it operates at higher temperatures for longer periods. Light and flexible, it is easy to work with and its stainless steel cover will ensure long-lasting durability. Synthetic rubber inner tube that is resistant to oxidation, the effects of ozone and other various agents present in the air. Changes in physical properties due to shelf aging are nonexistent. Not to be used with methanol.

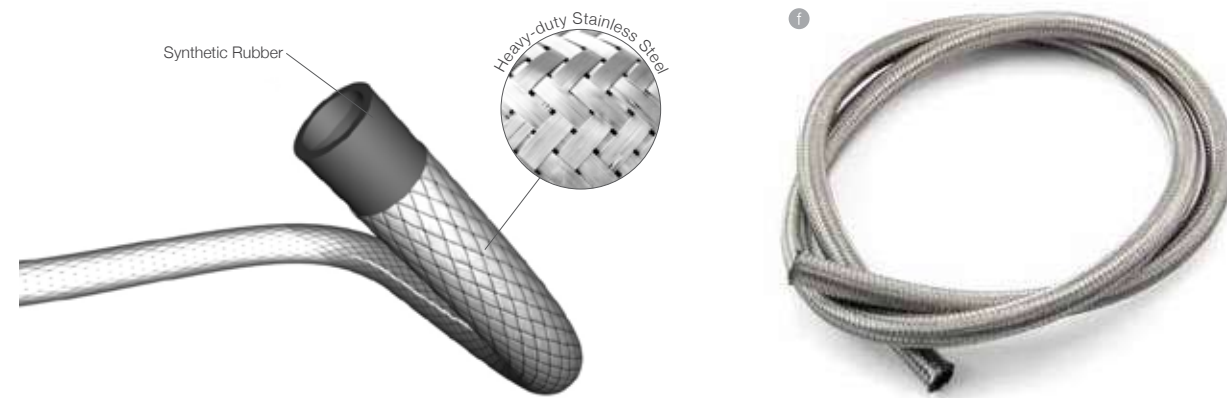

Applications:



Fuel Surge Tanks

Speedmaster™ surge tanks are a great way to help prevent fuel starvation and provide consistent fuel delivery to engines under harsh driving conditions. Our fuel surge tanks hold up to 4 Liters and are TIG Welded 6061 Aluminum.



- a. PCE128.1002 Anodized Aluminum
PCE128.1001 Black Plastic
- b. PCE504.1001 45 Degree Black Aluminum
- c. PCE505.1001 0-90 Ohms 11 in. Tube Style

- d. PCE129.1005 -6 AN Black Anodized
PCE129.1004 -12 AN Blue
PCE129.1003 -10 AN Blue
PCE129.1002 -8 AN Blue
PCE129.1001 -6 AN Blue

- e. PCE337.1007 Aluminum -20 AN
PCE337.1006 -16 AN
PCE337.1005 -12 AN
PCE337.1004 -10 AN
PCE337.1003 -8 AN
PCE337.1002 -6 AN
PCE337.1001 -4 AN

- f. PCE339.1007 Stainless Steel -20 AN
PCE339.1006 -16 AN
PCE339.1005 -12 AN
PCE339.1004 -10 AN
PCE339.1003 -8 AN
PCE339.1002 -6 AN
PCE339.1001 -4 AN

- g. PCE131.1002 Square 1 Gallon / 4 Litre Kit
PCE131.1001 0.5 Gallon / 2 Litre
- h. PCE131.1003 Cylinder 0.5 Gallon / 2 Litre Kit
- i. PCE131.1004 Cylinder 0.75 Gallon / 1.5 Litre Kit

Fuel Pumps

High Flow & Performance

The pump creates positive pressure in the fuel lines, pushing the gasoline to the engine. For different applications and needs check the full range that Speedmaster™ has to offer.

Diaphragm

Speedmaster™ Diaphragm Style Mechanical Fuel Pumps are designed to work with stock or mildly modified engines, and deliver free-flow outputs of 115 gph, that's twice what a normal pump delivers. These pumps are plated with a bright finish for good looks and corrosion resistance, and the lower housings of both can be rotated through 360 degrees, to make fitting into tight places a snap. They have large orifices for high flow rates. These pumps are not compatible with methanol or alcohol fuels, and should not be used with fuel injection systems.



Electric Carb

Speedmaster™ EC100 fuel pumps feature an improved design for street and strip applications. Externally accessible pressure relief valves and repair kits are readily available. Not for use with fuel injection systems.

Speedmaster™ EC400 electric fuel pumps flow over 400 gph. They feature a billet aluminum housing with a hard coat, anodized billet aluminum impeller and high-carbon brushes for long life, low amp draw (only 9.5 amps), and high torque. The fuel pumps offer external line pressure adjustment (10-25 psi), so you can adjust them while running with no fuel mess. They are gasoline and alcohol compatible.

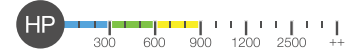

Electric Carb 100



Electric Carb 400



- a. PCE146.1006 Chevy SBC 350 Chrome
PCE146.1007 3/8 NPT
PCE146.1009 1/4 NPT
PCE146.1008 Marine
PCE146.1001 Satin
- b. PCE146.1010 Chevy BBC 454 Chrome
PCE146.1011 3/8 NPT
PCE146.1012 1/4 NPT
PCE146.1002 Satin
- c. PCE146.1013 Ford SB 289 302W Chrome
PCE146.1003 Satin

- d. PCE146.1014 Ford 302 351C Chrome
PCE146.1004 Satin
- e. PCE146.1018 Ford BB 429 460 Chrome
- f. PCE146.1019 Ford FE 390 427 428 Chrome
- g. PCE146.1015 Holden 253 308 Chrome
PCE146.1005 Satin
- h. PCE146.1017 Chevy SBC 350 Polished
PCE146.1016 Satin

- i. PCE144.1001 Universal Billet
- j. PCE145.1001 200 L/Hr EFI 044
- k. PCE145.1008 25 Gph @ 5 psi

Electric Entry Level

EFI

l



PCE392.1001 Ford 289 302 351 Windsor Cleveland (Auto to Manual)

Carb.

k



PCE392.1001 Ford 289 302 351 Windsor Cleveland (Auto to Manual)

Piston-Style

Speedmaster™ Billet Piston fuel pumps operate on a principle similar to a master cylinder, but with an ingenious floating O-ring valve function that continually adjusts to the amount of fuel needed by the engine. This is how Speedmaster™ Billet Piston fuel pumps can be used on any engine from 200-1,200 hp. Speedmaster's variable-stroke piston actually pumps less or more fuel as needed. Because of this variable flow, it doesn't need a bypass-type regulator or return line like traditional constant-pressure pumps do. Speedmaster™ fuel pumps' higher efficiency and variable flow mean that they don't have to work as hard as other pumps and don't add heat to the fuel like conventional diaphragm pumps. Speedmaster™ fuel pumps also consume less horsepower. The fuel pumps for carbureted engines require only 25 lbs. of pushrod pressure, compared to 125 lbs. of pressure for diaphragm pumps.

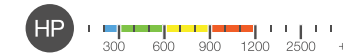

Finish: i

Belt-Driven

Speedmaster™ Belt Driven Fuel Pump is capable of supporting 300 to 2,500 hp, these Speedmaster™ fuel pumps are made just for serious racers. They flow 2,700 lbs./hr. of fuel, deliver 2 to 200 psi worth of fuel pressure, and work with any type of fuel. That's enough fuel flow and pressure to support a 6-second drag car-fuel injected, blown, turbocharged, or otherwise! Their belt-driven design means there's no current draw, and the pumps require no priming.

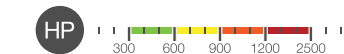

Electric EFI

Speedmaster™ Eruption Fuel Pumps are all in one; durable, reliable, good looking and they support high horsepower. For fuel injected engines up to 2000HP naturally aspirated and up to 1450HP with forced induction. For carbureted engines up to 2200HP naturally aspirated and up to 1650HP with forced induction. E85 and alcohol compatible. Flows up to 1000lbs per hour @ 45 PSI and features AN inlets and outlet ports.

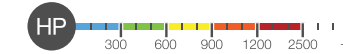

- l. PCE145.1003 95 Gph @ 7 psi Chrome
PCE145.1002 Satin
- m. PCE145.1005 110 Gph @ 14 psi Chrome
PCE145.1004 Satin
- n. PCE145.1019 140 Gph @ 14 psi Red Billet
PCE145.1007 Chrome
PCE145.1006 Satin

- o. PCE145.1013 140 Gph @ 7 psi w/Int. Reg
- p. PCE145.1018 160 Gph @ 7 psi w/Int. Reg

- q. PCE145.1012 400 Gph Billet Black
PCE145.1009 Chrome
PCE145.1010 Red
PCE145.1011 Blue

- r. PCE145.1014 Universal 450 Lbs./Hr.
- s. PCE145.1015 Universal 800 Lbs./Hr.
- t. PCE145.1016 Universal 1000 Lbs./Hr.

Fuel Pumps Accessories

Fuel Pump Mounting Brackets

Speedmaster™ fuel pump mounting brackets are designed to securely mount any Speedmaster™ or Bosh in-line fuel pump. They are made of aluminum and are available in different colors to accent any color fuel pump. They are designed to hold 52mm (2 in.) & 60mm (2.5 in.) diameter fuel pump and filters. Available in single and dual mounting.



Fuel Pump Block-Off Plates

Speedmaster™ fuel pump block off plates are a must when you're switching to an electric fuel pump. Block off the unused port in your engine block where the mechanical pump used to be, with a fancy block-off plate. Offered in a variety of finishes to complement and coordinate with your engine bay accessories.



Fuel Pump Mounting Plates

Speedmaster™ fuel pump mounting plates mount behind your mechanical fuel pump for carbureted small block Chevy V8 and 90 degree V6 engines. They add a touch of shine to the area behind your fuel pump, and even come with a gasket.



Fuel Pump Pushrods

Lightweight fuel pump pushrods from Speedmaster™ feature hardened ends to reduce reciprocating mass, which prevents pump arm float and subsequent fuel starvation. They're ideal for use in drag, Oval Track, and street performance applications.



- | | | |
|--|--|---|
| a. PCE142.1002 EFI Single Red Anodized Alloy
PCE142.1001 Chrome
PCE142.1003 Blue | e. PCE140.1005 Chevy BBC, Ford SB & BB, Chrysler Alloy Red
PCE140.1004 Chrome
PCE140.1006 Blue | h. PCE141.1001 Chevy SBC 283 350 400 |
| b. PCE142.1004 EFI Dual Black Anodized Alloy | f. PCE140.1008 Holden 253 304 308 Alloy Red
PCE140.1007 Chrome
PCE140.1009 Blue | i. PCE143.1001 Chevy SBC 350 Heavy Duty |
| c. PCE142.1005 044 EFI Dual Set Black Anodized Alloy | g. PCE140.1010 Ford 302 351 400 Cleveland Steel | |
| d. PCE140.1002 Chevy SBC 350 Alloy Red
PCE140.1001 Chrome
PCE140.1003 Blue | | |

Fuel Filters Debris-Free

Take fuel, add in dirt and contaminants, and you've got a recipe for disaster. Luckily, our fuel filter selection is ready to keep your fuel system debris-free and your engine running strong and healthy! Choose from inline, canister, clear, and glass styles for carbureted and fuel injected engines—all designed to meet your engine's demands for fuel flow and filtration. Don't put your engine at risk.

Canister Carbureted Engines

Speedmaster™ Canister fuel filters flow up to 90 gph, filter out particles as small as 10 microns, and withstand pressure up to 15 psi. They've got a chrome plated bracket and housing with a 'Billet' or 'die-cast powder-coated' aluminum top and come with a replaceable filter element. They are designed for use with carbureted engines only.

Inline

Speedmaster™ inline filters are terrific inline street filters, which can be easily installed in any stock hose or metal fuel line. Simply cut the existing rubber hose line and insert the inline street filters with two hose clamps. If using a metal line, cut the line and, using two short lengths of rubber hose and four clamps, insert the filter into the line.

Competition

Speedmaster™ Inline fuel filters are manufactured using the best Aircraft Grade Aluminum, and are precision coated with anodizing with the impeccable finish you've come to expect from all Speedmaster™ components. Comes complete with a 100 micron filter with is removable for cleaning.

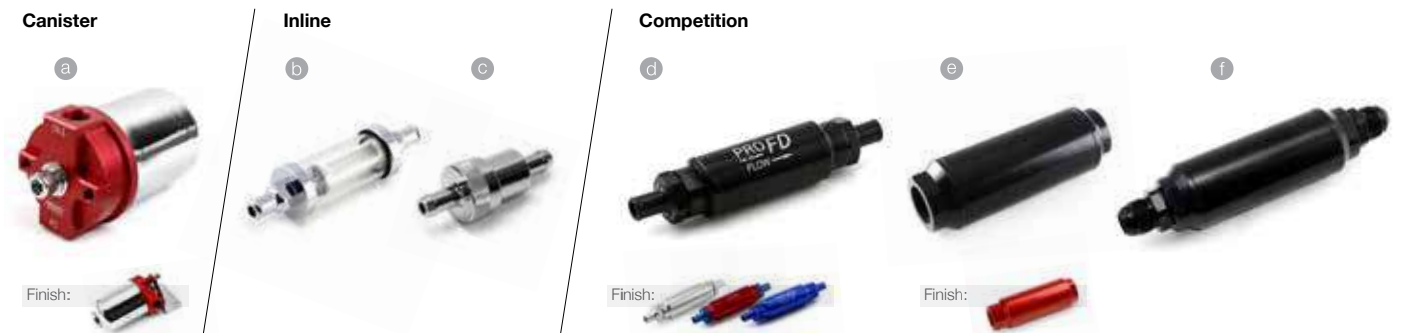

Fuel Filter Replacement Parts

Protect your engine components from costly damage and poor performance by regularly checking and changing your fuel filter element. The tiniest particles can cause issues and Speedmaster™ is here to help with replacement element kits. Don't choke your engine maintain good flow with Speedmaster™ replacement element kits.



- | | |
|--|--|
| a. PCE132.1004 Canister Billet Cap 3/8 NPT Female
PCE132.1005 Cast Cap | e. PCE132.1014 Inline Billet -10 AN Female Black
PCE132.1006 Red |
| b. PCE132.1001 Inline Chrome & Clear 3/8 NPT Male
PCE132.1002 5/16 NPT | f. PCE132.1013 Inline Billet -10 AN Male
PCE132.1012 -8 AN
PCE132.1011 -6 AN |
| c. PCE132.1003 Inline Chrome 3/8 NPT Male | g. PCE133.1001 Kit For PCE132.1004
PCE133.1002 For PCE132.1005 |
| d. PCE132.1009 Inline Billet 3/8 NPT Male Black
PCE132.1010 Silver
PCE132.1007 Red
PCE132.1008 Blue | h. PCE134.1001 Kit for PCE132.1001 & PCE132.1002 |

Fuel Pressure Regulators

Debris-Free

An essential part of the Fuel System, the Fuel Pressure Regulators' sole purpose is to maintain fuel pressure at a constant differential to manifold vacuum under all engine load conditions. The fuel pressure regulator is responsible for controlling the set fuel pressure of the system.



Quick Tip

Dead-Head Carbureted Engines

The needle and seat assemblies that are installed in Speedmaster™ carburetors can sufficiently control fuel pressure up to about 8 psi. If the fuel pump is putting out more than 8 psi, a regulator should be used to keep the fuel pressure within safe limits and avoid the possibility of flooding. Speedmaster™ manufactures a number of regulators for most any need.

Return-Style Carbureted Engines

Speedmaster™ Return-Style regulators are ideal for use with high-volume electric or mechanical fuel pumps, where dynamic flow and rock-steady pressure control are desired. With their high-flow capacity, they're perfect for blow-through carburetor applications with a turbo or centrifugal supercharger.

EFI Boost/Vacuum Reference Port

Speedmaster™ EFI fuel pressure regulators give you total control of your fuel pressure settings. The regulators feature AN O-ring boss inlet, outlet, and return fittings, a 1/8 in. NPT gauge port, and a 1:1 fuel pressure rise from the boost reference port. Speedmaster™ EFI fuel pressure regulators are anodized for great looks and corrosion resistance.

Choosing a Fuel Pressure Regulator

Inlet Fittings

A fuel pressure regulator can come with one or more inlet fittings. A unit with dual inlet regulators is an ideal match for vehicles with more than one fuel rail or for consumers who also want to fit fuel pressure regulators with gauges or sensors.

Vacuum Compensation

Some consumers may also want to look for fuel pressure regulators that have vacuum connections included. These components connect to the inlet manifold, and they keep the pressure differential between the manifold and the fuel rail even and consistent.

Dead-Head



Return-Style



EFI



Pressure Range (psi)	Regulator Location	Boost/Vacuum Reference Port	Gauge Port	Inlet Quantity	Inlet Attachment	Inlet Size	Outlet Quantity	Outlet Attachment	Outlet Size	Regulator Finish	SKU
4 - 9	Inline	No	No	One	Female threads	3/8 in. NPT	Two	Female threads	3/8 in. NPT	Chrome plated	PCE139.1001
										Polished	PCE139.1002
3 - 12	Inline	No	No	One	Female threads	3/8 in. NPT	Two	Female threads	3/8 in. NPT	Red anodized	PCE139.1004
										Blue anodized	PCE139.1005
										Black anodized	PCE139.1006
											PCE139.1007
2 - 14	Inline	No	Yes	One	Male threads	3/8 in. NPT	Two	Male threads	3/8 in. NPT	Black anodized	PCE139.1008
											PCE139.1009
							One	Female threads	-6 AN O-ring	Blue anodized	PCE139.1010
										Black anodized	PCE139.1011
										Red anodized	PCE139.1012
										Blue anodized	PCE139.1013
30 - 70	Inline	Yes	Yes	One	Female threads	-8 AN O-ring	One	Female threads	-8 AN O-ring	Black anodized	PCE139.1014
										Red anodized	PCE139.1015
							One	Female threads	-10 AN O-ring	Blue anodized	PCE139.1016
										Black anodized	PCE139.1017

Fuel Injectors

Speedmaster™ fuel injectors provide precise control of fuel delivery and atomization for increased power, improved throttle response, and better fuel economy.



Ref.	Injector Style	Injector Advertised Flow Rate	SKU
a.	Bosch-Style	24 lbs./hr.	PCE136.1001
		36 lbs./hr.	PCE136.1002
b.	Siemens-Style	60 lbs./hr.	PCE136.1003
		80 lbs./hr.	PCE136.1004

Supercharger Centrifugal Gearbox-Less

The supercharger has proven to be one of the most effective means for obtaining increased power from an internal combustion engine without having to make major engine modifications. This is accomplished by compressing combustion air before it enters the cylinders, which increases density. This results in improved cylinder filling, allowing more air and fuel to be burned in the combustion cycle, with dramatic increases in torque and horsepower. Speedmaster™ has developed its line of centrifugal superchargers to a performance level that has it regarded as the performance and technological leader in aftermarket supercharging.

**+Horsepower
+Torque**



PCE157.1002 P-2 Centrifugal Supercharger Without Gearbox

Speedmaster™ Gearbox-Less Supercharger Features:

- This design allows for supercharger installation and operation without oil lines.
- Extraordinary 78% peak efficiency.
- Ideal for latest generation of improved breathing, high -power street and strip engines.
- Vastly improved flow and efficiency at high boost levels, providing completely new levels of power gain.
- Helical gear design with 3.6:1 step-up.
- Includes remote fluid drain hose (attached to supercharger) that allows for simple fluid changes without removing the supercharger from the vehicle.
- A ventilated gear case assembly eliminates any potential internal pressure issues that are currently associated with non-vented competitive designs.
- Integrated gear case baffling for proper oil control.
- Simple oil slinger design does not require separate shaft or bearing set. This provides proper fluid delivery to gears and bearings.

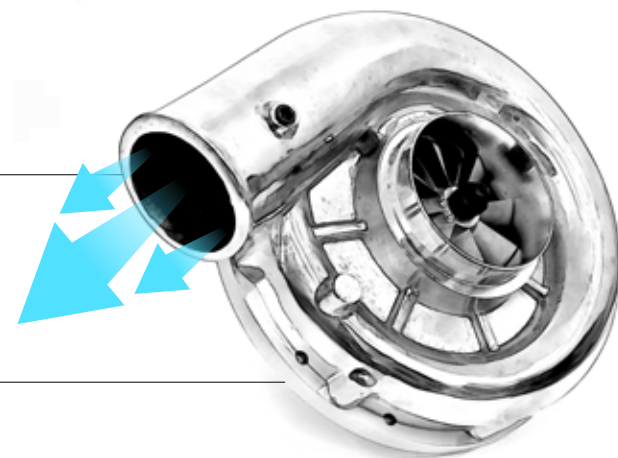

Performance		Dimensions		Overall Size	
Max Speed	52,000 RPM	Discharge OD	2.750 in.	Height	29 cm
Max Boost	22 PSI	Inlet OD	3.500 in.	Length	24 cm
Max Flow	1150 CFM	Discharge ID	2.380 in.	Width	22 cm
Max Power	775 HP	Inducer Diameter	3.100 in.		
Peak Efficiency	78%				

Performance specs apply to units equipped with standard gear case.

Supercharger Roots Style

The supercharger has proven to be one of the most effective means for obtaining increased power from an internal combustion engine without having to make major engine modifications. This is accomplished by compressing combustion air before it enters the cylinders, which increases density. This results in improved cylinder filling, allowing more air and fuel to be burned in the combustion cycle, with dramatic increases in torque and horsepower. Speedmaster™ has developed its line of centrifugal superchargers to a performance level that has it regarded as the performance and technological leader in aftermarket supercharging.

Main Bodies



Nose Drive Assemblies



Idler Brackets & Pulley



Pulleys



Mounting Brackets



Supercharger Roots Style Accessories

All Speedmaster™ Carburetors components are individually tested. These carburetors components are ready to bolt on and go.

Break-away Studs



Drive Belts



Gasket

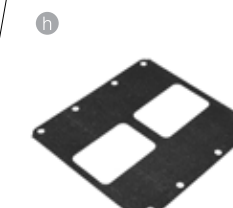

Top Plates



- | | | | |
|----------------|--|----------------|--|
| a. PCE159.1001 | 6-71 Roots Style Supercharger | g. PCE463.1003 | 186 Tooth 1480 Supercharger Blower Drive Belt 8mm |
| b. PCE467.1001 | Supercharger Drive Nose 100mm | PCE463.1004 | 180 Tooth 1440 |
| c. PCE152.1001 | Idler Pulley and Bracket | PCE463.1005 | 170 Tooth 1360 |
| d. PCE155.**** | Supercharger Pulley | h. PCE458.1001 | 6-71 Blower Base Gasket |
| e. PCE154.**** | Blower Crank Support Bracket Kit | i. PCE483.1002 | 6-71 / 8-71 Supercharger to Carburetor Plate Gasket with Screen Mesh |
| f. PCE153.1001 | 6-71 to 14-71 12Pt Break Away Stud Kit | PCE483.1001 | No Screen Mesh |
| | | j. PCE156.1001 | Dual Carb 6-71 8-71 Blower Adapter Plate |

Hose Ends

AN Swivel Hose Ends

Speedmaster™ reusable swivel hose ends are easier to install than cutter-style fittings and are more user-friendly. With their compression-style design, they can be reused without damaging the fitting, and the nipple pilot prevents damage to the inner tube. Their one-piece design allows for improved flow and eliminates two potential leak points (brazed joints). Speedmaster™ fittings are made from 6061 T6 aluminum. Their hex designed taper provides a greater holding area for greater strength and easier assembly. They feature a sharp, double anodizing finish to last for the life of your ride. The mandrel bent tubing provides maximum fluid flow and the compression style design means the fitting is totally reusable. Available in an extensive range of finish options to suit just about any application.



AN Size	Finish	Straight	30 Degree	45 Degree	60 Degree	90 Degree	120 Degree	150 Degree	180 Degree
-4	Black	PCE329.1049	PCE329.1056	PCE329.1062	PCE329.1068	PCE329.1074	PCE329.1080	PCE329.1086	PCE329.1092
	Red/Blue	PCE329.1001	-	PCE329.1008	-	PCE329.1015	-	-	PCE329.1022
	Silver	PCE329.1150	PCE329.1157	PCE329.1163	PCE329.1169	PCE329.1175	PCE329.1181	PCE329.1187	PCE329.1193
-6	Black	PCE329.1050	PCE329.1057	PCE329.1063	PCE329.1069	PCE329.1075	PCE329.1081	PCE329.1087	PCE329.1093
	Red/Blue	PCE329.1002	-	PCE329.1009	-	PCE329.1016	-	-	PCE329.1023
	Silver	PCE329.1151	PCE329.1158	PCE329.1164	PCE329.1170	PCE329.1176	PCE329.1182	PCE329.1188	PCE329.1194
-8	Black	PCE329.1051	PCE329.1058	PCE329.1064	PCE329.1070	PCE329.1076	PCE329.1082	PCE329.1088	PCE329.1094
	Red/Blue	PCE329.1003	-	PCE329.1010	-	PCE329.1017	-	-	PCE329.1024
	Silver	PCE329.1152	PCE329.1159	PCE329.1165	PCE329.1171	PCE329.1177	PCE329.1183	PCE329.1189	PCE329.1195
-10	Black	PCE329.1052	PCE329.1059	PCE329.1065	PCE329.1071	PCE329.1077	PCE329.1083	PCE329.1089	PCE329.1095
	Red/Blue	PCE329.1004	-	PCE329.1011	-	PCE329.1018	-	-	PCE329.1025
	Silver	PCE329.1153	PCE329.1160	PCE329.1166	PCE329.1172	PCE329.1178	PCE329.1184	PCE329.1190	PCE329.1196
-12	Black	PCE329.1053	PCE329.1060	PCE329.1066	PCE329.1072	PCE329.1078	PCE329.1084	PCE329.1090	PCE329.1096
	Red/Blue	PCE329.1005	-	PCE329.1012	-	PCE329.1019	-	-	PCE329.1026
	Silver	PCE329.1154	PCE329.1161	PCE329.1167	PCE329.1173	PCE329.1179	PCE329.1185	PCE329.1191	PCE329.1197
-16	Black	PCE329.1054	PCE329.1061	PCE329.1067	PCE329.1073	PCE329.1079	PCE329.1085	PCE329.1091	PCE329.1097
	Red/Blue	PCE329.1006	-	PCE329.1013	-	PCE329.1020	-	-	PCE329.1027
	Silver	PCE329.1155	PCE329.1162	PCE329.1168	PCE329.1174	PCE329.1180	PCE329.1186	PCE329.1192	PCE329.1198
-20	Black	PCE329.1055	-	-	-	-	-	-	-
	Red/Blue	PCE329.1007	-	PCE329.1014	-	PCE329.1021	-	-	PCE329.1028
	Silver	PCE329.1156	-	-	-	-	-	-	-

Hose Ends

Push Lock Hose Ends

Speedmaster™ Push-Lock swivel hose ends are some of the easiest AN fittings to assemble. Just slip our Speedmaster™ Push-Lock hose over the barbed portion of the hose ends, and assembly is complete. Speedmaster™ fittings are made from 6061 T6 aluminum. The Push-Lock swivel fittings feature a durable, double anodizing finish to stand up to the harshest automotive conditions. The mandrel bent tubing provides maximum fluid flow and the compression style design means the fitting is totally reusable. Available in an extensive range of finish options to suit just about any application.



AN Size	Finish	Straight	30 Degree	45 Degree	60 Degree	90 Degree	120 Degree	150 Degree	180 Degree
-4	Black	PCE329.1110	-	PCE329.1115	-	PCE329.1120	PCE329.1125	PCE329.1130	PCE329.1135
	Blue	PCE329.1029	-	PCE329.1034	-	PCE329.1039	-	-	PCE329.1044
	Silver	PCE329.1199	-	PCE329.1204	-	PCE329.1209	PCE329.1214	PCE329.1219	PCE329.1224
-6	Black	PCE329.1111	-	PCE329.1116	-	PCE329.1121	PCE329.1126	PCE329.1131	PCE329.1136
	Blue	PCE329.1030	-	PCE329.1035	-	PCE329.1040	-	-	PCE329.1045
	Silver	PCE329.1200	-	PCE329.1205	-	PCE329.1210	PCE329.1215	PCE329.1220	PCE329.1225
-8	Black	PCE329.1112	-	PCE329.1117	-	PCE329.1122	PCE329.1127	PCE329.1132	PCE329.1137
	Blue	PCE329.1031	-	PCE329.1036	-	PCE329.1041	-	-	PCE329.1046
	Silver	PCE329.1201	-	PCE329.1206	-	PCE329.1211	PCE329.1216	PCE329.1221	PCE329.1226
-10	Black	PCE329.1113	-	PCE329.1118	-	PCE329.1123	PCE329.1128	PCE329.1133	PCE329.1138
	Blue	PCE329.1032	-	PCE329.1037	-	PCE329.1042	-	-	PCE329.1047
	Silver	PCE329.1202	-	PCE329.1207	-	PCE329.1212	PCE329.1217	PCE329.1222	PCE329.1227
-12	Black	PCE329.1114	-	PCE329.1119	-	PCE329.1124	PCE329.1129	PCE329.1134	PCE329.1139
	Blue	PCE329.1033	-	PCE329.1038	-	PCE329.1043	-	-	PCE329.1048
	Silver	PCE329.1203	-	PCE329.1208	-	PCE329.1213	PCE329.1218	PCE329.1223	PCE329.1228

Coupler Fittings

AN Female Swivel Couplers

Speedmaster™ aluminum couplers connect same-size AN male-threaded together. The couplers have an anodized finish for corrosion resistance.

Black Anodized **Clear Anodized** **Red/Blue Anodized**

Finish:



AN Size	Finish	Straight	45 Degree	90 Degree
-3	Black	PCE328.1079	-	PCE328.1090
	Silver	PCE328.1097	-	PCE328.1108
	Red/Blue	PCE328.1001	-	-
-4	Black	PCE328.1080	-	PCE328.1091
	Silver	PCE328.1098	-	PCE328.1109
	Red/Blue	PCE328.1002	-	-
-6	Black	PCE328.1081	PCE328.1086	PCE328.1092
	Silver	PCE328.1099	PCE328.1104	PCE328.1110
	Red/Blue	PCE328.1003	-	-
-8	Black	PCE328.1082	PCE328.1087	PCE328.1093
	Silver	PCE328.1100	PCE328.1105	PCE328.1111
	Red/Blue	PCE328.1004	-	-
-10	Black	PCE328.1083	PCE328.1088	PCE328.1094
	Silver	PCE328.1101	PCE328.1106	PCE328.1112
	Red/Blue	PCE328.1005	-	-
-12	Black	PCE328.1084	PCE328.1089	PCE328.1095
	Silver	PCE328.1102	PCE328.1107	PCE328.1113
	Red/Blue	PCE328.1006	-	-
-16	Black	PCE328.1085	-	PCE328.1096
	Silver	PCE328.1103	-	PCE328.1114
	Red/Blue	-	-	-



Straight Swivel Coupler

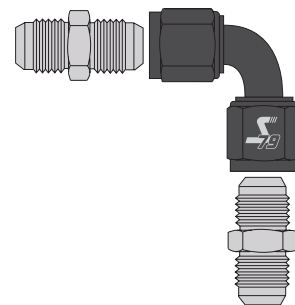

Angle Swivel Coupler

Coupler Fittings

AN Male Flare Couplers

Speedmaster™ aluminum couplers connect same-size AN female-threaded together. The couplers have an anodized finish for corrosion resistance.

Black Anodized **Clear Anodized** **Blue Anodized**

Finish:



AN Size	Finish	Straight	90 Degree
-3	Black	PCE328.1036	PCE328.1043
	Silver	PCE328.1115	PCE328.1122
	Blue	PCE328.1011	-
-4	Black	PCE328.1037	PCE328.1044
	Silver	PCE328.1116	PCE328.1123
	Blue	PCE328.1012	PCE328.1018
-6	Black	PCE328.1038	PCE328.1045
	Silver	PCE328.1117	PCE328.1124
	Blue	PCE328.1013	PCE328.1019
-8	Black	PCE328.1039	PCE328.1046
	Silver	PCE328.1118	PCE328.1125
	Blue	PCE328.1014	PCE328.1020
-10	Black	PCE328.1040	PCE328.1047
	Silver	PCE328.1119	PCE328.1126
	Blue	PCE328.1015	PCE328.1021
-12	Black	PCE328.1041	PCE328.1048
	Silver	PCE328.1120	PCE328.1127
	Blue	PCE328.1016	PCE328.1022
-16	Black	PCE328.1042	PCE328.1049
	Silver	PCE328.1121	PCE328.1128
	Blue	PCE328.1017	PCE328.1023



Straight Flare Coupler

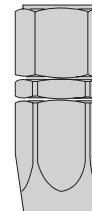



Full Flow Hose End

Coupler Fittings



AN Female Swivel - Male Flare Couplers

Speedmaster™ aluminum couplers connect same-size AN male-threaded and AN female-threaded together. The couplers have an anodized finish for corrosion resistance.

Black Anodized
Clear Anodized

Finish:

AN Size	Finish	45 Degree	90 Degree
-3	Black	PCE328.1073	PCE328.1067
	Silver	PCE328.1135	PCE328.1129
-4	Black	PCE328.1074	PCE328.1068
	Silver	PCE328.1136	PCE328.1130
-6	Black	PCE328.1075	PCE328.1069
	Silver	PCE328.1137	PCE328.1131
-8	Black	PCE328.1076	PCE328.1070
	Silver	PCE328.1138	PCE328.1132
-10	Black	PCE328.1077	PCE328.1071
	Silver	PCE328.1139	PCE328.1133
-12	Black	PCE328.1078	PCE328.1072
	Silver	PCE328.1140	PCE328.1134

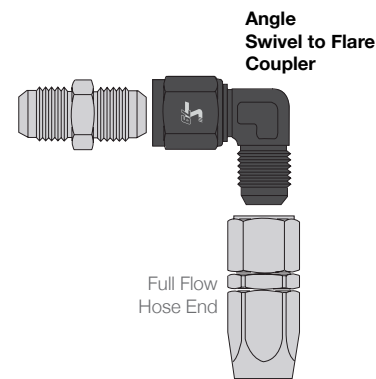

Coupler Fittings

NPT Female Pipe Couplers

Speedmaster™ aluminum couplers connect same-size NPT male-threaded pipe together. The couplers have an anodized finish for corrosion resistance.

Black Anodized
Clear Anodized
Blue Anodized





Finish:

NPT Size	Black	Silver	Blue
1/8"	PCE328.1050	PCE328.1141	PCE328.1030
1/4"	PCE328.1051	PCE328.1142	PCE328.1031
3/8"	PCE328.1052	PCE328.1143	PCE328.1032
1/2"	PCE328.1053	PCE328.1144	PCE328.1033
3/4"	PCE328.1054	PCE328.1145	PCE328.1034
1"	-	-	PCE328.1035

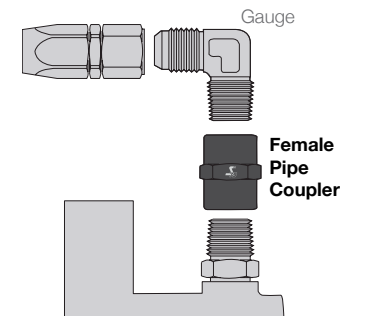

NPT Male Pipe Couplers

Speedmaster™ aluminum couplers connect same-size NPT female-threaded together. The couplers have an anodized finish for corrosion resistance.

Black Anodized
Clear Anodized
Blue Anodized





Finish:

NPT Size	Black	Silver	Blue
1/8"	PCE328.1055	PCE328.1146	PCE328.1024
1/4"	PCE328.1056	PCE328.1147	PCE328.1025
3/8"	PCE328.1057	PCE328.1148	PCE328.1026
1/2"	PCE328.1058	PCE328.1149	PCE328.1027
3/4"	PCE328.1059	PCE328.1150	PCE328.1028
1"	PCE328.1060	PCE328.1151	PCE328.1029

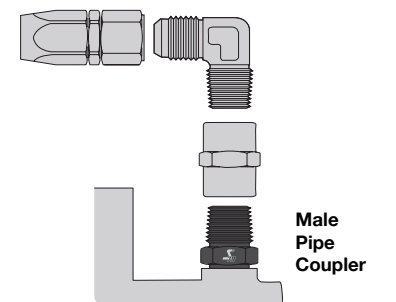

Coupler Fittings

NPT Female - Male Pipe Couplers

Speedmaster™ aluminum couplers connect same-size NPT male-threaded pipe and NPT female-threaded together. The couplers have an anodized finish for corrosion resistance.

Black Anodized

Clear Anodized

Finish:



NPT Size	Finish	45 Degree	90 Degree
1/8"	Black	PCE328.1064	PCE328.1061
	Silver	PCE328.1155	PCE328.1152
1/4"	Black	PCE328.1065	PCE328.1062
	Silver	PCE328.1156	PCE328.1153
3/8"	Black	PCE328.1066	PCE328.1063
	Silver	PCE328.1157	PCE328.1154

Full Flow
Hose End

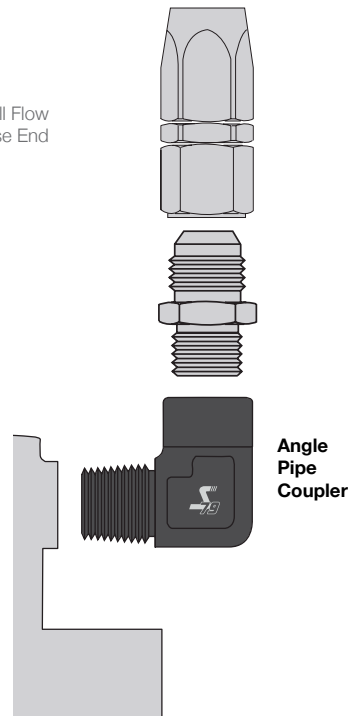

**Angle
Pipe
Coupler**

Reducers

AN Male Flare Reducers

Speedmaster™ aluminum reducers allow you to connect dissimilar-sized AN flare lines to other AN flare line or components. The reducers have an anodized finish for corrosion resistance.

Black Anodized

Clear Anodized

Blue Anodized

Finish:



Flare to Flare	Black	Silver	Blue
-4 to -3	PCE333.1061	PCE333.1073	PCE333.1001
-6 to -4	PCE333.1062	PCE333.1074	PCE333.1002
-6 to -5	PCE333.1063	PCE333.1075	-
-8 to -4	PCE333.1064	PCE333.1076	-
-8 to -6	PCE333.1065	PCE333.1077	PCE333.1003
-10 to -6	PCE333.1066	PCE333.1078	PCE333.1004
-10 to -8	PCE333.1067	PCE333.1079	PCE333.1005
-12 to -6	PCE333.1068	PCE333.1080	PCE333.1006
-12 to -8	PCE333.1069	PCE333.1081	PCE333.1007
-12 to -10	PCE333.1070	PCE333.1082	PCE333.1008
-16 to -10	PCE333.1071	PCE333.1083	PCE333.1009
-16 to -12	PCE333.1072	PCE333.1084	PCE333.1010
-20 to -12	-	-	PCE333.1011
-20 to -16	-	-	PCE333.1012

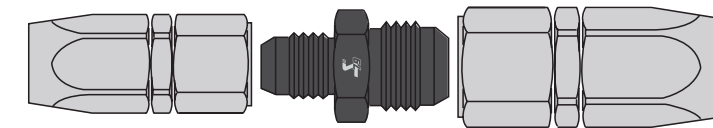

**Male
Flare to Flare
Reducer**

Reducers

AN Female to Male Flare Reducers

Speedmaster™ aluminum reducers allow you to connect dissimilar-sized AN flare lines to other AN flare line or components. The reducers have an anodized finish for corrosion resistance.



Female	Male	Black	Silver	Blue
-4	-3	PCE333.1041	PCE333.1085	PCE333.1026
-6	-3	-	-	PCE333.1027
-6	-4	PCE333.1042	PCE333.1086	PCE333.1028
-8	-6	PCE333.1044	PCE333.1087	PCE333.1029
-10	-6	PCE333.1045	PCE333.1088	PCE333.1030
-10	-8	PCE333.1046	PCE333.1089	PCE333.1031
-12	-8	-	-	PCE333.1032
-12	-10	PCE333.1047	PCE333.1090	PCE333.1033
-16	-12	PCE333.1048	PCE333.1091	PCE333.1034

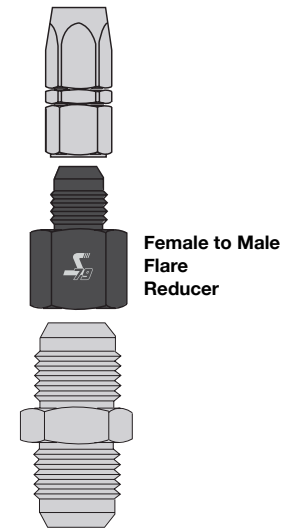

AN Female to Male Flare Expander

Speedmaster™ aluminum reducers allow you to connect dissimilar-sized AN flare lines to other AN flare line or components. The reducers have an anodized finish for corrosion resistance.



Female	Male	Black	Silver	Blue
-3	-4	-	-	PCE333.1035
-4	-6	-	-	PCE333.1036
-6	-8	PCE333.1043	PCE333.1092	PCE333.1037
-8	-10	-	-	PCE333.1038
-10	-12	-	-	PCE333.1039
-12	-16	-	-	PCE333.1040

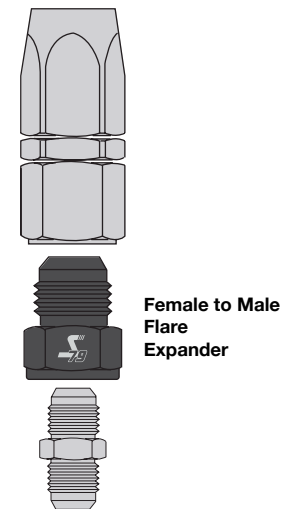

Reducers

NPT Male to Female Pipe Reducers

Speedmaster™ aluminum reducers allow you to connect dissimilar-sized NPT pipe lines to other NPT pipe line or components. The reducers have an anodized finish for corrosion resistance.



Male	Female	Black	Silver	Blue
1/4"	1/8"	PCE333.1049	PCE333.1093	PCE333.1013
3/8"	1/8"	PCE333.1050	PCE333.1094	PCE333.1014
3/8"	1/4"	PCE333.1051	PCE333.1095	PCE333.1015
1/2"	1/8"	PCE333.1052	PCE333.1096	PCE333.1016
1/2"	1/4"	PCE333.1053	PCE333.1097	PCE333.1017
1/2"	3/8"	PCE333.1054	PCE333.1098	PCE333.1018
3/4"	1/4"	PCE333.1055	PCE333.1099	PCE333.1019
3/4"	3/8"	PCE333.1056	PCE333.1100	PCE333.1020
3/4"	1/2"	PCE333.1057	PCE333.1101	PCE333.1021
1"	3/8"	PCE333.1058	PCE333.1102	PCE333.1022
1"	1/2"	PCE333.1059	PCE333.1103	PCE333.1023
1"	3/4"	PCE333.1060	PCE333.1104	PCE333.1024
1-1/4"	3/4"	-	-	PCE333.1025

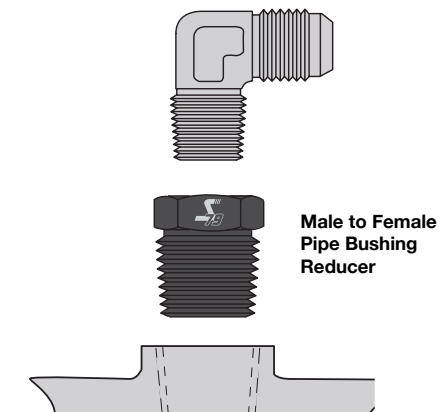

Plug and Cap Fittings

AN Flare Caps

Speedmaster™ AN flare caps prevent dirt and debris from entering externally threaded hose fittings and adapters. Features include the ability to seal automotive-type fluids, lightweight aluminum construction, and a great looking anodized finish.

Finish:

Black Anodized



Clear Anodized



Blue Anodized



AN Size	Black	Silver	Blue
-3	PCE327.1008	PCE327.1015	PCE327.1001
-4	PCE327.1009	PCE327.1016	PCE327.1002
-6	PCE327.1010	PCE327.1017	PCE327.1003
-8	PCE327.1011	PCE327.1018	PCE327.1004
-10	PCE327.1012	PCE327.1019	PCE327.1005
-12	PCE327.1013	PCE327.1020	PCE327.1006
-16	PCE327.1014	PCE327.1021	PCE327.1007

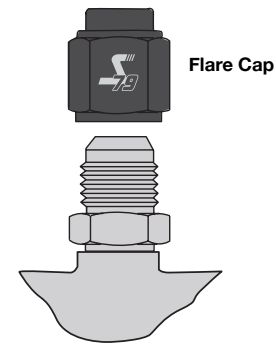

Plug and Cap Fittings

Hex Head ORB Port Plugs

Speedmaster™ AN plugs are ideal for sealing fittings and ports. Features include lightweight aluminum construction, and a great looking anodized finish.

Finish:

Black Anodized



Clear Anodized



Blue Anodized



AN Size	Black	Silver	Blue
-3	PCE331.1030	PCE331.1050	PCE331.1008
-4	PCE331.1031	PCE331.1051	PCE331.1009
-6	PCE331.1032	PCE331.1052	PCE331.1010
-8	PCE331.1033	PCE331.1053	PCE331.1011
-10	PCE331.1034	PCE331.1054	PCE331.1012
-12	PCE331.1035	PCE331.1055	PCE331.1013
-16	PCE331.1036	PCE331.1056	PCE331.1014

Hex Head AN Flare Plugs

Speedmaster™ AN plugs are ideal for sealing fittings and ports. Features include lightweight aluminum construction, and a great looking anodized finish.

Finish:

Black Anodized



Clear Anodized



Blue Anodized



AN Size	Black	Silver	Blue
-3	PCE331.1023	PCE331.1043	PCE331.1001
-4	PCE331.1024	PCE331.1044	PCE331.1002
-6	PCE331.1025	PCE331.1045	PCE331.1003
-8	PCE331.1026	PCE331.1046	PCE331.1004
-10	PCE331.1027	PCE331.1047	PCE331.1005
-12	PCE331.1028	PCE331.1048	PCE331.1006
-16	PCE331.1029	PCE331.1049	PCE331.1007

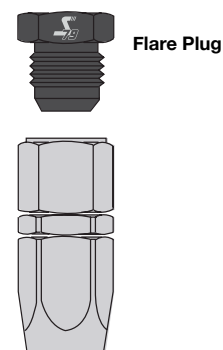

Allen Head NPT Pipe Plugs

Speedmaster™ NPT plugs are ideal for sealing fittings and ports. Features include lightweight aluminum construction, and a great looking anodized finish.

Finish:

Black Anodized



Clear Anodized



Blue Anodized



NPT Size	Black	Silver	Blue
1/16"	-	-	PCE331.1015
1/8"	PCE331.1037	PCE331.1057	PCE331.1016
1/4"	PCE331.1038	PCE331.1058	PCE331.1017
3/8"	PCE331.1039	PCE331.1059	PCE331.1018
1/2"	PCE331.1040	PCE331.1060	PCE331.1019
3/4"	PCE331.1041	PCE331.1061	PCE331.1020
1"	PCE331.1042	PCE331.1062	PCE331.1021

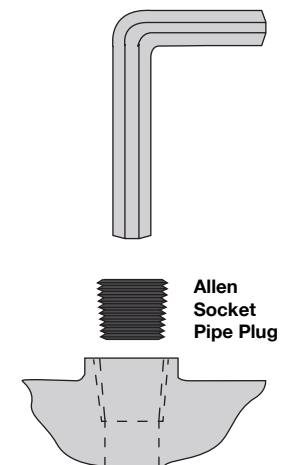

AN to NPT Fittings

AN Male to NPT Male Adapters

Speedmaster™ aluminum AN to NPT adapter fittings will make almost any plumbing project on your vehicle easier. Speedmaster's AN to NPT adapter fittings are the third and final step to completing your hose assembly. The AN side of the fittings uses a 37 degree sealing angle that guarantees a positive seal at maximum operating pressures. These fittings are available in straight, 45 degree, and 90 degree styles.



AN Size	NPT Size	Finish	Straight	45 Degree	90 Degree
-3	1/8"	Black	PCE324.1044	PCE324.1087	PCE324.1066
		Silver	PCE324.1122	PCE324.1165	PCE324.1144
		Blue	-	PCE324.1035	PCE324.1019
-3	1/4"	Black	PCE324.1045	PCE324.1088	PCE324.1067
		Silver	PCE324.1123	PCE324.1166	PCE324.1145
		Blue	-	-	-
-4	1/8"	Black	PCE324.1046	PCE324.1089	PCE324.1068
		Silver	PCE324.1124	PCE324.1167	PCE324.1146
		Blue	PCE324.1001	PCE324.1036	PCE324.1020
-4	1/4"	Black	PCE324.1047	PCE324.1090	PCE324.1068
		Silver	PCE324.1125	PCE324.1168	PCE324.1147
		Blue	PCE324.1003	-	PCE324.1021
-4	3/8"	Black	PCE324.1048	PCE324.1091	PCE324.1070
		Silver	PCE324.1126	PCE324.1169	PCE324.1148
		Blue	-	-	-
-6	1/8"	Black	PCE324.1049	PCE324.1092	PCE324.1071
		Silver	PCE324.1127	PCE324.1170	PCE324.1149
		Blue	PCE324.1002	PCE324.1038	PCE324.1023
-6	1/4"	Black	PCE324.1050	PCE324.1093	PCE324.1072
		Silver	PCE324.1128	PCE324.1171	PCE324.1150
		Blue	PCE324.1004	PCE324.1037	PCE324.1022
-6	3/8"	Black	PCE324.1051	PCE324.1094	PCE324.1073
		Silver	PCE324.1129	PCE324.1172	PCE324.1151
		Blue	PCE324.1005	PCE324.1043	PCE324.1024
-6	1/2"	Black	PCE324.1052	PCE324.1095	PCE324.1074
		Silver	PCE324.1130	PCE324.1173	PCE324.1152
		Blue	PCE324.1006	PCE324.1039	PCE324.1025
-8	1/4"	Black	PCE324.1053	PCE324.1096	PCE324.1075
		Silver	PCE324.1131	PCE324.1174	PCE324.1153
		Blue	PCE324.1008	-	PCE324.1027

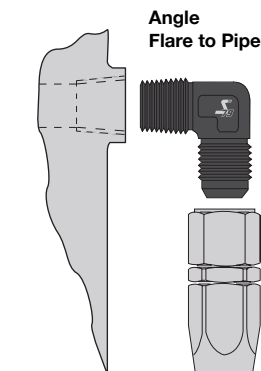
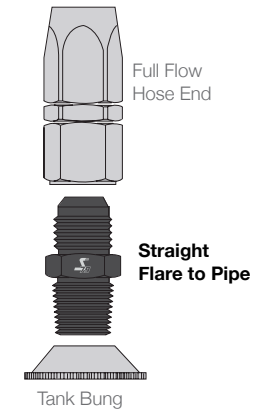

AN Size	NPT Size	Finish	Straight	45 Degree	90 Degree
-8	3/8"	Black	PCE324.1054	PCE324.1097	PCE324.1076
		Silver	PCE324.1132	PCE324.1175	PCE324.1154
		Blue	PCE324.1007	PCE324.1040	PCE324.1026
-8	1/2"	Black	PCE324.1055	PCE324.1098	PCE324.1077
		Silver	PCE324.1133	PCE324.1176	PCE324.1155
		Blue	PCE324.1009	-	-
-8	3/4"	Black	PCE324.1056	PCE324.1099	PCE324.1078
		Silver	PCE324.1134	PCE324.1177	PCE324.1156
		Blue	PCE324.1010	-	-
-10	3/8"	Black	PCE324.1057	PCE324.1100	PCE324.1079
		Silver	PCE324.1135	PCE324.1178	PCE324.1157
		Blue	PCE324.1012	-	PCE324.1029
-10	1/2"	Black	PCE324.1058	PCE324.1101	PCE324.1080
		Silver	PCE324.1136	PCE324.1179	PCE324.1158
		Blue	PCE324.1011	PCE324.1041	PCE324.1028
-10	3/4"	Black	PCE324.1059	PCE324.1102	PCE324.1081
		Silver	PCE324.1137	PCE324.1180	PCE324.1159
		Blue	PCE324.1013	-	PCE324.1030
-12	1/2"	Black	PCE324.1060	PCE324.1103	PCE324.1082
		Silver	PCE324.1138	PCE324.1181	PCE324.1160
		Blue	PCE324.1015	-	PCE324.1032
-12	3/4"	Black	PCE324.1061	PCE324.1104	PCE324.1083
		Silver	PCE324.1139	PCE324.1182	PCE324.1161
		Blue	PCE324.1014	PCE324.1042	PCE324.1031
-12	1"	Black	PCE324.1062	PCE324.1105	PCE324.1084
		Silver	PCE324.1140	PCE324.1183	PCE324.1162
		Blue	PCE324.1016	-	-
-16	3/4"	Black	PCE324.1063	PCE324.1106	PCE324.1085
		Silver	PCE324.1141	PCE324.1184	PCE324.1163
		Blue	PCE324.1018	PCE324.1034	PCE324.1033
-16	1"	Black	PCE324.1064	PCE324.1107	PCE324.1086
		Silver	PCE324.1142	PCE324.1185	PCE324.1164
		Blue	PCE324.1017	-	-
-20	1 1/4"	Black	PCE324.1065	-	-
		Silver	PCE324.1143	-	-
		Blue	-	-	-

Continued

AN to NPT Fittings

AN Female to NPT Male Adapters

Speedmaster™ aluminum AN to NPT adapter fittings will make almost any plumbing project on your vehicle easier. Speedmaster's AN to NPT adapter fittings are the third and final step to completing your hose assembly.

Black Anodized

Clear Anodized

Finish:



AN Size	NPT Size	Black	Silver
-3	1/8"	PCE324.1108	PCE324.1186
-4	1/8"	PCE324.1109	PCE324.1187
-4	1/4"	PCE324.1110	PCE324.1188
-6	1/8"	PCE324.1111	PCE324.1189
-6	1/4"	PCE324.1112	PCE324.1190
-6	3/8"	PCE324.1113	PCE324.1191
-8	1/4"	PCE324.1114	PCE324.1192
-8	3/8"	PCE324.1115	PCE324.1193
-8	1/2"	PCE324.1116	PCE324.1194
-10	3/8"	PCE324.1117	PCE324.1195
-10	1/2"	PCE324.1118	PCE324.1196
-12	1/2"	PCE324.1119	PCE324.1197
-12	3/4"	PCE324.1120	PCE324.1198

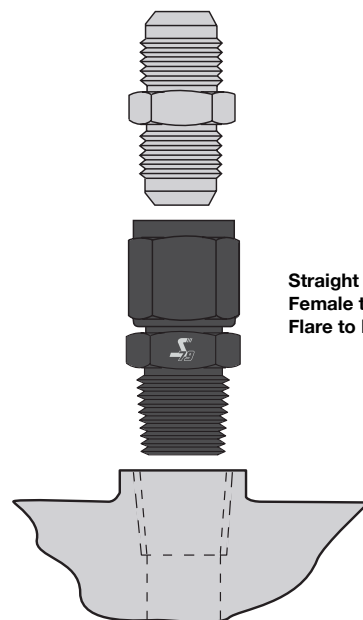

**Straight
Female to Male
Flare to Pipe**

AN to Metric Adapter Fittings

Speedmaster™ AN to metric adapter fittings are manufactured from lightweight, quality aluminum to exacting standards for tight, leak-free connections and then anodized for durability. These AN to metric adapter fittings are available in varying sizes to fit nearly any application.

Black Anodized

Clear Anodized

Blue Anodized

Finish:



AN Size	Metric Thread	Black	Silver	Blue
-4	8mm x 1.0	PCE322.1008	PCE322.1046	-
-4	8mm x 1.25	PCE322.1009	PCE322.1047	-
-4	10mm x 1.0	PCE322.1010	PCE322.1048	-
-4	10mm x 1.25	PCE322.1011	PCE322.1049	-
-4	10mm x 1.5	PCE322.1012	PCE322.1050	-
-4	12mm x 1.0	PCE322.1013	PCE322.1051	-
-4	12mm x 1.25	PCE322.1014	PCE322.1052	-
-4	12mm x 1.5	PCE322.1015	PCE322.1053	-
-4	14mm x 1.25	PCE322.1016	PCE322.1054	-
-4	14mm x 1.5	PCE322.1017	PCE322.1055	-
-6	10mm x 1.0	PCE322.1018	PCE322.1056	-
-6	10mm x 1.25	PCE322.1019	PCE322.1057	-
-6	10mm x 1.5	PCE322.1020	PCE322.1058	-
-6	12mm x 1.0	PCE322.1021	PCE322.1059	-
-6	12mm x 1.25	PCE322.1022	PCE322.1060	-
-6	12mm x 1.5	PCE322.1023	PCE322.1061	-
-6	14mm x 1.25	PCE322.1024	PCE322.1062	-
-6	14mm x 1.5	PCE322.1025	PCE322.1063	PCE322.1001
-6	16mm x 1.5	PCE322.1026	PCE322.1064	-
-6	18mm x 1.5	PCE322.1027	PCE322.1065	PCE322.1004
-6	20mm x 1.5	PCE322.1028	PCE322.1066	-
-8	12mm x 1.5	PCE322.1029	PCE322.1067	-
-8	14mm x 1.5	PCE322.1030	PCE322.1068	PCE322.1002
-8	16mm x 1.5	PCE322.1031	PCE322.1069	-
-8	18mm x 1.5	PCE322.1032	PCE322.1070	PCE322.1005
-8	20mm x 1.5	PCE322.1033	PCE322.1071	-
-10	14mm x 1.5	PCE322.1034	PCE322.1072	PCE322.1003
-10	16mm x 1.5	PCE322.1035	PCE322.1073	-
-10	18mm x 1.5	PCE322.1036	PCE322.1074	PCE322.1006
-10	20mm x 1.5	PCE322.1037	PCE322.1075	-
-10	22mm x 1.5	PCE322.1038	PCE322.1076	-
-10	24mm x 1.5	PCE322.1039	PCE322.1077	-
-12	14mm x 1.5	PCE322.1040	PCE322.1078	-
-12	16mm x 1.5	PCE322.1041	PCE322.1079	-
-12	18mm x 1.5	PCE322.1042	PCE322.1080	-
-12	20mm x 1.5	PCE322.1043	PCE322.1081	-
-12	22mm x 1.5	PCE322.1044	PCE322.1082	-
-12	24mm x 1.5	PCE322.1045	PCE322.1083	-

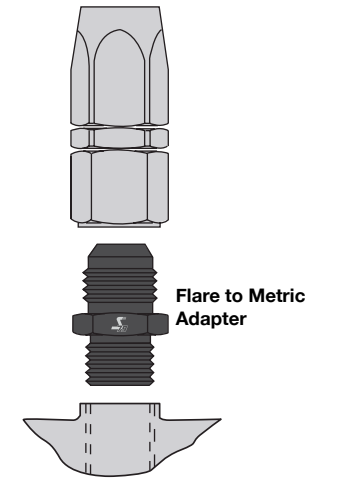

**Flare to Metric
Adapter**

AN Flare to AN ORB (High Flow Radius) Adapters

Speedmaster™ radius port adapter fittings are precision machined for positive thread engagement. They feature radius profiled angles at port inlet/outlet for optimum flow. These adapters are ideal when connecting regulators and fuel lines to pumps and tanks, and are also useful for dry sump applications. An anodized finish is applied for appearance and durability.

Black Anodized **Clear Anodized** **Blue Anodized**

Finish:



AN Size	AN ORB Size	Black	Silver	Blue
-4	-4	PCE325.1008	PCE325.1023	PCE325.1001
-6	-6	PCE325.1009	PCE325.1024	PCE325.1002
-6	-8	PCE325.1010	PCE325.1025	PCE325.1003
-6	-10	PCE325.1011	PCE325.1026	-
-8	-6	PCE325.1012	PCE325.1027	PCE325.1004
-8	-8	PCE325.1013	PCE325.1028	PCE325.1005
-8	-10	PCE325.1014	PCE325.1029	PCE325.1006
-10	-8	PCE325.1015	PCE325.1030	-
-10	-10	PCE325.1016	PCE325.1031	PCE325.1007
-10	-12	PCE325.1017	PCE325.1032	-
-12	-10	PCE325.1018	PCE325.1033	-
-12	-12	PCE325.1019	PCE325.1034	-
-12	-16	PCE325.1020	PCE325.1035	-
-16	-12	PCE325.1021	PCE325.1036	-
-16	-16	PCE325.1022	PCE325.1037	-

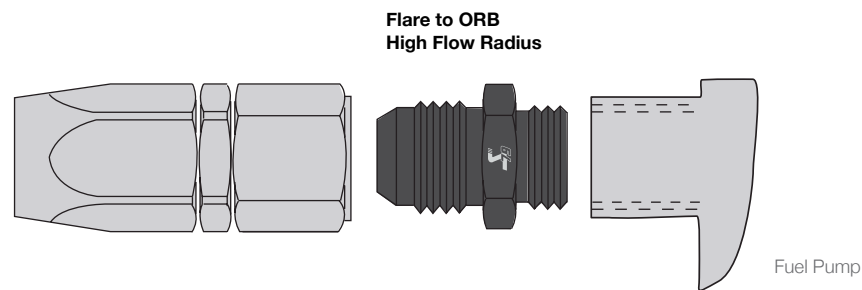

AN to Tube Adapter Fittings

Speedmaster™ AN to tube adapter fittings allow the easy connection of AN-type braided hose to aluminum tubing. The durable aluminum fittings use a screw-together compression fitting that is compatible with low-pressure fluid transfer applications. They're available with both male and female ends and multiple sizes to suit your application.

Tube to Female

Red/Blue Anodized



Tube Size	AN Size	SKU
5/16"	-6	PCE326.1005
3/8"	-6	PCE326.1006
1/2"	-8	PCE326.1007
5/8"	-10	PCE326.1008

Tube to Male

Red/Blue Anodized



Tube Size	AN Size	SKU
5/16"	-6	PCE326.1001
3/8"	-6	PCE326.1002
1/2"	-8	PCE326.1003
5/8"	-10	PCE326.1004

Carburetor Inlet Fittings

Designed to provide an easy connection to hose ends, these high-quality carburetor and fuel pump adapters from Speedmaster™ make it easy to plumb your fuel system.



PCE506.1001 Hi Flow Inlet Banjo/Hose Fitting Kit Black Anodized Aluminum

Hose & Line & Tubing

Hose Sleeving Kits

Speedmaster™ hose sleeving kits are the answer to protecting your engine hoses for added reliability. They provide an affordable alternative to stainless steel and will give your car that authentic race look. Speedmaster hose sleeving kits are designed for easy slip-on installation. They contain enough braided metal sleeving in various sizes to cover the upper radiator hose, heater hoses, and fuel and vacuum hoses. They come complete with an anodized aluminum hose clamp cover in your choice of red, blue, black or chrome for a professional, finished appearance.

The kit includes:

- 3 ft. of vacuum line sleeving
- 4 ft. of fuel line sleeving and 4 Hose ends
- 4 ft. of radiator hose sleeving and 4 Hose ends
- 12 ft. of heater hose sleeving and 2 Hose ends



Finish:



Hose Cover Material	Hose Cover Finish	Clamps Included	Hose Clamp Covers Included	Hose Clamp Cover Finish	SKU
Stainless steel	Natural	No	Yes	Chrome	PCE343.1001
				Red anodized	PCE343.1002
				Blue anodized	PCE343.1003
				Black anodized	PCE343.1004



Hoses, Radiator

Make cooling your car an easier task by using Speedmaster™ universal flexible radiator hose kits. These stainless steel universal flexible radiator hose kits are offered in several size options, making them perfect for custom applications. Speedmaster™ universal flexible radiator hose kits are strong, stylish replacements for weak factory rubber hoses. Speedmaster stainless steel flexible hoses bend and cut easily, are non-corrosive, and dissipate heat better than rubber hoses. Stainless steel clamps and reducer inserts are included.



Ref.	Hose Length (in)	Hose Material	Hose Finish	Hose Clamps Included	Hose Clamp Covers Included	Hose Clamp Cover Material	Hose Clamp Cover Finish	SKU
a.	12 in.	Stainless steel	Chrome	Yes	Yes	Aluminum	Chrome	PCE344.1001
b.	24 in.	Stainless steel	Chrome	Yes	Yes	Aluminum	Chrome	PCE344.1002
c.	36 in.	Stainless steel	Chrome	Yes	Yes	Aluminum	Chrome	PCE344.1003
d.	48 in.	Stainless steel	Chrome	Yes	Yes	Aluminum	Chrome	PCE344.1004

Brake Hoses, Individual

Speedmaster™ universal pre-assembled brake hose assemblies are constructed from PowerFlex stainless steel braided hose. The ends are factory-crimped to eliminate leakag.



Ref.	Hose End	Assembled	Length (in)	Brake Hose Outer Material	SKU
a.	10mm or 3/8 in. banjo	Yes	18.000 in.	Rubber	PCE496.1001
b.	10mm or 3/8 in. banjo	Yes	18.000 in.	Raided stainless steel	PCE496.1002
b.	12mm or 7/16 in. banjo	Yes	18.000 in.	Raided stainless steel	PCE496.1003

Technical Information

AN Thread (JIC)

AN stands for Army/Navy and is the standard for many hydraulic lines used in performance hoses and accessories. AN thread sizes start at -2 up to -32, but the most common sizes are -3 to -20. The AN fittings are also known as JIC and have a UNF thread. These fittings are very popular to connect flexible hoses to accessories or hard line tube that carry different types of fluid. There are two common angles used in flare fittings, 37 degree and 45 degree. The fittings use these angle faces to form a seal and this must always be checked as they are not interchangeable. It is important to make sure these faces are not damaged to avoid leakage at the flare. All AN threads are parallel and are basically a flare fitting with the 37 degree face machined off and a groove for the o ring machined. This o ring now seals the connection. The performance industry now uses a lot of AN-ORB ports in many applications due to it being higher flowing and better sealing than NPT



National Pipe Thread (NPT)

The NPT thread has been popular for low pressure hydraulics for many years. NPT fittings and ports have a tapered thread and start loose and then tighten up as the wedging of the threads seals the connection. This style of union looks bulkier as the fitting does not screw all the way up. A thread sealant either liquid or tape is recommended to ensure the connection does no leak.

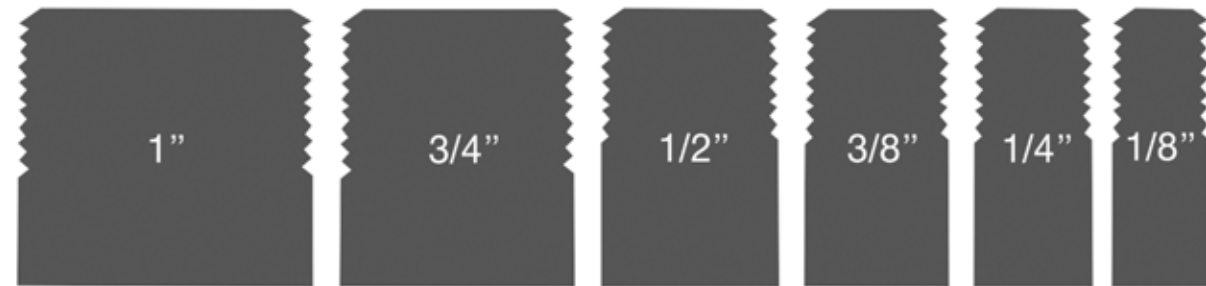

National Pipe Thread (NPT)

Many vehicles today have metric threads and sometimes are a little confusing, most have an o ring or a washer to seal the connection. Speedmaster™ have many metric adaptors and fittings for these applications

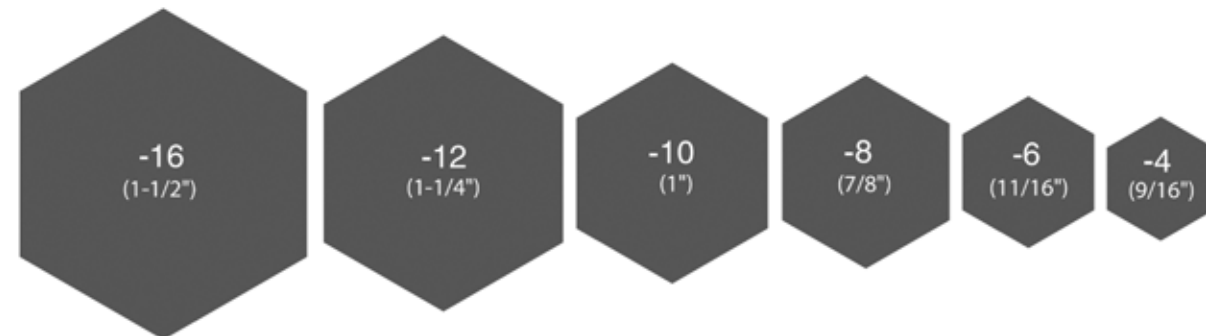

Technical information

NPT (National Pipe Thread)			AN Thread (JIC)				AN Nut (JIC)		
Thread Size	Thread per Inch	Closest AN SIZE	Thread Size	Thread per Inch	Closest AN SIZE	Max Torque	Hex Size	B Nut AN Side	S Nut Hose Side
1/8"	27	AN-4	-3	3/8"	24	8.75	-3	1/2"	-
1/4"	18	AN-6	-4	7/16"	20	11.5	-4	9/16"	23/32"
3/8"	18	AN-8	-5	1/2"	20	14.3	-6	11/16"	7/8"
1/2"	14	AN-10	-6	9/16"	18	16.25	-8	7/8"	1 1/32"
3/4"	14	AN-12	-8	3/4"	16	29	-10	1"	1 7/32"
1"	11.5	AN-16	-10	7/8"	14	35	-12	1 1/4"	1 7/16"
1-1/4"	11.5	AN-20	-12	1 1/16"	12	45	-16	1 1/2"	1 3/4"
			-16	1 5/16"	12	70	-20	2"	2 5/16"
			-20	1 5/8"	12	85			

Hose Application Guide

Hose Size	NPT (National Pipe Thread)				Application
	100 & 450 Series	200 Series	400 Series	525 Series	
-3	-	Yes	-	-	Brake, gauge lines & oil lines
-4	Yes	Yes	Yes	Yes	Oil lines, gauge lines and Vacuum lines
-5	-	-	Yes	Yes	Fuel and vacuum lines
-6	Yes	Yes	Yes	Yes	Water, fuel & oil lines
-8	Yes	Yes	Yes	Yes	Water, fuel & oil lines
-10	Yes	-	Yes	Yes	Water, fuel & oil lines
-12	Yes	-	Yes	Yes	Water, fuel & oil lines
-16	Yes	-	-	Yes	Water & oil lines
-20	Yes	-	-	-	Water

* Not recommended for E85 & exotic fuels

Turbo Fitting Guide

Water	Oil Feed	Oil Drain	Application
PFD732	PFD341	PFD676	GT25, GT28, GT30 & GT35
PFD734	PFD675	PFD676	GT37, GT40, GT42 & GT45
	PFD675	PFD676	GT32, GT47, GT55 & GT60

Assembly

AN Swivel Hose Ends

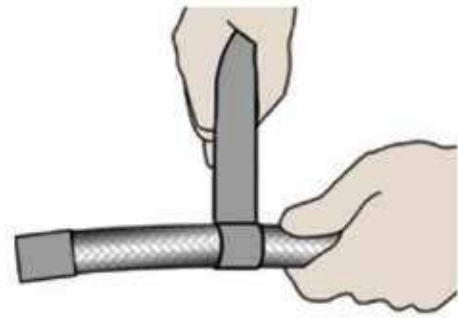

1. Wrap masking or electrical tape around stainless braided hose to stop fraying. Then cut hose square with a fine cut off wheel or fine hacksaw.

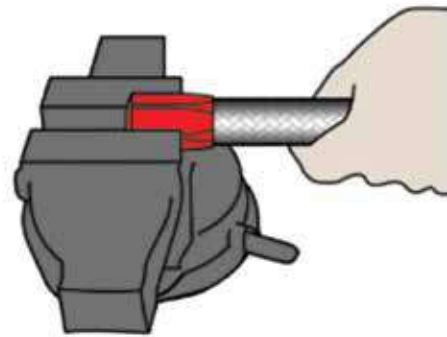

2. Holding the socket nut in the fitting soft jaws, remove the tape and proceed to push it into the nut while twisting the hose. This is a tight fit due to the design of the fitting. We recommend the use of the Proflow installations tool to make this job easier.



3. Once the hose is all the way in, use a marker to mark a line where the socket nut finishes.

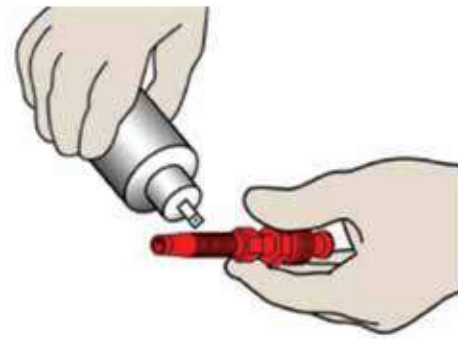

4. Lubricate the inside of the hose and the outside of nipple including the threads.

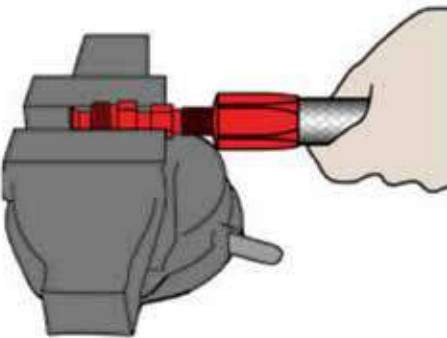

5. Push the socket nut on to the nipple thread.

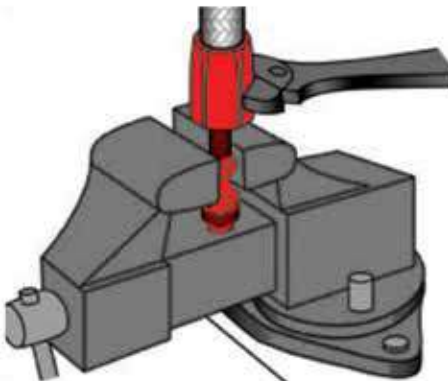

6. Proceed to tighten until the fitting has gap no larger than your nail. Make sure the mark on the hose has not moved back from the end of the socket nut. The hose is now ready to use. Use compressed air to remove any foreign objects from the lines.

200 Series Hose

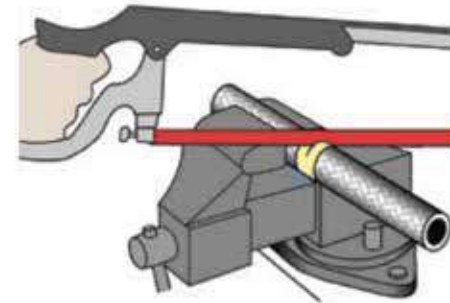

1. Wrap masking or electrical tape around stainless braided hose to stop fraying. Then cut hose square with a fine cut off wheel or fine hacksaw.

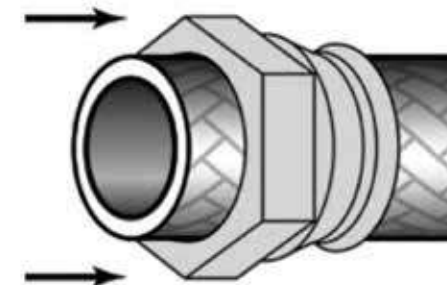

2. Place the socket nut over the Teflon hose and move down 150 mm.

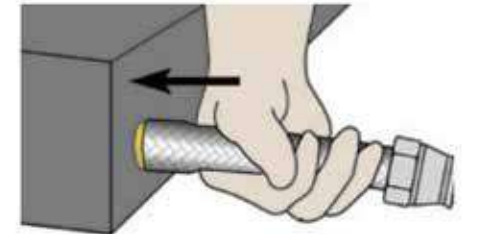

3. Push the olive onto the Teflon using an olive tool or using the bench face allowing the braid to move over the top of the olive.

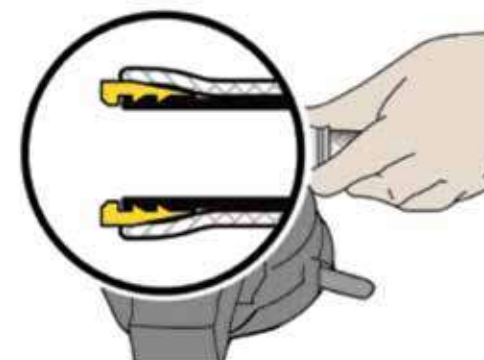

4. Check that the olive has seated correctly.

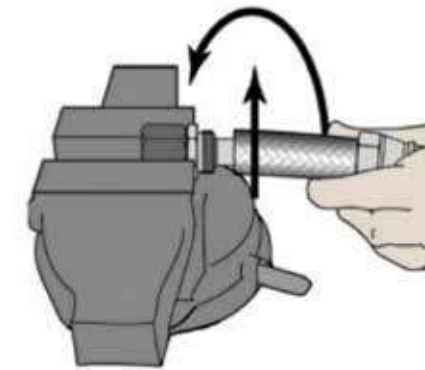

5. Use a small amount of lubricant and push the olive over the shank of the fitting. Twisting and pushing until the thread starts on the fitting.

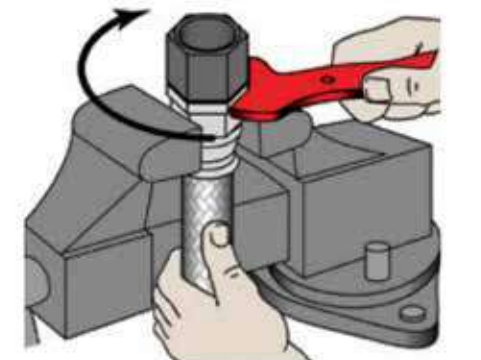

6. Proceed to tighten until the fitting has gap no larger than your nail. The hose is now ready to use. Use compressed air to remove any foreign objects from the lines. When reusing these fittings, it will require a new olive. These are available as a spare part.

Assembly

Push Lock Hose Ends

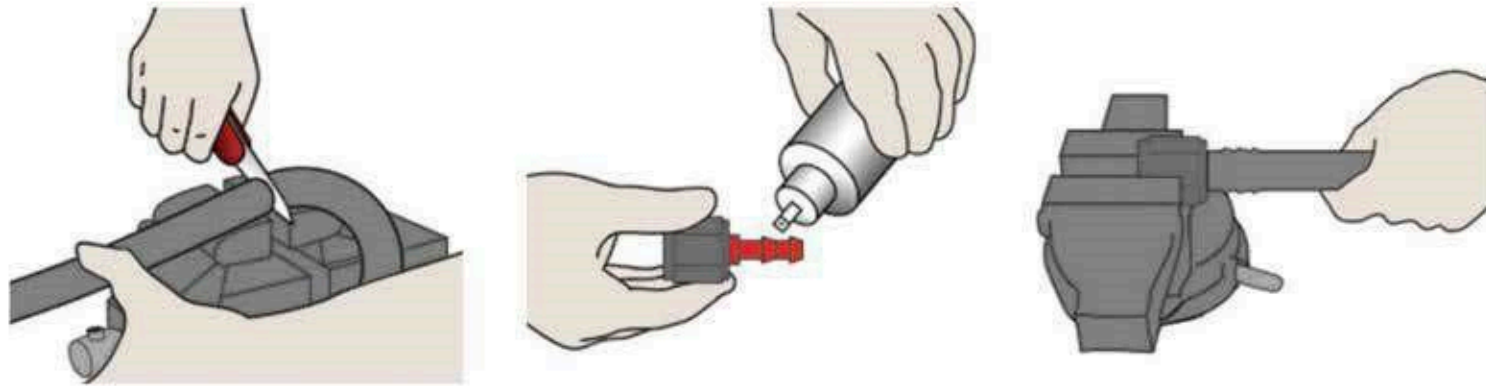

1. Cut the rubber hose to the correct length making sure the end is square.
2. Lubricate the barb with a suitable lubricant.
3. Push the hose onto the barb until it slides home under the collar.

Installation Tool

The Speedmaster™ installation kit is the only one on the market that actually installs the stainless hose into the socket nut with out the need to push or have your hands damaged by the stainless over-braid. This unit will work on Speedmaster™'s stainless steel braided hose -4 to -12 in size, but can be used for other applications. Due to the tight tolerances of the stainless braid and the size of the socket nut, it is usually quite difficult to install the socket nut. Traditionally most people use a vise for this job. With the Speedmaster™ installation tool this is not an issue. The tool can be used in 2 configurations, to install the stainless hose into the socket nut and also as a fitting vice to assemble the fitting. There is no more pushing and pulling at the hose in a vise. The tool is easy to use and the different components slide on and off the base. A ball bearing is used to locate each component in the correct position.



1. To use the tool just unscrew the thumb screws to release the hose clamp assembly. The socket nut holder slides open to place the correct size holder as well as the socket nut.
2. Slide the cover back and slide the socket nut insert into the tool and slide the hose clamp inserts into the holder.
3. Place the socket nut into the tool holder and place the hose into the hose clamp. Put the nut into the nut clamping mechanism and then slip the cover of nut clamping mechanism into position. Place the stainless steel braided hose into hose clamping mechanism and tighten the two hold down screws.



4. Once the cover is closed and the hose is clamped proceed to twist the handwheel continuously until it cannot rotate any further.
5. Remove the covers and clamp and remove the hose with the socket nut now installed on the hose.
6. To assemble the rest of the components slide the hose clamp and handwheel assembly off the base.

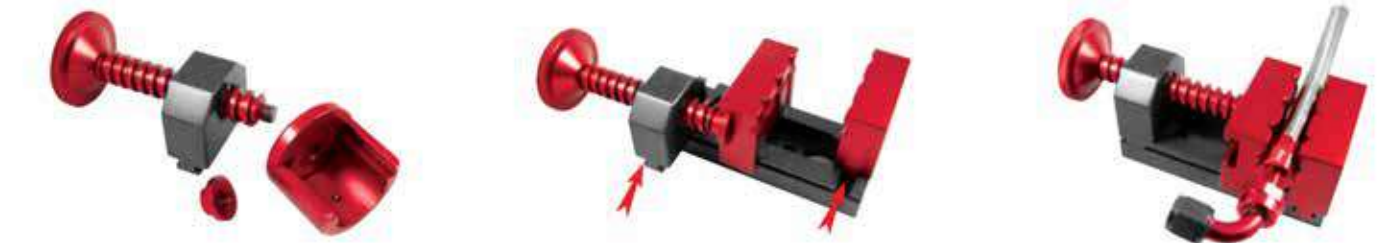

7. Now unscrew the socket nut holder and screw on the vice adaptor.
8. Slide both sections of the vice jaws on to the base of the assembly. Place the vice adaptor into the end of the vice jaws and then slide the handwheel assembly on to the base.
9. The unit is now complete and can hold any style of fitting ready to tighten with an alloy spanner without any damage.



WORLD



FASTEST
DOOR CAR



SPEEDMASTER™
EST. 1979

MORAN Atomizer Injectors

FUCHS The Lubricant Specialists
GERMAN TECHNOLOGY
www.fuchs.com.au





Traction Drive Systems

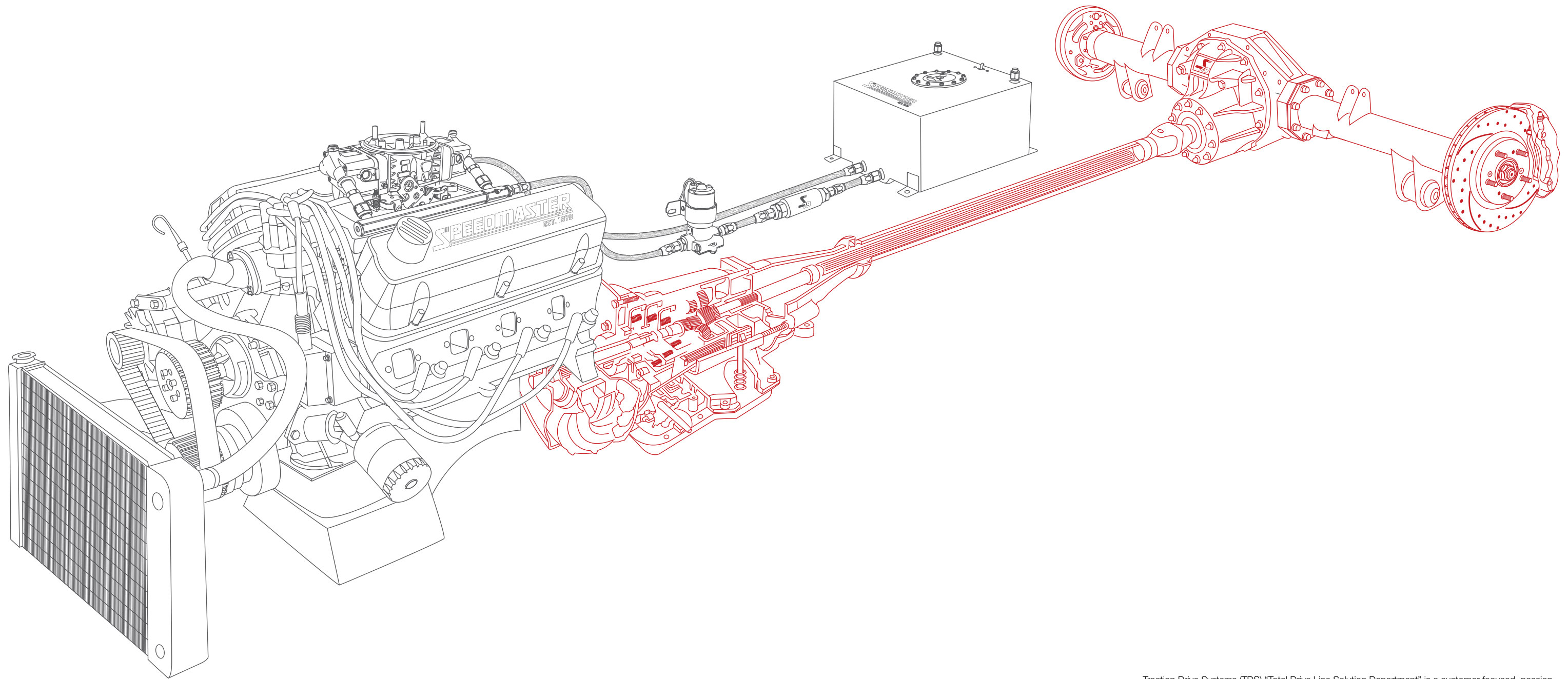

Traction Drive Systems (TDS) "Total Drive Line Solution Department" is a customer focused, passion driven department; with its sole aim being to solve all customers traction needs and wants. Our department utilizes both technical & Design knowledge, which has been attained over 40 years experience in the differential repair industry. The TDS mission has been cemented from years of constant commitment to the research and development by the founder of 'Ron's Signature Series' by Ron Smelt.

Axle Assemblies

Eager for Action

Can your axle assembly survive the high-torque, high-power output of your modified street/strip engine? Or how about the harsh, unforgiving terrain of your next off-road excursion? Make sure the answer is yes by replacing your stock or broken axle assembly with something better from Speedmaster. Broken axles equal broken dreams—avoid the nightmare with complete axle assemblies from Speedmaster™.



Assembly:

Assembly has been carried out at the Speedmaster's TDS Department by the Head differential technician. Quality is assured with 40 years experience in the Differential Industry and full involvement in all forms of motorsport from V8 SUPERCAR To Group 1 Drag Racing. Our Technician is on hand to discuss your differential requirements, questions and upgrades.



Maximum strength



Withstand extreme use



Avoid long term distortions



Superior wear resistance



Faster reaction



Eliminates gear failure

28-Spline Superstreet Series

Speedmaster™ Ford 9 inch 28-Spline Modular Differential Complete is perfect for mildly built street cars.



31-Spline Outlaw Series

Speedmaster™ Ford 9 inch 31-Spline Modular Differential Complete is perfect for high performance street cars up to 700 horsepower, or as an upgrade from 28-Spline.

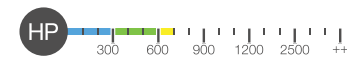

35-Spline Sportsman Series

Ken's Signature Series

For absolutely serious street and racing applications, Ford 9 inch 35-Spline Modular Differential Complete. Parts available for this unit are 1200 HP rated.

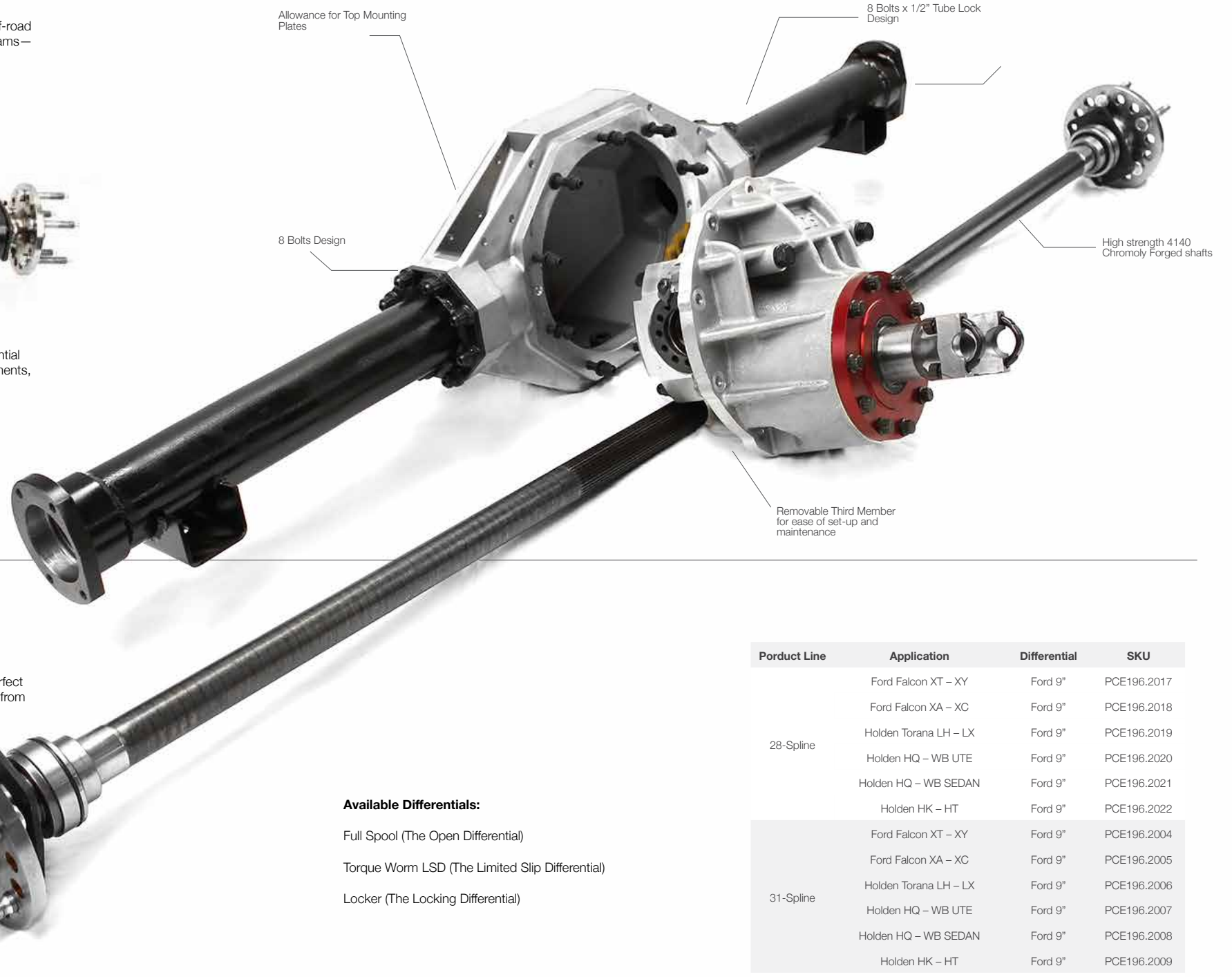
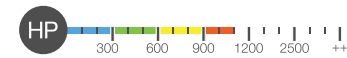

Available Differentials:

- Full Spool (The Open Differential)
- Torque Worm LSD (The Limited Slip Differential)
- Locker (The Locking Differential)

Product Line	Application	Differential	SKU
28-Spline	Ford Falcon XT – XY	Ford 9"	PCE196.2017
	Ford Falcon XA – XC	Ford 9"	PCE196.2018
	Holden Torana LH – LX	Ford 9"	PCE196.2019
	Holden HQ – WB UTE	Ford 9"	PCE196.2020
	Holden HQ – WB SEDAN	Ford 9"	PCE196.2021
	Holden HK – HT	Ford 9"	PCE196.2022
31-Spline	Ford Falcon XT – XY	Ford 9"	PCE196.2004
	Ford Falcon XA – XC	Ford 9"	PCE196.2005
	Holden Torana LH – LX	Ford 9"	PCE196.2006
	Holden HQ – WB UTE	Ford 9"	PCE196.2007
	Holden HQ – WB SEDAN	Ford 9"	PCE196.2008
	Holden HK – HT	Ford 9"	PCE196.2009
35-Spline	Ford Falcon XT – XY	Ford 9"	PCE196.2011
	Ford Falcon XA – XC	Ford 9"	PCE196.2012
	Holden Torana LH – LX	Ford 9"	PCE196.2013
	Holden HQ – WB UTE	Ford 9"	PCE196.2014
	Holden HQ – WB SEDAN	Ford 9"	PCE196.2015
	Holden HK – HT	Ford 9"	PCE196.2016

Rear Axle Housings

Innovative Performance

"STRONG AND VERSATILE" - That's what makes the 9 inch Ford diff so popular. Most people running performance street vehicles have had the misfortune to break either axles or a center and once you start combining high horse power with big tires, the inevitable occurs. The added stress is usually too much for the stock rear axle assembly. However Speedmaster™ is here to solve the problem, Speedmaster's Axle Housings combine brute strength and light weight with the added benefit of a removable third member for ease of set-up and maintenance.

PCE224.1001 Ford 9" | Modular Differential Housing Section & Tubes CTL Combo

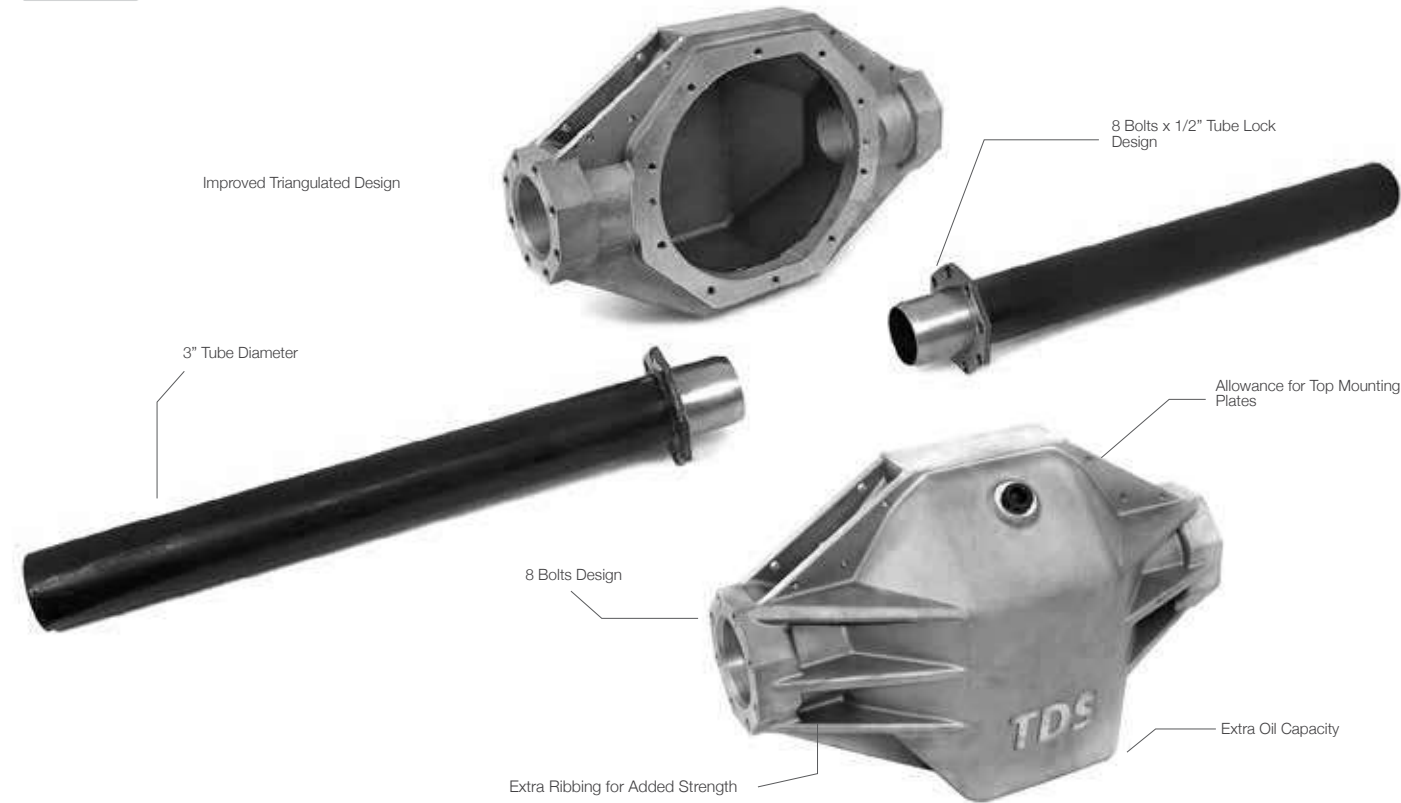

Axle Housing Top Plates

Add even more strength to your Speedmaster™ housing with these top mounting plates from Speedmaster™.



PCE197.1001 Ford 9" Rear Modular Differential Housing top plates

Axle Housing Ends

Whether narrowing a rear axle housing for bigger tires or just building a new housing for your street car, you will need housing ends to complete the project. The rear housing ends are made of billet steel and CAD-designed to ensure a proper fit.



Flange Type	Size	SKU
Small Ford	65mm	PCE198.1001
	72mm	PCE198.1002
Large Ford	80mm	PCE198.1003
	Torino	80mm
BA Ford	65mm	PCE198.1005
	72mm	PCE198.1006
Holden	65mm	PCE198.1007
	72mm	PCE198.1008

Axle Shafts

When Quality is the Aim



Speedmaster™ axles are produced using state of the art equipment and manufacturing techniques. We constantly strive to improve the processes and we stand behind the quality of Speedmaster™ axle shafts. These forged steel street axles are non-tapered with hardened bearing seats and machined to fit a variety of applications. These axles are available in any length up to 34 inch and if you choose to narrow your rear-end at a later time, these axles can be shortened to suit.

Product Benefits

- High strength 4140 Chromoly Forged shafts, 4140 Chromoly provides approximately 27 percent more strength than standard Axle steel of 1040.
- Speedmaster™ axles are Induction Harden to RC 56-60.
- Trim to desired length.
- Eliminates the cost and need for custom Axles!

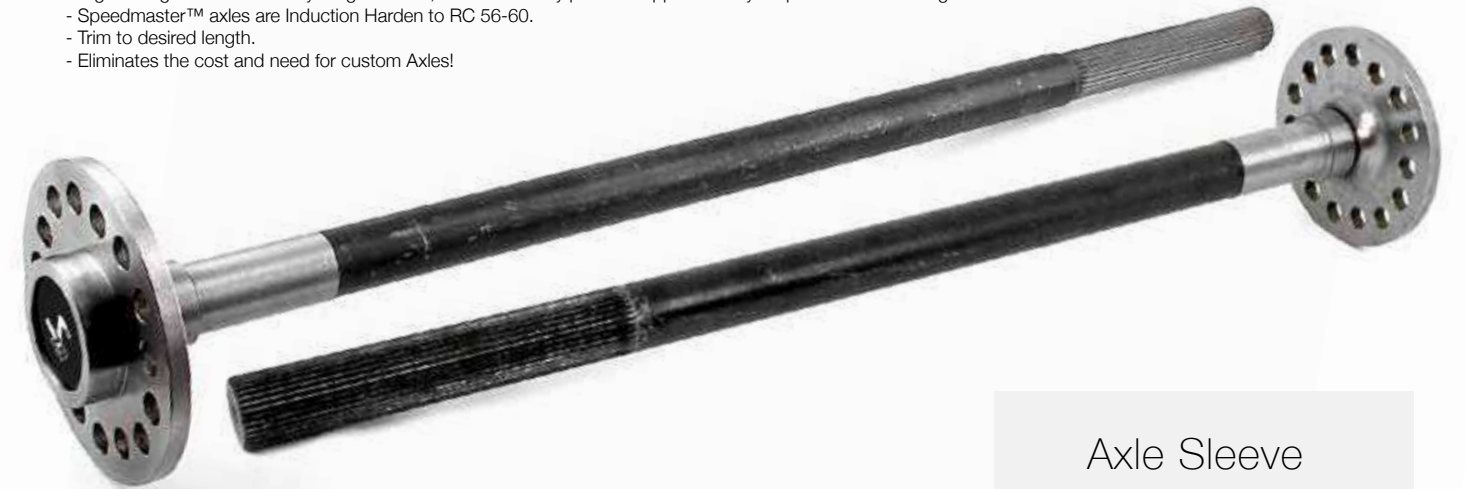

Inner Axle Splines	Axle Type	Wheel Stud Type	Wheel Stud Pattern	Axle Length (in)	SKU
28	Flanged	Press-in	4.500 in. 4.750 in. 120mm	30.000 in.	PCE201.1002
				34.000 in.	PCE201.1003
31	Flanged	Press-in	4.500 in. 4.750 in. 120mm	30.000 in.	PCE201.1005
				34.000 in.	PCE201.1006
35	Flanged	Press-in	4.500 in. 4.750 in. 120mm	30.000 in.	PCE201.1008
				34.000 in.	PCE201.1009

Axle Sleeve



Type	SKU
Small	PCE420.1007
Large	PCE420.1008

More

Axle Retainer Plates

Axle retainer plates are designed to be mounted solidly to the axle housing end, to keep your rear axle in place and are laser cut to ensure perfect fitment.



Flange Type	SKU
Small Ford	PCE200.1001
Large Ford	PCE200.1002
Torino	PCE200.1003
BA Ford	PCE200.1004
Holden	PCE200.1005

Wheel Studs

Speedmaster™ press-in wheel studs are constructed from heat-treated alloy steel with a tensile and shear strength that exceeds SAE Grade 8 specs by 25 percent. These wheel studs feature durable finish and fatigue-resistant rolled threads.



Thread Size	Knurl Diameter (in.)	Underhead Length (in)	Quick-Start Nose	SKU
1/2 in. UNF	0.610 in.	2.000 in.	No	PCE408.1002
		2.500 in.	Yes	PCE408.1001
		3.000 in.	No	PCE408.1006
5/8 in. UNF	0.640 in.	2.000 in.	Yes	PCE408.1005
7/16 in. UNF	0.600 in.	3.000 in.	No	PCE408.1003
		3.000 in.	No	PCE408.1004

Third Members

State of the Art

The aluminum available today is vastly different from that of years past. Technology has made aluminum products stronger and more durable. Knowing this, the Speedmaster™ engineers decided to have an aluminum Ford 9" dropout case built. You may say to yourself, "That's nothing new, other companies have been making them for years," and that's true; but as in every Speedmaster™ product, we look closely at what's out in the marketplace and how it can be improved. Our aluminum cases are made from A356-T6 aluminum, our bearing caps are one-piece billet, with a through bolt design and extra material is added to the bearing caps and extended nose design allows for reduced pinion deflection which extends bearing and gear life. This results in 50% less deflection that can occur with other units on the market. These cases are offered in 3.250" bearing diameter to accommodate 28, 31 and 35-spline carriers and spools. These extras truly make this Aluminum case the ultimate Ford 9" case, rated to 1200 horse power. All Speedmaster™ Extended Nose Aluminum third members come with 12 point through bolts and a Daytona style pinion support, which gives us an advantage over our competition.



Billet Steel Yoke
Maximum strength



Daytona Pinion Support
Withstand extreme use
(31 & 35 Spline only)



Aluminum Case
Avoid long term distortions



8620 Gear Set
Superior wear resistance



6 Pinion Gear Unit
Faster reaction



Lightweight Full Spool
Eliminates gear failure



Assembly:

Assembly has been carried out at the Speedmaster's TDS Department by the Head differential technician. Quality is assured with 40 years experience in the Differential Industry and full involvement in all forms of motorsport from V8 SUPERCAR To Group 1 Drag Racing. Our Technician is on hand to discuss your differential requirements, questions and upgrades.



28-Spline Superstreet Series

Speedmaster™ Ford 9 inch 28-Spline diff center is perfect for mildly built street cars or just to replace stock diff centers.

- Dropout:** 1310 Series
- Carrier:** Full Spool or Torque Worm LSD
- Case:** Standard HD Aluminum Dropout
- Pinion Support:** Oversize

**Rated at 850HP, Limited to 350HP due to Factory 28 spline Axles.



31-Spline Outlaw Series

Speedmaster™ Ford 9 inch 31-Spline diff center is perfect for high performance street cars up to 700 horsepower, or as an upgrade from 28-Spline.

- Dropout:** 1350 Series
- Carrier:** Torque Worm LSD
- Case:** Long Nose HD Aluminum Dropout
- Pinion Support:** Daytona Style

**Rated at 850HP, Limited to 700HP due to Factory 31 spline Axles.



35-Spline Sportsman Series *Ren's Signature Series*

For absolutely serious street and racing applications, Ford 9 inch 35-Spline diff center. Parts available for this unit are 1200 HP.

- Dropout:** 1350 Series
- Carrier:** Torque Worm LSD
- Case:** Long Nose HD Aluminum Dropout
- Pinion Support:** Daytona Style

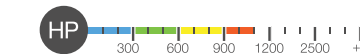

Calculate Rear End Gear Ratio Needed

Case Style	Splines	Case	Carrier Type	Yoke Style	Ring and Pinion Ratio	Item No.
Ford 9"	28	Standard HD Aluminum Dropout	Torque Worm LSD	1310 Series	3.00:1	PCE215.2036
					3.25:1	PCE215.2038
					3.50:1	PCE215.2040
					3.70:1	PCE215.2042
					3.90:1	PCE215.2044
Ford 9"	31	Standard HD Aluminum Dropout	Torque Worm LSD	1350 Series	4.11:1	PCE215.2046
					3.25:1	PCE215.2048
					3.50:1	PCE215.2049
					3.70:1	PCE215.2050
					3.90:1	PCE215.2051
Ford 9"	35	Long Nose HD Aluminum Dropout	Torque Worm LSD	1350 Series	4.11:1	PCE215.2052
					4.56:1	PCE215.2053
					3.25:1	PCE215.2004
					3.50:1	PCE215.2005
					3.70:1	PCE215.2030
Ford 9"	35	Long Nose HD Aluminum Dropout	Torque Worm LSD	1350 Series	3.90:1	PCE215.2031
					4.11:1	PCE215.2032
					4.56:1	PCE215.2033

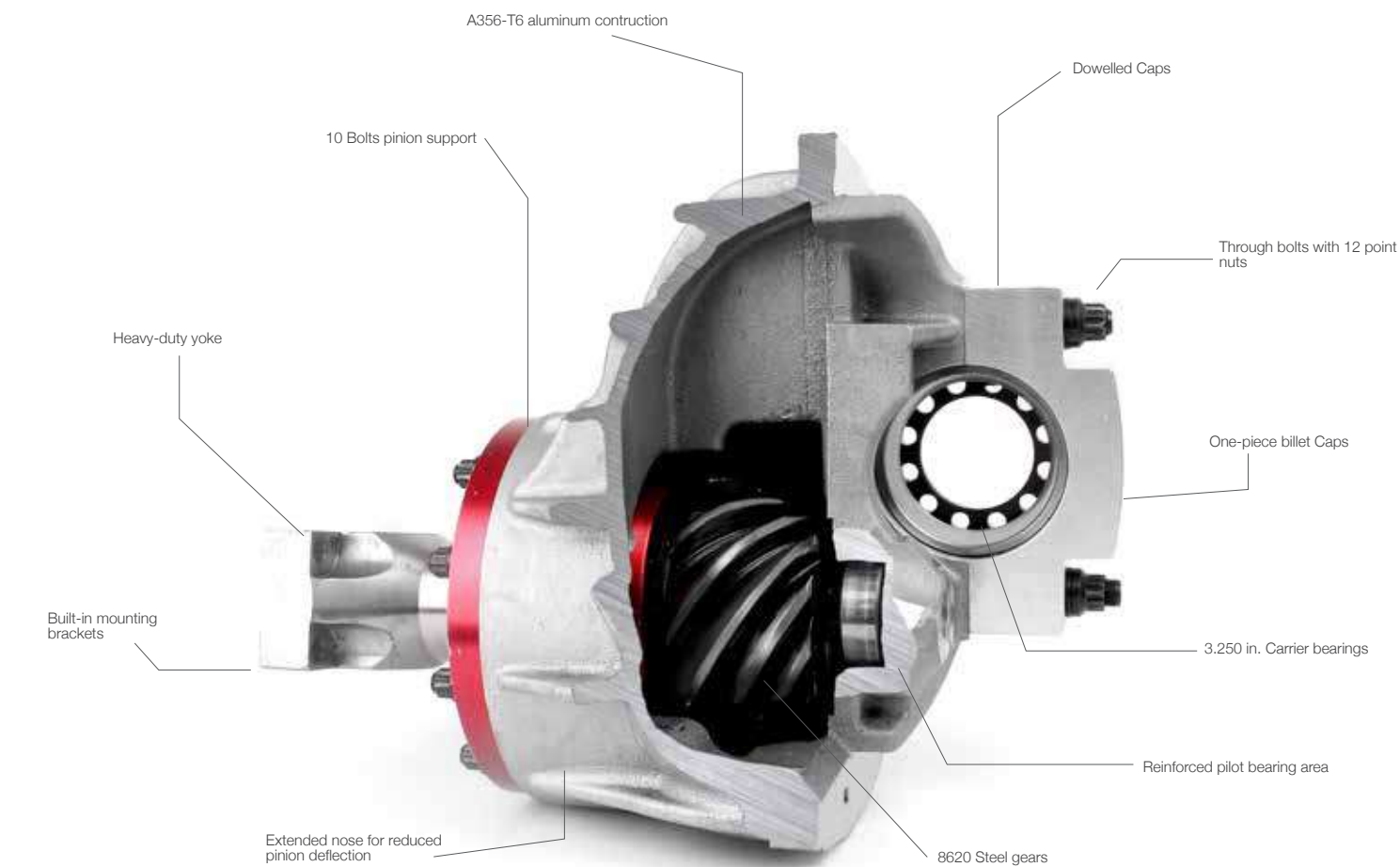

Speedmaster™ Product Development

Automotive, Industrial, Mechanical & Concept Design

Using modern simulation tools, "virtual products" are created, enabling the functionality of a product to be analysed prior to prototyping and pre-production of hard parts, minimizing the number of design iterations. Both CAD data and detailed engineering drawings are used for manufacturing and validation.

- Capable of translating all major software formats.
- 3D scanning with reverse engineering.
- Complete engineering drawings.
- Modeling in ptc pro engineer.
- Project management.
- Appq, fmea

Digital data can be translated from any of the major software formats being used around the world.

- Unigraphics, ideas
- Iges, step

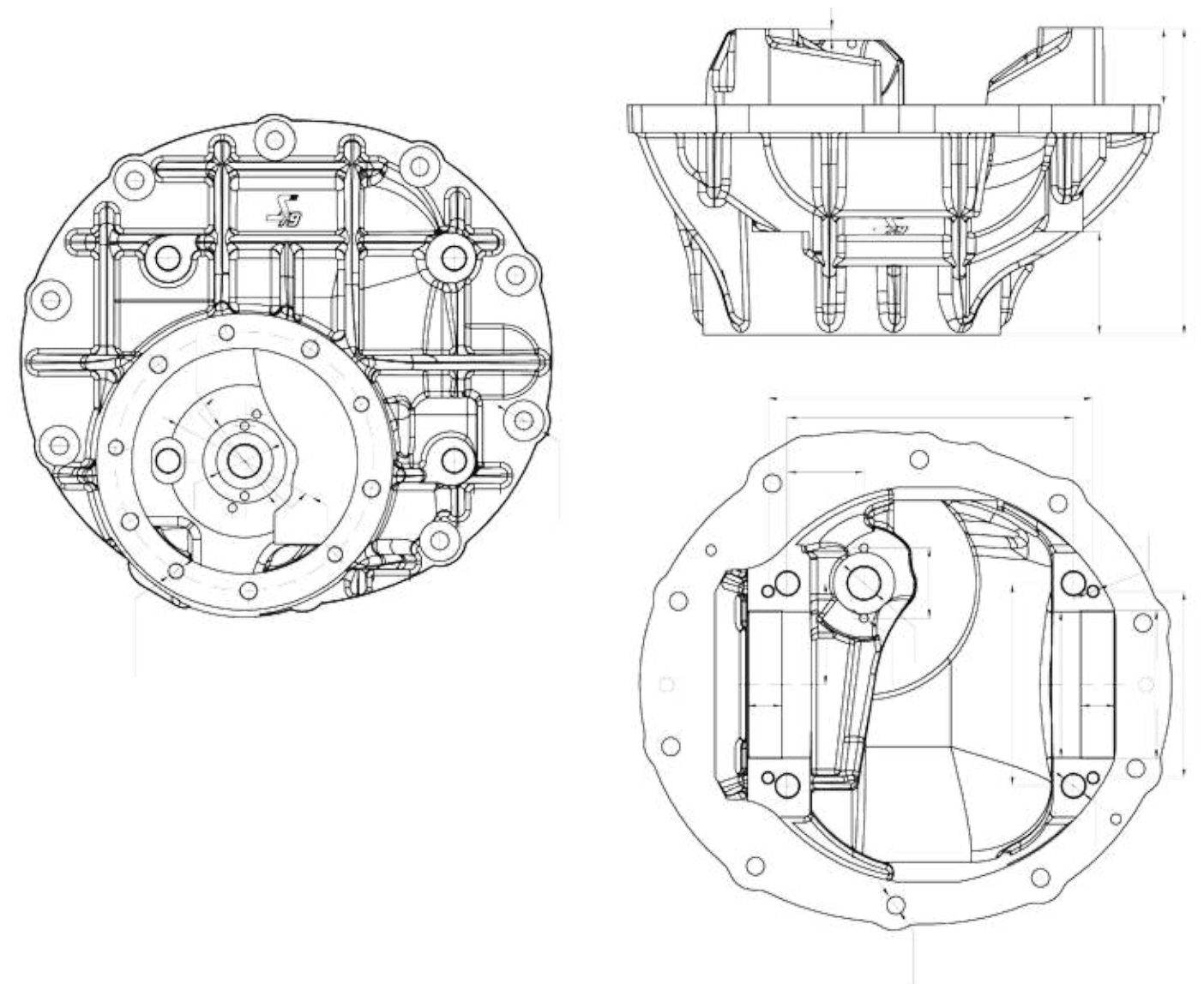

Third Member Case

HD Dropouts

Aluminum Dropouts are in improvement from the past. Current technology has made aluminum products stronger and more durable. Our aluminum cases are made from 356 T6 aluminum, our bearing caps are from one-piece billet, with a through bolt design and extra material is added to the bearing caps. This results in 50% less deflection that can occur with other units on the market.

a STD Nose



b Long Nose



Ref.	Case Style	Case Material	Main Caps Included	Main Cap Material	Main Cap Retention Style	Carrier Bearing Diameter (in)	Pinion Support Bolt Quantity	Pinion Location	Pinion Support Included	Hardware Included	SKU
a.	Ford 9"	Aluminum	Yes	7075-T6 Billet Aluminum	Thru Bolt	3.250 in.	10	Standard	No	Yes	PCE214.1004
b.	Ford 9"	Aluminum	Yes	7075-T6 Billet Aluminum	Thru Bolt	3.250 in.	10	Extended 0.750 in.	Yes (Daytona Style)	Yes	PCE214.1005

Third Member Components

Pinion Supports

Speedmaster™ aluminum pinion supports are completely CNC machined from our designed forgings or billet 6061-T6. They are an economical solution to replacing failure-prone stock supports. Speedmaster™ pinion supports are designed to withstand extreme use.



Pinion Support Bolt Quantity	Style	Bearing Cups Installed	Pinion Support Material	Pinion Support Finish	SKU
5	Daytona	No	6061 T6 Aluminum	Red anodized	PCE209.1001
5	Oversize	No	6061 T6 Aluminum	Red anodized	PCE209.1003

Yokes

When building rear-ends for race cars or trucks, people tend to forget that the yoke is the one piece that ties it all together. They just reuse the old, beat-up OEM cast iron yoke. A billet yoke can mean the difference between winning and losing. Understanding that being first across the line is what it's all about; TDS stepped up and created a full line of super-strong forged and billet yokes. These yokes offer maximum strength for high horsepower cars as well as a sleek look for that show finish.

Axle Model	Yoke Inner Spline Quantity	Yoke Material	Universal Joint Style	Yoke Overall Length (in)	SKU
Ford 9 in.	28	Steel	1310 Series	4.750 in. (120mm)	PCE216.1001
	28	Steel	1350 Series	4.750 in. (120mm)	PCE216.1002
	28	Steel	1350 Series	3.750 in. (92mm)	PCE216.1003
	35	Steel	1350 Series	3.750 in. (92mm)	PCE216.1004



U-Joint Fasteners

Speedmaster™ u-joint have a unique design which provides more bearing surface for the universal joint bearing cap. The result is greater strength compared to conventional girdles.



Ref.	U-Joint Type	Universal Joint Style	Material	Finish	SKU
a.	U-Bolts	1310 Series	4140 Steel	Silver	PCE433.1001
b.	U-Bolts	1350 Series	4140 Steel	Black	PCE433.1002
c.	Girdles	1350 Series	Aluminum	Blue Anodized	PCE433.1003

Differential Carriers

This is the new level

Torque Worm LSD

Maintenance-free

The Torque Worm is a torque biasing 6 pinion gear type limited slip unit. This is a preloaded unit allowing for a faster reacting unit. Unlike our competitors that only use 3 or 4 pinion gears. The use of 6 pinion gears means the stress on gears is spread over a greater surface area, reducing the load on all internal components.



The internal components are made from EN36 Material as used in racing such as V8 SUPERCAR. The outer cases made from 8620 Chrome-Nickel-Moly steel and the case hardened for long life and improved strength. The Torque Worm unit is available in 28, 31 and 35 spline counts.

Locker

The purpose of the Locker is to maximize traction by delivering 100 percent of the torque and power to both drive wheels. They are engineered to keep both wheels in a constant drive mode and have the ability to automatically allow wheel speed differentiation when required to ease cornering at low speeds.



Aftermarket Carrier Style	Axle Model	Axle Shaft Spline Quantity	Carrier Material	SKU
Torque Worm LSD (Limited slip)	Ford 9 in.	28	Steel	PCE204.1001
	Ford 9 in.	31	Steel	PCE204.1002
	Ford 9 in.	35	Steel	PCE204.1003
	Ford 9 in. Gen II	35	Steel	PCE204.1013
	Ford 8.8 in.	31	Steel	PCE204.1012
	80 Series Borg/W	28	Steel	PCE204.1004
	80 Series Borg/W	31	Steel	PCE204.1005
	Dana M86	30	Steel	PCE204.1006
	ZF	32	Steel	PCE204.1007
Locker	GM 8.6 in.	32	Steel	PCE204.1008
	Ford 9 in.	28	Steel	PCE204.1009
	Ford 9 in.	31	Steel	PCE204.1010
	Ford 9 in.	35	Steel	PCE204.1011

Quick Tip



How to Choose the Appropriate Differential

Your differential transmits the power to the axle shafts while allowing the wheels to rotate at different speeds, since they travel different paths as a vehicle turns. The standard open differential works great for this application, but has its shortcomings when it comes to off road and performance driving. To remedy this, there are different options such as limited slip differentials, lockers & spools. They each have their advantages for different driving conditions. The following guide will help you decide which kind of differential works best for your driving needs.

Limited Slip

Distribute power to the axle with the most traction; Suitable for daily driving on pavement.



Lockers

Locked both axles but allows the tires to rotate at different speeds around corners; Great for extreme off road use.

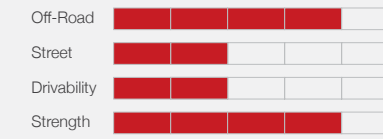

Spools

Open differential with the strength & traction of a spool; Controlled by the driver.

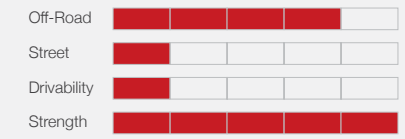

Spools

Spools are actually the lack of a differential. Spools are a 100% lock-up between both wheels of an axle all the time. Spools are generally used for racing and serious offroad use where little or no street driving is seen by the vehicle and a stronger, lighter rear end is needed. The mini spool uses the stock carrier replacing only the internal components of the differential and a full spool replaces the entire carrier assembly with a single machined piece.

Mini Spools

Machined on state-of-the-art CNC machines from chromoly steel, these mini spools will take racing abuse. They replace the side and spider gears in your factory open differential carrier and lock your axles together for positive traction.



Axle Model	Cover Bolts	Axle Shaft Spline Quantity	Spool Material	SKU
Ford 9 in.	10	28	Steel	PCE213.1001
	10	31	Steel	PCE213.1002

Full Spools

The TDS lightweight spools give you the traction you need by locking the axle shafts together, forcing your rear tires to turn at the same speed. They're CNC-machined from forged chromoly steel to provide a more rigid ring gear mounting. This eliminates gear failure caused by case deflection or differential side-gear failure.



Axle Model	Cover Bolts	Axle Shaft Spline Quantity	Spool Material	SKU
Ford 9 in.	10	28	Steel	PCE213.1005
	10	31	Steel	PCE213.1006
	10	35	Steel	PCE213.1007

Ring and Pinion Gears

Ready for the Harshest Conditions



Ring and pinion gears are the automotive hardware that rotates the wheels of a car backwards and forwards; they work in conjunction with the drive shaft to create torque for the drive wheels. The pinion and drive shaft are attached and therefore must spin together to generate enough torque that in turn creates the power that moves the wheels forward.

These Speedmaster™ ring and pinion sets are engineered, manufactured and tested for maximum performance. These ring and pinion sets are CNC-cut from 8620 steel for outstanding durability, factory-lapped for a precise fit, and Rockwell-tested for hardness. Available in many different ratios to fit a variety of differentials.



Axle Model	Cover Bolts	Ring Gear Bolts	Pinion Spline Count	Ring Gear Rotation	Ring Gear Diameter (in)	Pinion Shaft Diameter (in)	Ring and Pinion Ratio	Ring Gear Teeth	Pinion Gear Teeth	SKU
Ford 9 in.	10	10	28	STD	9.000 in.	1.313 in.	3.00:1	39	13	PCE211.1034
	10	10	28	STD	9.000 in.	1.313 in.	3.25:1	39	12	PCE211.1001
	10	10	28	STD	9.000 in.	1.313 in.	3.50:1	35	10	PCE211.1002
	10	10	28	STD	9.000 in.	1.313 in.	3.70:1	37	10	PCE211.1003
	10	10	28	STD	9.000 in.	1.313 in.	3.89:1	35	9	PCE211.1004
	10	10	28	STD	9.000 in.	1.313 in.	4.11:1	37	9	PCE211.1005
	10	10	28	STD	9.000 in.	1.313 in.	4.56:1	41	9	PCE211.1006
	10	10	28	STD	9.000 in.	1.313 in.	4.88:1	34	7	PCE211.1007
10	10	28	STD	9.000 in.	1.313 in.	5.14:1	36	7	PCE211.1008	

Ring Gear Fasteners









Speedmaster™ ring gear bolt kits are forged from premium-grade 8740 chromoly steel and heat-treated to a rating of 190,000 psi.



PCE212.1002 Ford, 9 in. Chromoly, Black Oxide Set of 10

What Gears Can Do for You

Avoid losing power & gas mileage when adding larger tires. The diagram below shows the impact of installing larger tires and changing the overall drive ratio on your vehicle. This diagram is based on 65 MPH and a 1:1 gear ratio on a manual transmission (4th gear). Please NOTE: RPM in overdrive will vary on vehicles equipped with an automatic or an overdrive transmission.

Tire Size	Gear Ratio	5th Gear	Engine RPM	Results
Before Changing Gears  35" Tall	 3.55	 SPEED 65	 RPM	Lacks performance and reduces fuel economy
After Changing Gears  35" Tall	 4.56	 SPEED 65	 RPM	Returns power band to factory settings

Checking Distance

Each ring and pinion is pre-run and marked on the pinion face with its proper depth setting called the "Checking Distance". This dimension is from the face of the pinion to the axle center-line. A setting tool must be used to measure the checking distance. Pinion depth is adjusted by adding or subtracting shim distance. Stay +/- .002" of the pinion dimension (see Illustrations).

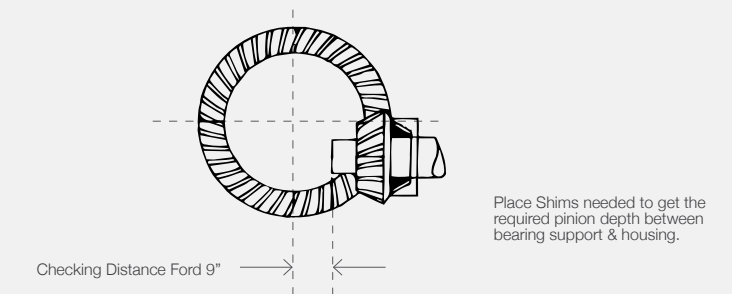

Ring Gear Spacers

If you're installing to a 75 Series BTR unit this kit is required, when using a 80 Series Carrier, the spacers will provide proper backlash and offer a secure mount for your ring gear. Longer ring gear bolts are included.



PCE479.1001 B/W M80 to M75 & Bolts

Differential & Rear-End Components

Differential Carrier Bearings

When changing your ring and pinion set, don't forget these Speedmaster™ carrier bearings. Made of top-notch materials, these bearings are made with all of the quality that Speedmaster™ is known for. These bearings have tapered inner and outer raceways between which tapered roller are arranged. The design of taper rollers makes them particularly suited to accommodating combined axial and radial loads. They are supplied as a cup and cone set (inner and outer).



Inside Diameter	Outside Diameter	Width	Industry STD Reference	SKU
45.24mm 1.7812 in	73.43mm 2.891 in	19.56mm 0.77 inch	LM102949/910	PCE203.1001
45.24mm 1.7812 in	77.79mm 3.0625 in	19.84mm 0.7812 inch	LM603049/011	PCE203.1002
50.80mm 2 in	82.55mm 3.25 in	21.59mm 0.85 inch	LM104949/911	PCE203.1003
-	-	-	LM603049	PCE203.1004

Axle Bearings

Precision-machined and constructed from the highest quality materials, these Speedmaster™ axle bearings provide outstanding and long-lasting performance. Offered in a wide variety of sizes and styles, Speedmaster™ axle bearings are sure to meet any bearing needs you may have.

Industry STD Reference	SKU
SET 10 (U399/U360L) + SEAL (73.10MM X 1.562") T/R	PCE231.1001
(U261L/U298) + SEAL (65MM X 35MM) T/R	PCE231.1002
RW207 + SEAL (72MM X 35MM)	PCE231.1003
RW507ER + SEAL (72MM X 35MM)	PCE231.1004
RW9022834 + SEAL (72MM X 1.562")	PCE231.1005
SET 20 (80MM X 1.562") T/R	PCE231.1006
38.50MM CUSTOM	PCE231.1007
39.65MM (A1021)	PCE231.1008
35MM (A1021)	PCE231.1009



Pinion Bearings

Speedmaster™ pinion bearings offer durability and peace of mind. Known the world over, Speedmaster™ bearings are precision-engineered to provide you with quality, energy-efficient, and cost-effective friction management. For a proper fit that will run smoothly, these single-row tapered roller bearings are your best bet to replace old and worn pinion bearings.



Inside Diameter	Outside Diameter	Width	Industry STD Reference	SKU
33.34mm 1.3125 inch	68.26mm 2.6875 inch	22.23mm 0.875 inch	M88048/010	PCE207.1005
33.34mm 1.3125 inch	76.20mm 3 inch	29.37mm 1.1563 inch	HM89443/410	PCE207.1006
33.34mm 1.3125 inch	76.20mm 3 inch	23.81mm 0.9375 inch	2790/2729	PCE207.1007
38.10mm 1.5 inch	76.20mm 3 inch	23.81mm 0.9375 inch	2788/2729	PCE207.1008
47.63mm 1.875 inch	95.25mm 3.75 inch	30.16mm 1.1875 inch	HM804846/810	PCE207.1009

Pinion Seals

Speedmaster™ offers pinion seals separately for those of you who ran out or just plain need some. They are designed for most axle models. They feature steel construction and inner rubber with a spring to create the leak-free seal.



Industry STD Reference	SKU
1.812 x 3.000 X 0.375 (STD 9")	PCE416.1001
2.125 x 3.000 X 0.375 (OS 9")	PCE416.1002
2.000 x 3.000 X 0.375 (OS 9" 1350)	PCE416.1003

Pilot Bearings & Circlip

Speedmaster™ roller pilot bearings are direct replacements. When you install a new clutch, just pick up one of these to obtain less friction and longer life out of your clutch assembly.



Industry STD Reference	SKU
R1535TAV	PCE468.1001
Pilot Bearing Circlip	PCE468.1002

Chassis Components

Chassis Brackets

Speedmaster™ has designed all new replacement bracketry for the HQ-WB Holden, Torana LH-LX, Torana LC-LJ as well as the universal leaf spring housing mounting pads.



Suspension Lift Components & Kits

Speedmaster™ suspension lift kit components will finish off your suspension lift kit. They include all of the necessary parts to make installation a breeze.



- | | | |
|--|---|--|
| a. PCE443.1008 Holden HQ HJ HX HZ WB Kit | e. PCE170.1001 U-Bolt 10" Length Square
PCE170.1003 12.5" Length | h. PCE170.1005 2" Aluminum Block w/ U-Bolts & Hardware
PCE170.1006 3"
PCE170.1007 4" |
| b. PCE443.1009 Holden LH LX Kit | f. PCE170.1002 U-Bolt 10.5" Length Round
PCE170.1004 13" Length | |
| c. PCE443.1010 Holden LC LJ Kit | g. PCE181.1001 1" Cast iron Block
PCE181.1002 2"
PCE181.1003 3"
PCE181.1006 4" | |
| d. PCE443.1011 Holden HQ - WB 3" Diameter Axle Pair
PCE443.1012 Ford Falcon
PCE443.1013 Ford Mustang | | |

Control Arms

When Quality is the Aim

Add a cool new look to your ride and lower your curb weight with Speedmaster™ control arms. These control arms are manufactured to strict tolerances to employ a great fit and exceptional performance.

Features:

- Stronger than the factory control arm
- Improved suspension geometry
- Provides additional built in positive caster which improves your handling ability
- Urethane bump stops to provide ball joint protection at full drop
- No modifications required to install the control arms
- Complete factory replacement
- Low drag and self lubricating properties for a bind free operation
- Bushings do not squeak and are high wearing
- Control arms come powder coated with new hardware
- Sway arm bushings and mounts

Huge tube design for less Deflection

Special cam plugs allow for more caster adjustment, giving vehicle more high speed stability. These will work with stock/standard coil springs and even coil overs. Anything you can use on the stock arms you can use with these.



- | | | |
|---|---|---|
| a. PCE179.1001 Camaro 1967-69 Nova 1967-74 Front Tubular Lower - Pair | e. PCE179.1002 Chevy Chevelle Monte Carlo Gto A Body 1968-72 Front Tubular Upper - Pair | Upper & Lower Sets:
PCE179.1011 Camaro 1967-69 Nova 1968-74
PCE179.1013 Chevelle Monte Carlo GTO A Body 1964-67
PCE179.1012 Chevelle Monte Carlo GTO A Body 1968-72
PCE179.1010 Ford Mustang II 1974-78 Set (Coil Over)
PCE179.1008 Ford Mustang II 1974-78 Set (Coil Spring) |
| b. PCE179.1003 Camaro 1967-69 Nova 1967-74 Front Tubular Upper - Pair | f. PCE179.1007 Ford Mustang II 1974-78 Tubular Lower (Coil Over) - Pair | |
| c. PCE179.1004 Chevy Chevelle Monte Carlo GTO A Body 1964-72 Front Tubular Lower - Pair | g. PCE179.1006 Ford Mustang II 1974-78 Tubular Upper (Coil Over) -Pair | |
| d. PCE179.1005 Chevy Chevelle Monte Carlo Gto A Body 1964-67 Front Tubular Upper - Pair | h. PCE179.1009 Holden LC-LJ LH-LX HQ-WB Upper Adjustable Trailing Arm - Pair | |
| | i. PCE179.1009 Holden LC-LJ LH-LX HQ-WB Upper Adjustable | |

Spindles

Do you need service parts for your brakes? Whether your ride is stock or going lower, you can trust Speedmaster™ disc brake spindles. Speedmaster™ one-piece steel disc brake spindles are great replacements for worn pieces. Speedmaster™ spindles make it easy to retrofit cars already equipped with OEM single-piston disc brakes or aftermarket kits that bolt to the stock disc brake spindles. Steering geometry remains unchanged, since they are direct bolt-ons to stock steering arms. For quality braking parts at a price that you can afford, choose Speedmaster™



Application	Ride Height	Spindle Material	Quantity	SKU
Ford Mustang II 1974-78	Stock	Forged steel	Individual - Left	PCE180.1001
			Individual - Right	PCE180.1002
Ford Mustang II 1974-78	Lowered 2"	Forged steel	Individual - Left	PCE180.1003
			Individual - Right	PCE180.1004
Ford Early Model 1928-48	Stock	Forged steel	Pair	PCE180.1005
			Pair (w/Pin Kit)	PCE180.1006
GM A-F and A Body Front	Stock	Steel	Pair	PCE180.1007
GM 1955-57 TRI 5 Front	Lowered 2"	Steel	Pair	PCE180.1008

Pitman Arms

Speedmaster™ precision-built pitman arms are not only manufactured to strict tolerances using the latest steering technology, but they are also given a virtually rustproof, trick-looking black coating for added durability! They are lab-tested and real-world proven to ensure crisp, predictable handling and reliability.



Application	Steering Box	SKU
1968-72 525 605 Manual	32 Ford Vega	PCE499.1001
1964-67 525 605 Manual	32 Ford Vega	PCE499.1002
1968-72 GM 600/700	32 Ford Vega	PCE499.1003
1964-67 GM 600/700	32 Ford Vega	PCE499.1004

Coil-Over Springs

Speedmaster™ coil springs are designed to withstand the high stress levels of modern suspensions. They're manufactured from high-quality chrome silicone steel, heat-treated and shot-peened, and then Silver powdercoated for protection and appearance. Each spring is guaranteed to be within five percent of its advertised rate.



Coil-Over Spring Length (in)	Coil-Over Spring Inside Diameter (in)	Coil-Over Spring Rate (lbs/in)	SKU
12.000 in.	2.500 in.	110 lbs./in.	PCE493.1001
		130 lbs./in.	PCE493.1002
		150 lbs./in.	PCE493.1003
		170 lbs./in.	PCE493.1004
		200 lbs./in.	PCE493.1005
		450 lbs./in.	PCE493.1006
		550 lbs./in.	PCE493.1007

Coil-Over Shock Assemblies

Speedmaster™ has put together these coil-over shock and spring value packs to help you replace your OEM rear suspension and help your race car be more consistent on starting line launches. They include a pair of adjustable coil-over shocks and a pair of silver powdercoated coil-over springs. The Speedmaster™ coil-over shock and spring are available with a variety of spring rates that you can match to the specific rear weight of your vehicle. Stop wasting precious time on the starting line pick up one of these Speedmaster™ coil-over shock Assemblies and outrun your competition.



Coil-Over Kit Position	Internal Design	Extended Length (in)	Collapsed Length (in)	Upper & Lower Mount	Shock Body Material	Shock Body Finish	Spring Finish	Spring Rate (lbs/in)	SKU
Rear	Twin-tube	13.840 in.	10.000 in.	Eyelet(5/8")	Aluminum	Natural	Black Powdercoated	150 lbs./in.	PCE494.1001
								180 lbs./in.	PCE494.1002
								200 lbs./in.	PCE494.1003
								250 lbs./in.	PCE494.1004
								300 lbs./in.	PCE494.1005
								350 lbs./in.	PCE494.1006

Steering Components

Power Steering Pumps

Speedmaster™ power steering pumps turn your power steering system into a showpiece. They are direct replacements for your old used-up OEM pump.



Ref.	Application	Power Steering Pump Model	Reservoir Included	Reservoir Style	Inlet Attachment	Inlet Size	Outlet Attachment	Outlet Size	Pulley Attachment Style	SKU
a.	GM 1963-74	Saginaw P series	Yes	Attached	Hose barb	3/8 in.	Female threads	5/8-18 in.	Keyway	PCE172.1002
b.	GM 1975-79	Saginaw P series	Yes	Attached	Hose barb	3/8 in.	Female threads	5/8-18 in.	Keyway	PCE172.1001
c.	GM 1980-01	GM Type 2	No	Remote	Female threads	Stock	Nipple	Stock	Press-fit	PCE172.1003

Power Steering Reservoirs

Speedmaster™ power steering tanks are manufactured from high-grade aluminum. They are baffled for proper fluid control and come with the necessary brackets for installation in the factory position. Help out your power steering with one of these Speedmaster™ power steering tanks.



Ref.	Application	Inlet Attachment	Outlet Attachment	Notes	SKU
a.	Ford Mustang 1999-04	Nipple	Nipple	-	PCE173.1001
b.	Dodge 2005-12 2.7L to 6.1L	Nipple	Nipple	-	PCE173.1002
c.	Universal	Male threads	Male threads	Billet Aluminum 8.5 in. x 2.5 in.	PCE173.1003

Steering Boxes

Speedmaster™ steering boxes are made from totally new components, these boxes have improved designs. Needle bearings, precision worm and nuts, stronger casting designs, and quicker ratios are just a few of the great features found in these steering boxes.



Application	Steering Box Style	Steering Box Type	Steering Ratio	SKU
32 Ford Model A Street Rod/Vega	Front steer	Manual	20:1	PCE500.1001

Driveshaft Safety Loops

The failure of a U-joint or driveshaft can have big consequences, ranging from major vehicle damage to slinging a driveshaft toward bystanders. Speedmaster™ safety loops surround the driveshaft with a heavy-gauge steel cage that restrains the shaft after a failure, making things safer for you and everyone nearby.



Application	Installation	Style	Adjustable	Material	Finish	SKU
Universal	Bolt-on	Flat	Yes	Steel	Zinc plated	PCE430.1001

Automatic Transmissions

Reliable Performance

This transmission is designed for a performance street application. It is built stronger than stock with upgraded components. This transmission is designed to have a nice "firm" shift but still tame enough to be driven daily without breaking your neck. The same care that we take to assemble our engines is used to remanufacture our transmissions.

Everyone of our transmission goes through the following:

- Teardown where the transmission is disassembled to a bare case and its components, including the removal of bushings and disassembly of the valve body.
- The bare case is cleaned in a aluminum jet cleaner and has the passages further cleaned using compressed air, while the valve body and its parts that are to be reused are thoroughly cleaned.
- The cleaned case is then inspected for cracks, pin holes or wear. The valve body surfaces are checked and machined as necessary, while the valves are checked for drag to ensure correct smooth operation.
- The turbine fins are inspected, retightened and welded. The hubs are carefully inspected and replaced as needed. Washers, spacers, springs, rollers and new relined clutch piston is then installed.

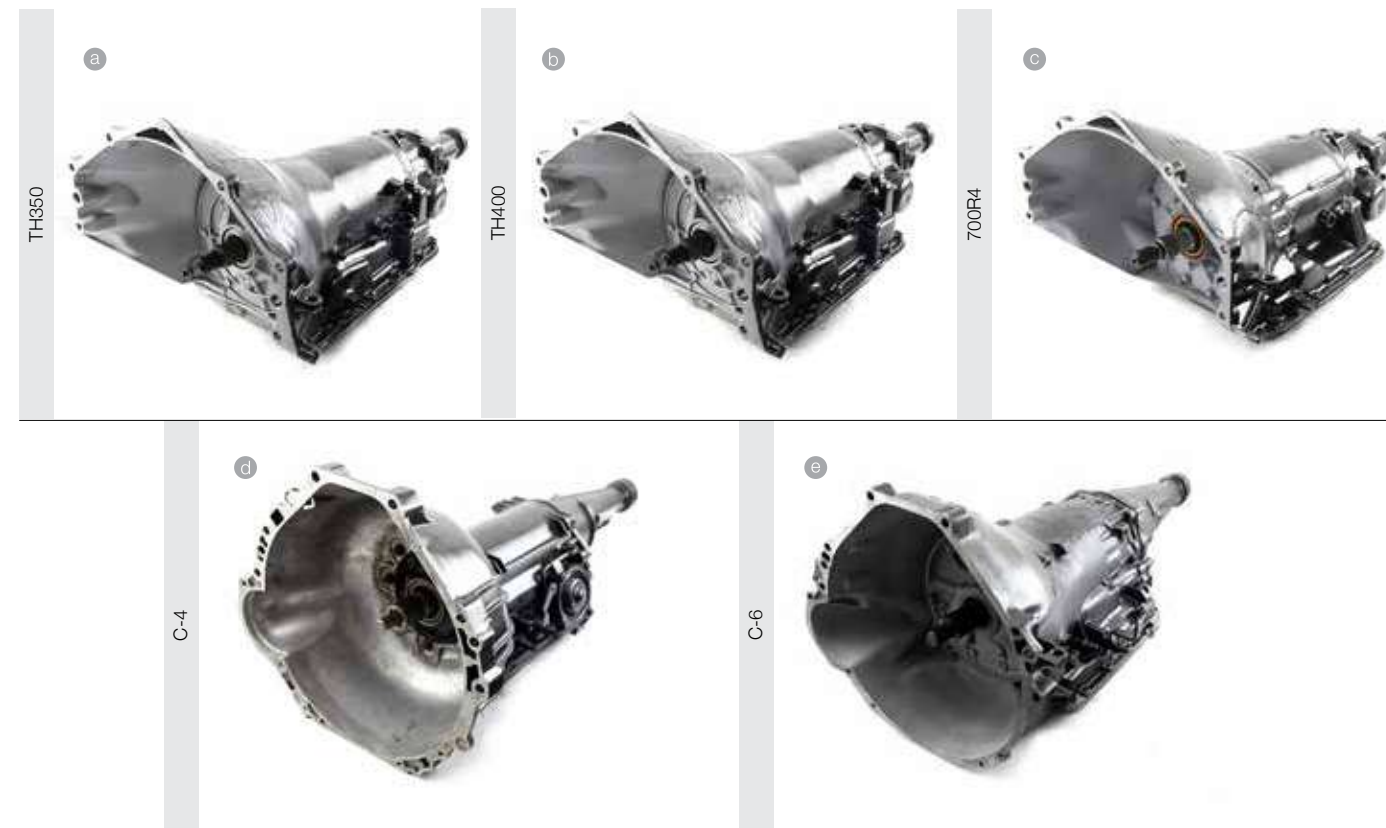

a. PCE432.1001 Turbo 350 Th-350 Gm
b. PCE432.1002 Turbo 400 Th-400 Gm

c. PCE432.1003 Turbo 700R-4 Th700R-4 Gm
d. PCE432.1004 Ford C4

e. PCE432.1005 Ford C6

Automatic Transmission Pans

Standard-Depth

Speedmaster™ standard-depth automatic transmission pans are quality replacement for your pan. No modifications to the dipstick are needed, and these cast aluminum pans have a beautiful polished finish for great looks.

Deep

Speedmaster™ deep automatic transmission pans provide additional fluid capacity and cooling ability. No modifications to the dipstick are needed. They include a drain plug for clean and easy fluid changes. They feature a cast aluminum construction that not only adds strength and structural integrity to the transmission but helps dissipate heat and keeps the fluid cooler. The extra fluid these pans accommodate also allows torque converters to lock up better with some added horsepower.



a. PCE221.1004 TH350 STD Finned Polished
b. PCE221.1013 TH350 +3qt Finned Natural
c. PCE221.1005 TH400 STD Finned Polished

d. PCE221.1008 TH400 +2qt Finned Natural
e. PCE221.1006 700R4 STD Finned Polished
f. PCE221.1007 Powerglide +2qt Finned Natural

g. PCE221.1009 C-4 +2qt Finned Natural
h. PCE221.1012 Torqueflite 727 +2qt Finned Natural

Flywheels and Flexplates

Born for High-RPM

The transmission can be one of the more confusing parts of a vehicle, but also one of the most important. Transmissions - whether manual or automatic - essentially take the power from the engine and apply it to the drive wheels. As such, this is one of the most critical systems in any car. Flywheels are used in manual transmissions and flexplates are used exclusively for automatics; essentially they serve as the link that marries the transmission to the engine.



Quick Tip

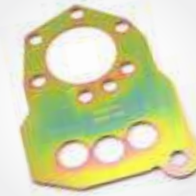

Counter Balance Plates

Speedmaster™ counter balance plates are required when using an internal balance flexplate or flywheel with any external balance crankshaft. This plate installs easily between the crank flange and driveplate using stock length bolts.

PCE224.1001 Chevrolet SBC 350 BBC 454



Flywheels

Manual Transmissions

Speedmaster™ flywheels are fully CNC machined from a high tensile aircraft billet steel. The high carbon steel material is incredibly strong and can withstand the rigors of the most extreme engines, drivers, and road conditions. Grab one of these race-ready Speedmaster™ billet steel flywheels for the durability and performance that you demand at a great price! To withstand the severe abuse of high-rpm racing in heavy drag cars, use Speedmaster™ billet steel flywheels. Most are drilled for both Borg & Beck and Long-style clutch assemblies.



Ref.	Application	Ring Gear Tooth Quantity	Rear Main Seal Style	Engine Balance	SKU
a.	Chevrolet SBC 350 Late	153-tooth	1-piece	External	PCE229.1004
		168-tooth			PCE229.1005
b.	Chevrolet SBC 350	153-tooth	2-piece	Internal	PCE229.1001
		168-tooth			PCE229.1002
c.	Chevrolet SBC 400	168-tooth	2-piece	External	PCE229.1003
d.	Chevrolet BBC 454	153-tooth	2-piece	External	PCE229.1007
		168-tooth			PCE229.1008
e.	Ford SB 289 302 351 351C Windsor	157-tooth	-	External, 28 oz.	PCE229.1009
		164-tooth			PCE229.1011
f.	Ford SB 289 302 351 351C Windsor	157-tooth	-	External, 50 oz.	PCE229.1010
		164-tooth			PCE229.1012
g.	Ford 429 460	164-tooth	-	Internal	PCE229.1013
		184-tooth			PCE229.1013
h.	GM LS1 LS2 LS3 LS6 LS7 L76	168-tooth	-	Standard	PCE229.1006
i.	Holden 253 304 308	158-tooth	-	Internal	PCE229.1014



Flexplates

Automatic Transmissions

Speedmaster™ flexplates make excellent upgrades to your stock design. They feature extra-thick steel that's double-welded to the ring gear for added strength and anodized for corrosion resistance. Speedmaster™ flexplates will withstand the extreme power and rpm of today's engines.

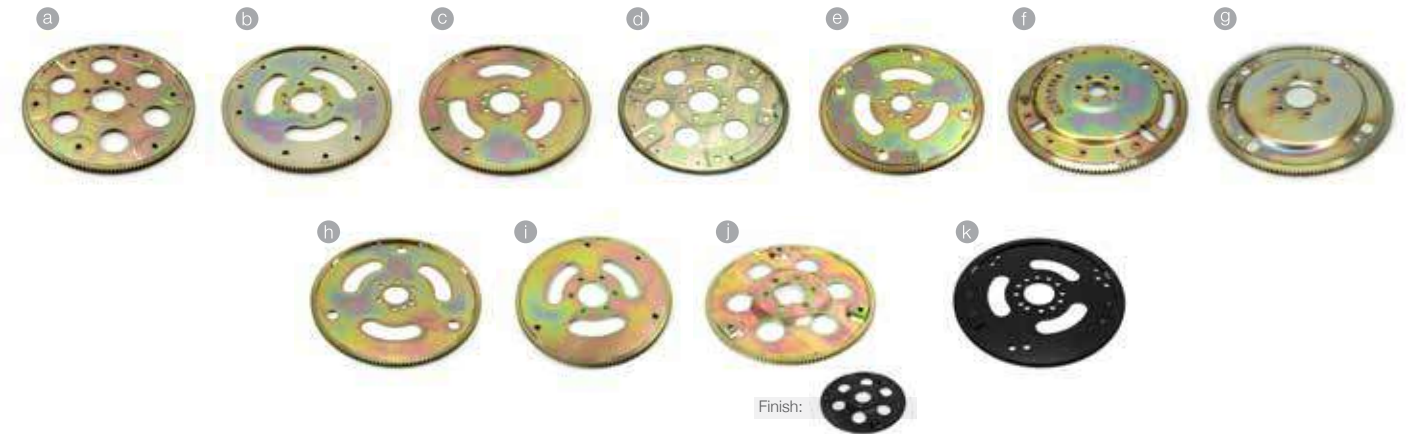

Ref.	Application	Ring Gear Tooth Quantity	Rear Main Seal Style	Engine Balance	SKU
a.	Chevrolet SBC 350 Late	153-tooth	1-piece	Standard	PCE226.1004
		168-tooth			PCE226.1005
b.	Chevrolet SBC 350	153-tooth	2-piece	Internal	PCE226.1001
		168-tooth			PCE226.1002
d.	Chevrolet SBC 400	168-tooth	2-piece	External	PCE226.1003
c.	Chevrolet SBC 400 (350 Removing Weight)	168-tooth	2-piece	External (Internal Removing Weight)	PCE226.1007
		153-tooth			PCE226.1007
d.	Chevrolet BBC 454	153-tooth	2-piece	External	PCE226.1007
		168-tooth			PCE226.1008
e.	Ford SB 289 302 351 351C Windsor	157-tooth	-	External, 28 oz.	PCE226.1012
		163-tooth			PCE226.1009
f.	Ford SB 289 302 351 351C Windsor	157-tooth	-	External, 50 oz.	PCE226.1013
g.	Ford 429 460	164-tooth	-	External	PCE226.1010
h.	GM LS1 LS2 LS3 LS6 LS7 L76	168-tooth	-	Standard	PCE226.1006
i.	Holden 253 304 308	158-tooth	-	Internal	PCE226.1011
j.	Holden 253 304 308 (OEM Style)	158-tooth	-	Internal	PCE226.1015
					Black Edition
k.	Oldsmobile V8	166-tooth	2-piece	External	PCE226.1014

Transmission Components

Automatic Transmission Shift Kits

Speedmaster™ Shift Improver Kit can be installed in one of two modes.

Stage - 1 RV/Heavy Duty

Firm positive shifts without loss of driver comfort for improved performance in all street vehicles. Recommended for regular passenger vehicles, RV's, fleet, etc.

Stage-2 Street/Strip

Provides very positive shifts for high performance street use or for competitive events. This model is for the enthusiast who wants the hardest, quickest possible shift.

These Speedmaster™ Shift Improver kits are the easiest way to get the stout performance you've always wanted out of your automatic transmission. All you need are some hand tools and an afternoon and you can turn your transmission into a tuned unit. Each kit has two stages to fit your needs: RV/heavy duty and Street/Strip.



Transmission Type	SKU
TH350	PCE222.1006
TH400	PCE222.1007
700R4	PCE222.1001
4L60E	PCE222.1002
C4 1967-69	PCE222.1004
C4 1970-82	PCE222.1005
C6 1967-91	PCE222.1003

Shifters

Put your hands on it

Speedmaster™ rock-solid race shifting Billet Street automatic shifters can give your street ride the feel of having a full-on race stick in your hand. Hot looks and smooth changes up and down the range help these sweet pieces of shifter technology put the fun back into your automatic. The design is clean, smooth, and functional, it has just the right look for your street machine!

Ideal for high-tech pro-street & street rod type vehicles. Narrow styled aluminum housing.

Includes neutral safety switch, backup light switch and billet aluminum handle.

- Speedmaster™ Quality
- Forward and Reverse Shift Patterns
- Firm, Comfortable, Natural Grip When Shifting
- Less Chance Of Hand Slipping And Missing A Shift
- CNC Machined from Solid Billet Aluminum

Suits:

General Motors - TH400, 350, 250, 200, 700-R4, 200-4R

Ford - C4 & C6 or AOD* w/ aluminum cover (* AOD Installation requires additional parts).

Chrysler - '66 & later Torqueflite 727 & 904 w/ aluminum cover



Shifter Style	Shift Mechanism	Reverse Lockout	Knob Included	Knob Style	Shifter Stick Length (in)	Cable Entry	Cable Included	Linkage Included	Shifter Finish	SKU
Cable operated	Gate	Yes	Yes	Pistol grip	8.000 in.	Rear	Yes	Yes	Natural	PCE220.1003
									Black	PCE220.1004

Kickdown Cables

Speedmaster™ kickdown kits have PTFE-lined cables, which are made with an extruded liner for extended life. These kickdown kits feature aluminum fittings and ferrules to eliminate frayed ends. They are adaptable to all types of manifolds, including tunnel ram, blower manifolds and multiple-carburetor systems.

PCE224.1001 Stainless Steel Braided

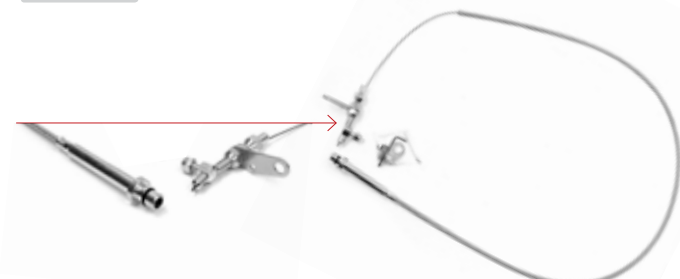

Flywheel Dust Covers

Speedmaster™ flywheel allow for easy access to the torque converter area and prevent debris from entering your transmission's bellhousing.



Transmission Type	Material	Finish	SKU
TH350, TH400	Aluminum	Polished	PCE227.1002
TH350, TH400	Steel	Chrome	PCE227.1003
Powerglide	Steel	Chrome	PCE227.1001

Shifter Components

Shifter Cables

Speedmaster™ high-quality steel cables have a nylon liner and are pre-lubricated for smooth operation. The red cover is heat-resistant for longer life and more dependable service. They have one threaded and one eyelet end to fit most aftermarket cable-operated automatic shifters.



Overall Cable Length	Suits	SKU
4 ft.	B&M	PCE219.1001
4 ft.	Hurst	PCE219.1002

Gate Plates

Speedmaster™ gate plates are bolt-on options to convert your standard-pattern shifter. They will allow for the use of reverse-style transmission valve bodies or switching from a 3-speed to a 4-speed. Best of all, you reuse all of your existing Speedmaster™ shifters parts, levers, mechanisms and cable no modifications are required for installation.



Description	Shifter Pattern	SKU
2-Speed	Forward	PCE218.1001
3-Speed	Forward	PCE218.1002
4-Speed	Forward	PCE218.1003

Brackets

These bracket and lever kits allow you to use a B&M or Hurst cable operated shifter with the Holden Trimatic transmission. Available for transmissions with either drivers side or passenger side shift linkages, check your transmission to see which kit is required.



Shift Linkage Side	Suits	SKU
RH	Holden GM Trimatic	PCE217.1004
LH	Holden GM Trimatic	PCE217.1005

Brake Systems

Master Cylinders

Do you need a replacement master cylinder for your braking system? Speedmaster™ master cylinders will increase performance and reliability. Speedmaster™ manufactures these master cylinders from quality materials to ensure proper fitment. They are equipped with 1 1/8 bores and a high luster finish for just the right look. Bolts right on to our brake boosters.

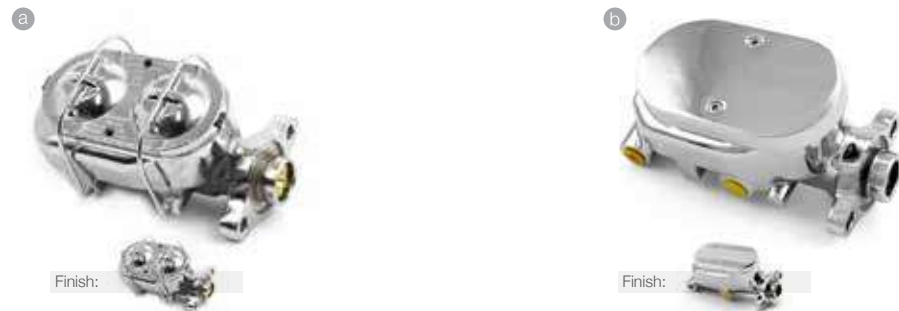

Brake Boosters

Speedmaster™ brake boosters are the perfect addition to your street rod or custom application. Have you lost that vacuum feeling? If you're pushing your brake to the floor, it may be that your brake booster needs replaced, and Speedmaster™ has brake boosters for you.

Single Diaphragm



Dual Diaphragm



a. PCE166.1002 Clip On Top Aluminum
PCE166.1001 Steel

b. PCE166.1003 Screw On Smooth Top Aluminum
PCE166.1004 Finned Top

c. PCE165.1007 7" Universal Single Diaphragm Chrome
PCE165.1008 Zinc

d. PCE165.1009 9" Universal Single Diaphragm Chrome
PCE165.1010 Zinc
PCE165.1011 Black

e. PCE165.1006 11" Universal Single Diaphragm Chrome
PCE165.1005 Zinc

f. PCE165.1001 7" Universal Dual Diaphragm Chrome
PCE165.1002 Zinc

g. PCE165.1003 8" Universal Dual Diaphragm Chrome
PCE165.1004 Zinc

h. PCE490.1001 Billet Power Brake 12V Electric Kit

i. PCE492.1001 2 PSI RPV

j. PCE492.1002 10 PSI RPV

Vacuum Pumps, Street

Cars with big cams may run a little short on vacuum for their power brake boosters. For all of the vacuum that you need, just install one Speedmaster™ electric vacuum pump kits. They include a shiny 12 V pump and all of the vacuum line, fittings, and hardware required for installation. The units are completely self-contained, with no need for the additional wiring of relays or switches--simply supply power to the units and they regulate themselves. When vacuum levels drop below 15 hg, the electric vacuum pumps activate and increase brake vacuum to 20 hg.



Residual Pressure Valves

Ideal for drag racing, street rods and many off-road applications, these inline residual pressure valves from Speedmaster™ retain a minimum brake line pressure to help eliminate excessive pedal travel.



Quick Tip



Residual Pressure Valves are used in a both front and rear brake system as follows:

2 PSI Valves - These valves are used in a disc brake system only and are required when the master cylinder is at, or below, the height of the calipers. It's purpose is to act as an anti-siphon valve preventing the brake fluid from siphoning back into the master cylinder when the brake pedal is released. Even if the master cylinder is even or slightly above the calipers, put one in anyway. If you don't and you park on a hill, fluid will siphon! These valves are cheap insurance - put them in!

10 PSI Valves - These valves are used in a drum brake system to prevent air from being ingested into the hydraulic system when you release the brake pedal. Typical wheel cylinder seals only seal when there is pressure behind them. Rapid release of the brake pedal creates a vacuum in the system which causes the seals to relax and air is ingested into the wheel cylinders. Maintaining 10 PSI in the system at all times prevents this.

Typical Disk/Drum Configuration

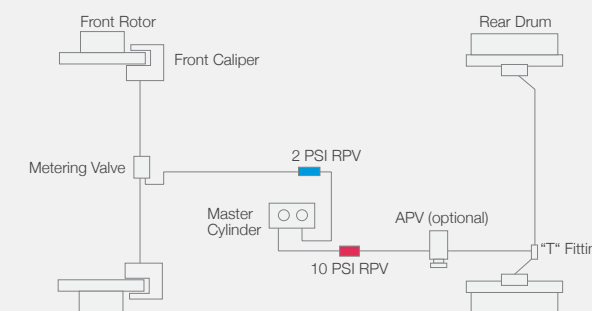

Typical Disk/Disk Configuration

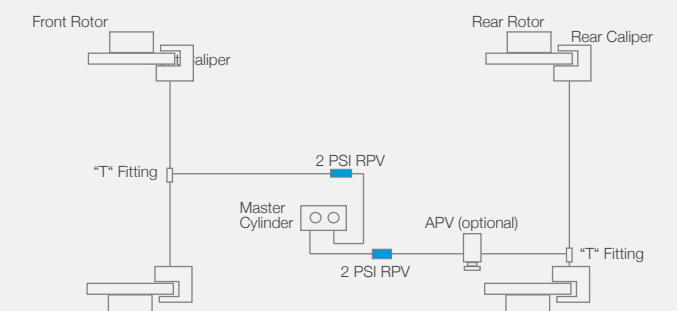



SPEEDMASTERTM

SPEEDMASTERTM

SPEEDMASTERTM

SPEEDMASTERTM

VICTORIAN
AMERICAN
IMPORTS

I&H

K-TRANS

TRUCK WORLD

SECO MeasumaX^{MX}



Turnkey EFI

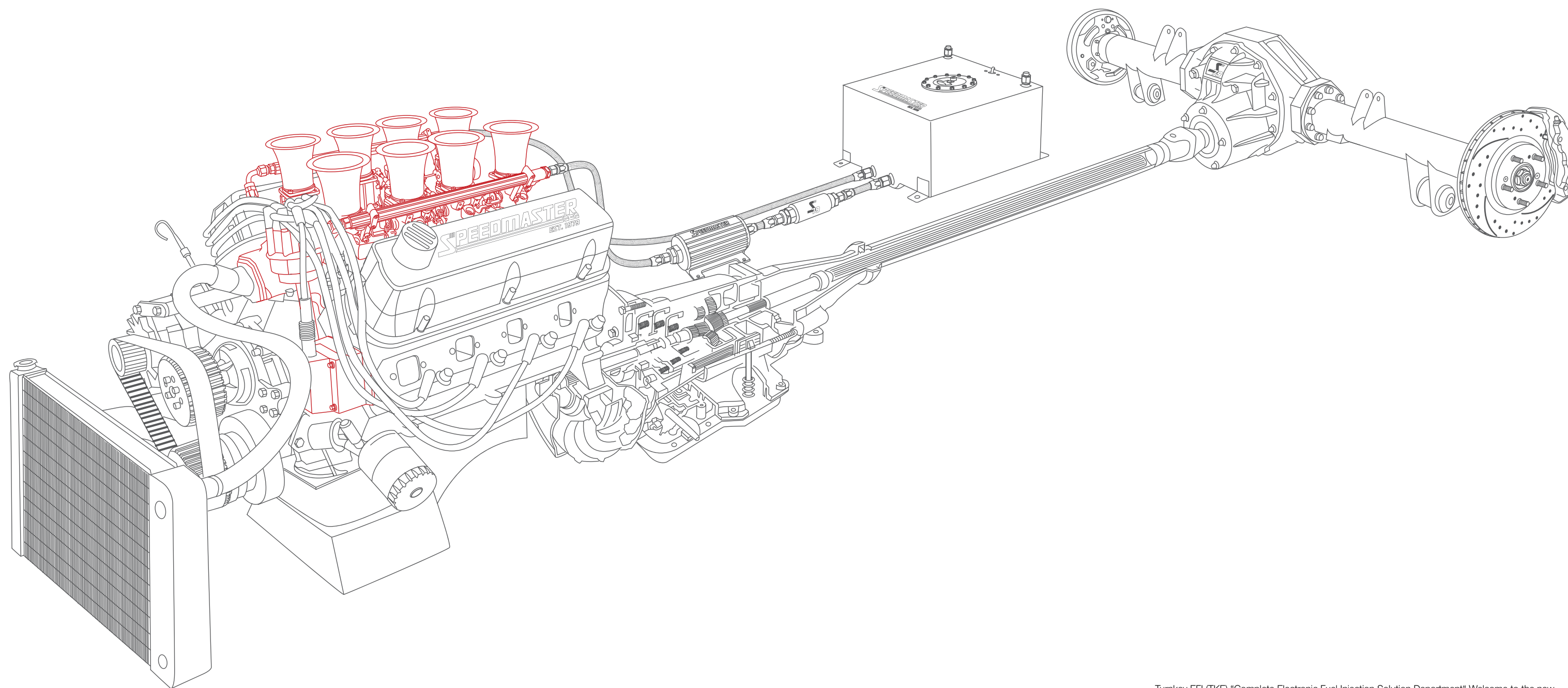

Turnkey EFI (TKE) "Complete Electronic Fuel Injection Solution Department" Welcome to the new era in fuel injection! Introducing Turnkey EFI. Our kits include everything you need to convert from a carb to a modern EFI system. Our ECU can be operated in a Self-Mapping mode to cut down on set-up time, or Manual-Mapping for those people who want a specific tune. Why run an antiquated carburetor when you can install one of our kits in less than two hours, and have total control over the engine at your fingertips.

Fuel Injection Systems

Tuned Performance

Welcome to the new era in fuel injection! Introducing Turnkey EFI. Speedmaster™ line of EFI systems is all you need when deciding to upgrade your engine to modern electronic fuel injection. Our EFI systems provide excellent throttle response throughout the RPM range along with smooth engine operation. They also offer the potential for improved fuel economy by making the engine more efficient. Speedmaster™ EFI systems give you everything you need to add powerful and efficient fuel injection to your vehicle. All our systems are dyno-tested to deliver proven-performance results. Finally, Speedmaster™ offers a dedicated support staff to assist you and answer any questions. Speedmaster™ EFI systems offer you the most value for your dollar!

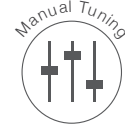
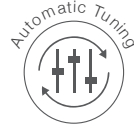

Single TB



Individual TB



All you Need

Our kits include everything you need to convert from a carb to a modern EFI system. Our ECU can be operated in a Self-Mapping mode to cut down on set-up time, or Manual-Mapping for those people who want a specific tune. Why run an antiquated carburetor when you can install one of our kits in less than two hours, and have total control over the engine at your fingertips.



Speedmaster™ EFI Systems have won 2010, 2011 & 2013 Sema Show Global Media Award.

The Speedmaster™ development team have been pushing the boundaries for years with a main objective "to improve the end user experience"; one of the many industry acknowledgments are the 5 in a row SEMA Show Global Media Awards for their research and development of their Pistons, Turnkey EFI system and Manifolds.

Scan to Watch the Turney EFI system in Action

Speedmaster™ EFI Systems Include:

- Engine Control Unit (ECU)
- Coolant Temp Sensor
- Throttle Position Sensor
- Wideband O2 Sensor
- V8 Wiring Harness For EFI (Includes Injector Harness)
- Communication Cable (Db9)
- USB / Serial Port Adapter
- Pro Billet Distributor (Advance Locked Out / Magnetic Pickup)
- High Output E-Core Ignition Coil
- Fuel Rail Kit Anodized with Fittings, Crossover Hose & Plugs
- Intake Gasket Set
- Software Pack
- Instruction Manual

Also included in The Single Throttle Body Line:

- Idle Air Control Motor
- Intake Manifold with Drilled Injector Ports
- Billet Throttle body
- Throttle Body Base Gasket (4150 Only)
- Carburettor / TB Studs 5/16" x 20x1.350"

Also included in The Individual Throttle Body Line:

- Individual Throttle Body Manifold with Trumpets

Optional Fuel System Components

Injectors

PCE136.1001	Injector 24 lbs / hr
PCE136.1002	Injector 36 lbs / hr
PCE136.1003	Injector 60 lbs / hr
PCE136.1004	Injector 80 lbs / hr

Fuel Pumps

PCE145.1014	450 lbs./ Hr. High Pressure Fuel Pump
PCE145.1015	800 lbs./ Hr. High Pressure Fuel Pump
PCE145.1016	1000 lbs./ Hr. High Pressure Fuel Pump

Regulators

PCE139.1011	-6AN EFI Fuel Pressure Regulator Black
PCE139.1014	-8AN EFI Fuel Pressure Regulator Black
PCE139.1017	-10AN EFI Fuel Pressure Regulator Black

Accessories

PCE132.1011	Billet In Line Fuel Filter -6AN
PCE132.1012	Billet In Line Fuel Filter -8AN
PCE132.1013	Billet In Line Fuel Filter -10AN
PCE357.1004	100 PSI Fuel Pressure Gauge
PCE339.****	Braided Fuel Line -6 / -8 / -10
PCE333.1017	1/2" To 3/8" NPT Reducer Bushing (For Coolant Temp Sensor)
PCE390.****	High Performance ignition plug wires



Fuel Injection Systems

Single TB Superstreet Series

The TurnKey EFI Single throttle body system gives you the core components needed to convert a carbureted engine to modern electronic fuel injection. This universal EFI system is easy to install, self maintaining and delivers performance that is capable of supporting up to 700 hp.

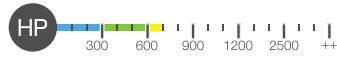

Application	Manifold Line	Manifold Finish	SKU
Chevrolet SBC 350	ITB Down-Draft	Natural	PCE135.1002
Ford SB 260 289 302 Windsor	ITB Down-Draft	Natural	PCE135.1016
Ford 351 Windsor	ITB Down-Draft	Natural	PCE135.1017

Individual TB Outlaw Series

The TurnKey EFI Individual throttle body system has all the flash of classic Weber induction with all the function, performance and versatility of modern fuel injection. This highly advanced system allows a broad camshaft selection and delivers performance that is capable of supporting up to 1000 hp. Fuel and air is delivered through precision cast aluminum 50mm IDA style throttle bodies that allow for superior idle characteristics and astounding throttle response while improving emissions and economy through tight air/fuel ratio control.

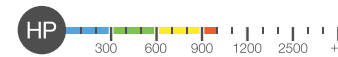

Application	Manifold Line	Manifold Finish	SKU
Chevrolet SBC 350	Shootout Pro	Natural	PCE135.1001
		Polished	PCE135.1003
Chevrolet BBC 454	Shootout Rect Port	Natural	PCE135.1004
		Polished	PCE135.1005
Ford SB 260 289 302 Windsor	Shootout	Natural	PCE135.1006
		Polished	PCE135.1007
Ford 351 Windsor	Shootout	Natural	PCE135.1008
		Polished	PCE135.1009
Pontiac 326 400 455	Eliminator	Natural	PCE135.1010
		Polished	PCE135.1011
Pontiac 326 400 455	Shootout	Natural	PCE135.1012
		Polished	PCE135.1013
Oldsmobile 400 425 455	Eliminator	Natural	PCE135.1014
		Polished	PCE135.1015





HARDY

KÄRCHER
ZONE

SPEEDMASTER™
EST. 1979

DENSO

SF

www.denosracing.com.au

WORTH



Turnkey Forced Induction

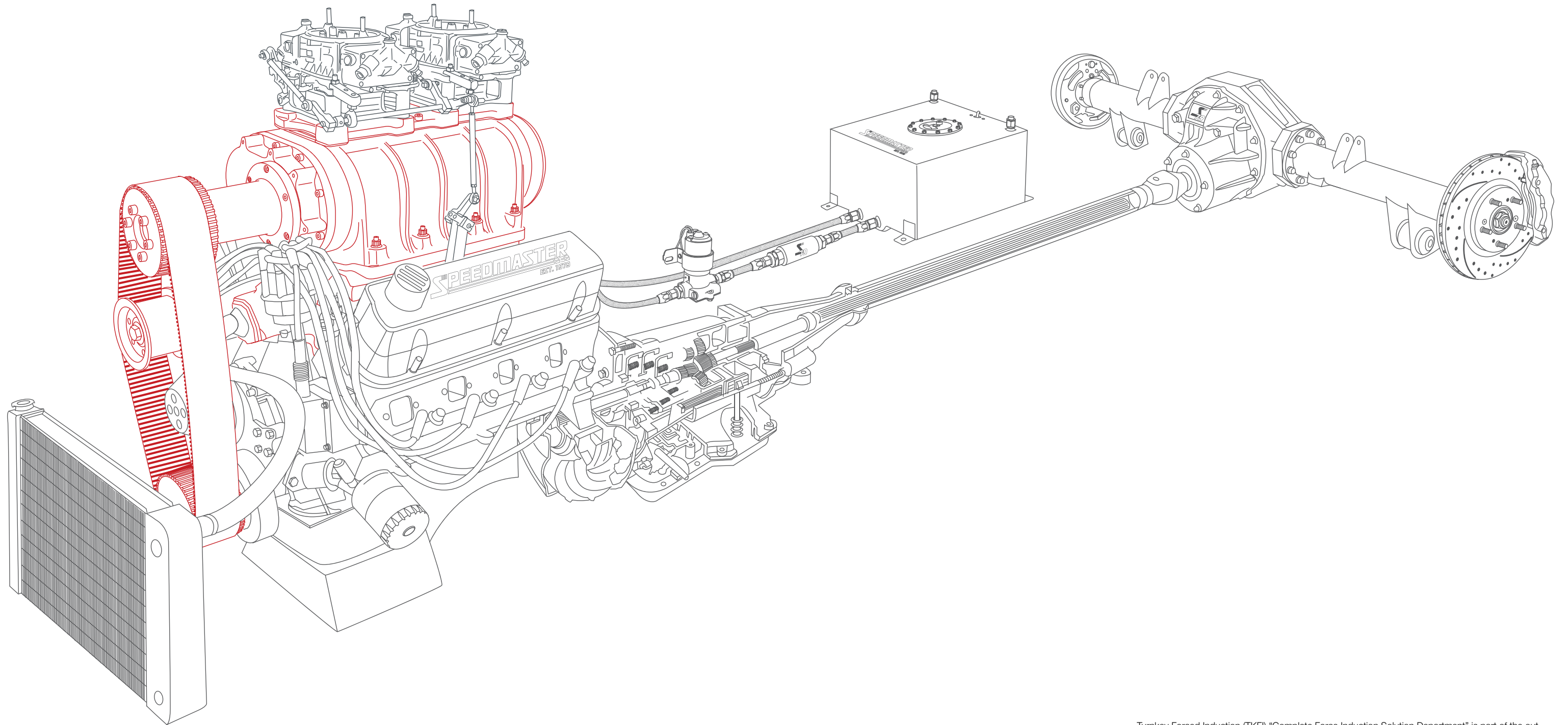

Turnkey Forced Induction (TKFI) "Complete Force Induction Solution Department" is part of the out-of-the-box solutions customers have gotten to love. Making things easier in parts selection, we have taken the guesswork out of components needed by actually placing the power package components together in complete kits. These kits include almost everything you need to make serious horsepower.

Superchargers Kits

It's all About Power

A supercharger is a compressor used to pump fresh air into the engine cylinders. Because more air, therefore oxygen, is forced into the cylinders this allows the engine to burn more fuel accordingly. The increased amounts of fuel and air in the cylinders cause a larger explosion in the cylinder when the spark plug is fired, subsequently more power is produced. In the process of powering a supercharger as much as a third of the total crankshaft power of the engine can be used, and in many applications superchargers are less efficient than the closely related turbocharger. However, because a turbocharger is powered by exhaust gases they suffer from 'turbo lag', this is because the pressure of the exhaust gas needs time to build up before spinning the turbine. Superchargers do not suffer from this problem, and in vehicles where power is more important than fuel economy superchargers are extremely common.

**+AIR MEANS +FUEL CAN BE ADDED,
+FUEL MEANS BIGGER EXPLOSION
= GREATER HORSEPOWER**

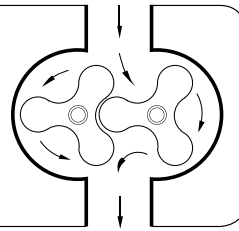

Let's boost your power output

Speedmaster's 6-71 Street Supercharger kits can give you 45-55 percent more streetable power. They feature double-pinned rotors (timed and cleared after assembly), heavy duty front and rear bearing plates, and an intake manifold. The kits also come with a one-piece aluminum nose drive assembly, upper and lower drive pulleys, an idler pulley and bracket, a dual V-belt accessory drive pulley, a 3 in. Gilmer-style drive belt, and gaskets and hardware. Speedmaster™ also includes an adapter plate for two 4 barrel carburetors.



Quick Tip 

Maintaining our Supercharged Car

Maintaining a supercharged car won't be much different than maintenance on any other vehicle. There are a few key differences and some things that need to be watched for.

Check oil levels. While it's important to keep proper oil levels on any vehicle, supercharged cars need to have special attention paid to this. The supercharge process creates more stress on the engine and without proper lubrication you can face very costly repairs later. Create a maintenance schedule that includes regular oil changes, and stick with it. It's not a good idea to use a synthetic oil in cars with a supercharger. The synthetic oil may last longer, but many car enthusiasts suggest using a conventional oil.

Use clean filters. A supercharged car relies on clean filters to perform at their maximum. A clogged or otherwise dirty filter will create more strain on the system, and can actually lead to more damage. An air filter in a supercharged vehicle will need to be replaced more often than in other types of vehicles. It's a good idea to change the air filter with every oil change.

Watch the clutch. Because of the added performance with a supercharged car, they tend to be driven much harder. This type of driving can lead to problems with the clutch because of the abuse that it takes. Have the clutch inspected regularly to avoid problems later.

Check tire alignment. For the same reason the clutch tends to go out quickly in a supercharged car, the tire alignment can get out of balance. It's a good idea to have the tires balanced regularly, and expect to spend extra money replacing tires more frequently with a supercharged vehicle.

Use the best gasoline. If you've already spent the money on upgrading your car to a supercharged system, it's worth the extra money to use the right fuel. Using fuel grades that are low will lead to poor performance, and can create excess gunk in the engine. Most manufacturers suggest at least a premium fuel, if not a premium plus level gas. You may save a few bucks at the pump to purchase cheap fuel, but your performance will suffer, and you may find yourself sinking more money in to engine repairs later down the road.

Upgrade the cooling system. A supercharged car relies heavily on the coolant system. Superchargers create excess temperatures in the engine compartment of the car. An engine that is allowed to get too hot will end up costing potentially thousands of dollars in repairs later. This is so important with a supercharged car that many manufacturers suggest upgrading the temperature gauges. It's a good idea to regularly check the coolant levels, and stop running the car immediately if the temperature gauge creeps up even a little bit.



SPEEDMASTER 79

SPEEDMASTER
EST. 1979

AWARD
WINNERS
3 IN A ROW

TRACK
PROVEN

707

SPEEDMASTER



Crate Motors

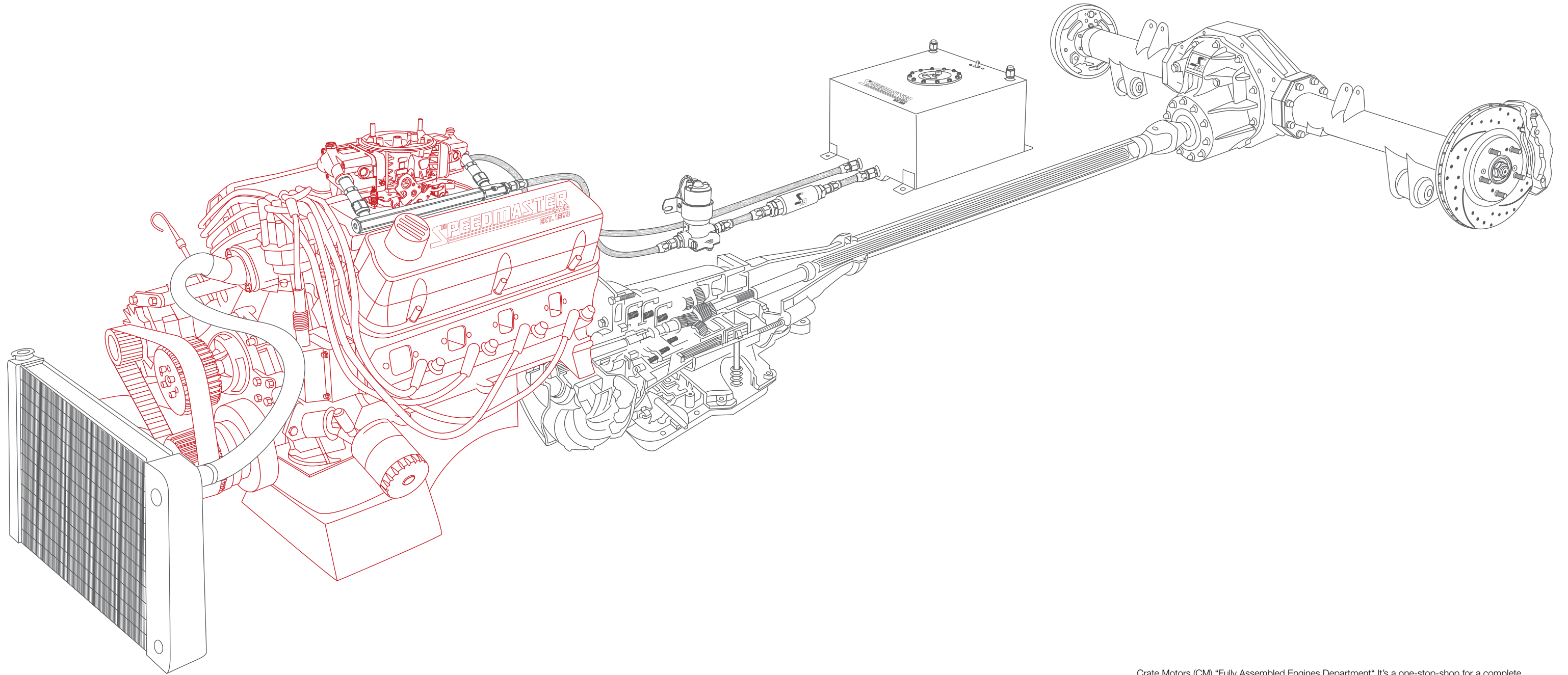

Crate Motors (CM) "Fully Assembled Engines Department" It's a one-stop-shop for a complete performance engine solution; incorporating all brand new parts that are designed to work with one another from the Speedmaster™ (and subsidiary) brand range. With unmatched value; you won't need to look around for all the parts needed when building an engine.

Choose & Relax

We will do the hard work for you



Get a brand new fully-assembled engine that's virtually ready to run and delivers Speedmaster™ performance right out-of-the-box. These engines include high-quality and performance Speedmaster Parts! Use our Crate Motors Decision Tree to get the right engine for your application.

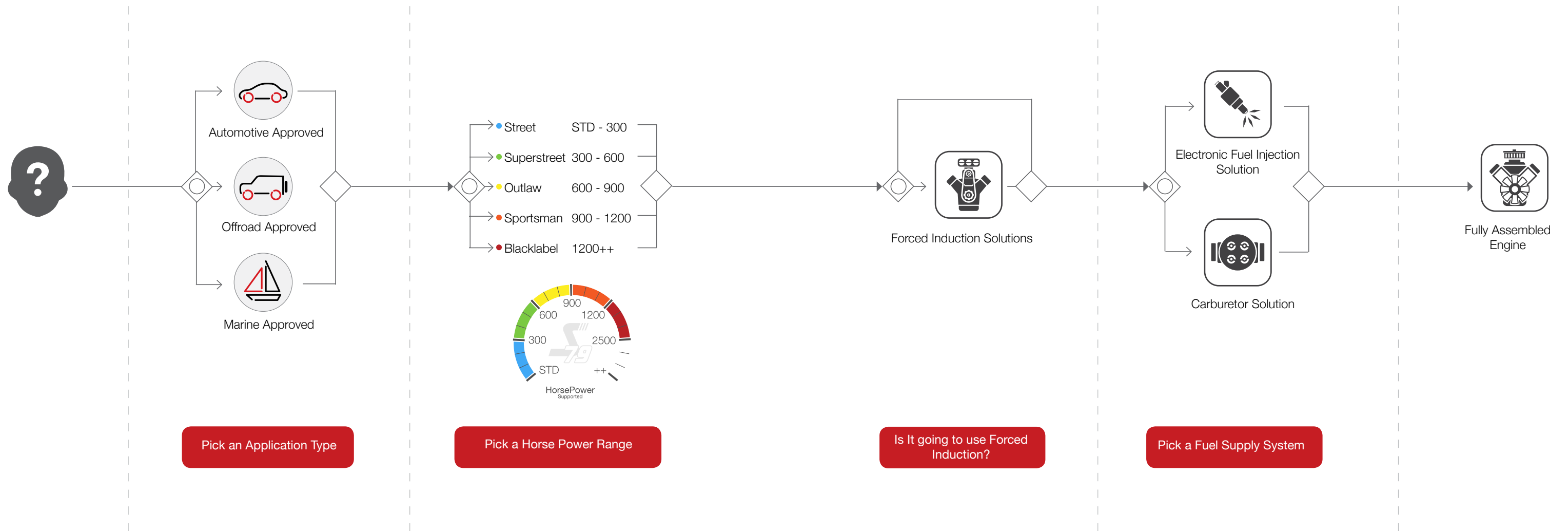

Crate Motors

Fully-Assembled

Speedmaster™ Crate Motors have been developed along side the research and development team to deliver drivable and reliable high performance engines. Fully assembled rotating assemblies are balanced within 2 grams with all new parts (OEM Block not included). Choosing a Speedmaster™ crate engine assembly assures that you're getting the performance and assembly you want with the possibility of upgrades, all at a great price.

Small Block Chevrolet

CM1001_ 4.000" @ 3.750" aka 383ci Stroker Crate Motor
 CM1002_ 4.000" @ 4.000" aka 400ci Stroker Crate Motor

Small Block Chevrolet Speedmaster™ Block (SMB)

CM1101_ 4.000" @ 3.750" aka 400ci Stroker Crate Motor
 CM1102_ 4.000" @ 4.000" aka 427ci Stroker Crate Motor

GM LS

CM1301_ 3.890" @ 4.000" aka 383ci Stroker Crate Motor
 CM1502_ 3.890" @ 4.150" aka 400ci Stroker Crate Motor
 CM1521_ 4.000" @ 4.000" aka 408ci Stroker Crate Motor
 CM1522_ 4.000" @ 4.150" aka 424ci Stroker Crate Motor

Big Block Chevrolet 454

CM1601_ 4.250" @ 4.250" aka 496ci Stroker Crate Motor

Small Block Ford 289 302 Windsor

CM2001_ 4.000" @ 3.400" aka 347ci Stroker Crate Motor
 CM2002_ 4.000" @ 3.470" aka 351ci Stroker Crate Motor

Small Block Ford 351 Windsor

CM3002_ 4.000" @ 3.850" aka 393ci Stroker Crate Motor
 CM3003_ 4.000" @ 4.000" aka 408ci Stroker Crate Motor
 CM3004_ 4.000" @ 4.170" aka 427ci Stroker Crate Motor

Small Block Ford 351 Windsor Speedmaster™ Block (SMB)

CM3102_ 4.000" @ 3.850" aka 393ci Stroker Crate Motor
 CM3103_ 4.000" @ 4.000" aka 408ci Stroker Crate Motor
 CM3104_ 4.000" @ 4.170" aka 427ci Stroker Crate Motor

CM3152_ 4.125" @ 3.850" aka 412ci Stroker Crate Motor
 CM3153_ 4.125" @ 4.000" aka 428ci Stroker Crate Motor
 CM3154_ 4.125" @ 4.170" aka 446ci Stroker Crate Motor
 CM3155_ 4.125" @ 4.250" aka 454ci Stroker Crate Motor

Ford Cleveland

CM4001_ 4.000" @ 3.750" aka 383ci Stroker Crate Motor
 CM4002_ 4.000" @ 3.850" aka 393ci Stroker Crate Motor
 CM4003_ 4.000" @ 4.000" aka 408ci Stroker Crate Motor

Holden

CM5001_ 4.000" @ 3.480" aka 355ci Stroker Crate Motor
 CM5002_ 4.000" @ 3.750" aka 383ci Stroker Crate Motor
 CM5003_ 4.000" @ 3.820" aka 396ci Stroker Crate Motor



Technical Specifications

Crank	Cast Steel Crank
Connecting Rods	"H" Beam 4340 Steel Rods
Pistons	Silicon Skirt Hypereutectic
Rings	Race Metric Moly "Z" Gap
Oil Pump	Standard Volume
Sump	Standard Volume
Fuel Pump	Mechanical (eccentric)
Water Pump	Mechanical Aluminum
Timing Chain	Dual Row 9 Key way
Gaskets	Mono-torque Head Gaskets
Balancer	Race Elastic
Bearings	"P" Series Style
Manifold	Aluminum Low Rise
Heads	Aluminum as Cast
Cam	Hydraulic Flat Tappet
Lifters	Hydraulic Flat Tappet
Pushrods	Hardened (Hydraulic Cam Only)
Roller Rockers	Aluminum (Hydraulic Cam Only)
Rocker Studs	3/8 Screw in studs
Guide Plates	5/16 Adjustable
Main Studs	12pt Nuts & Studs
Head Studs	12pt Nuts & Studs
Driveplate	H/Duty Flexplate
Rocker Covers	Aluminum tall to suit Rockers
Ignition	PC7000 Series / PC2042 Coil & Leads

Optional Upgrades

Crank	Forged Steel
Crank Girdle	Crank Main Girdle
Connecting Rods	"H" or Race "I" Beams
Pistons	Forged Full Floating
Sump	7 Litre HV Sump
Fuel Pump	140 GPH Electric & Reg
Water Pump	Electric Water Pump
Timing Chain	Billet Steel Gear Drive
Gaskets	Multi Layer Steel Head Gaskets
Balancer	Race Fluid Damper
Bearings	"H" Series
Manifold	Mid or High Rise
Heads	Aluminum CNC Ported
Cam	Solid Flat Tappet / Hydraulic or Solid Roller
Lifters	Solid Flat Tappet / Hydraulic or Solid Roller
Pushrods	.080 thou thick Pro Pushrods
Roller Rockers	Stainless Steel or Shaft Mount
Rocker Studs	7/16 Screw in studs
Rocker Girdle	3/18 or 7/16 Rocker Girdle
Driveplate	Billet Steel Flywheel
Rocker Covers	Billet Alloy Sheet Metal Welded
Starter Motor	High Torque Gear Reduction
Carburettor	750 - 950 CFM Outlaw
Ignition	CDI 6AL Ignition / PC2041 Coil

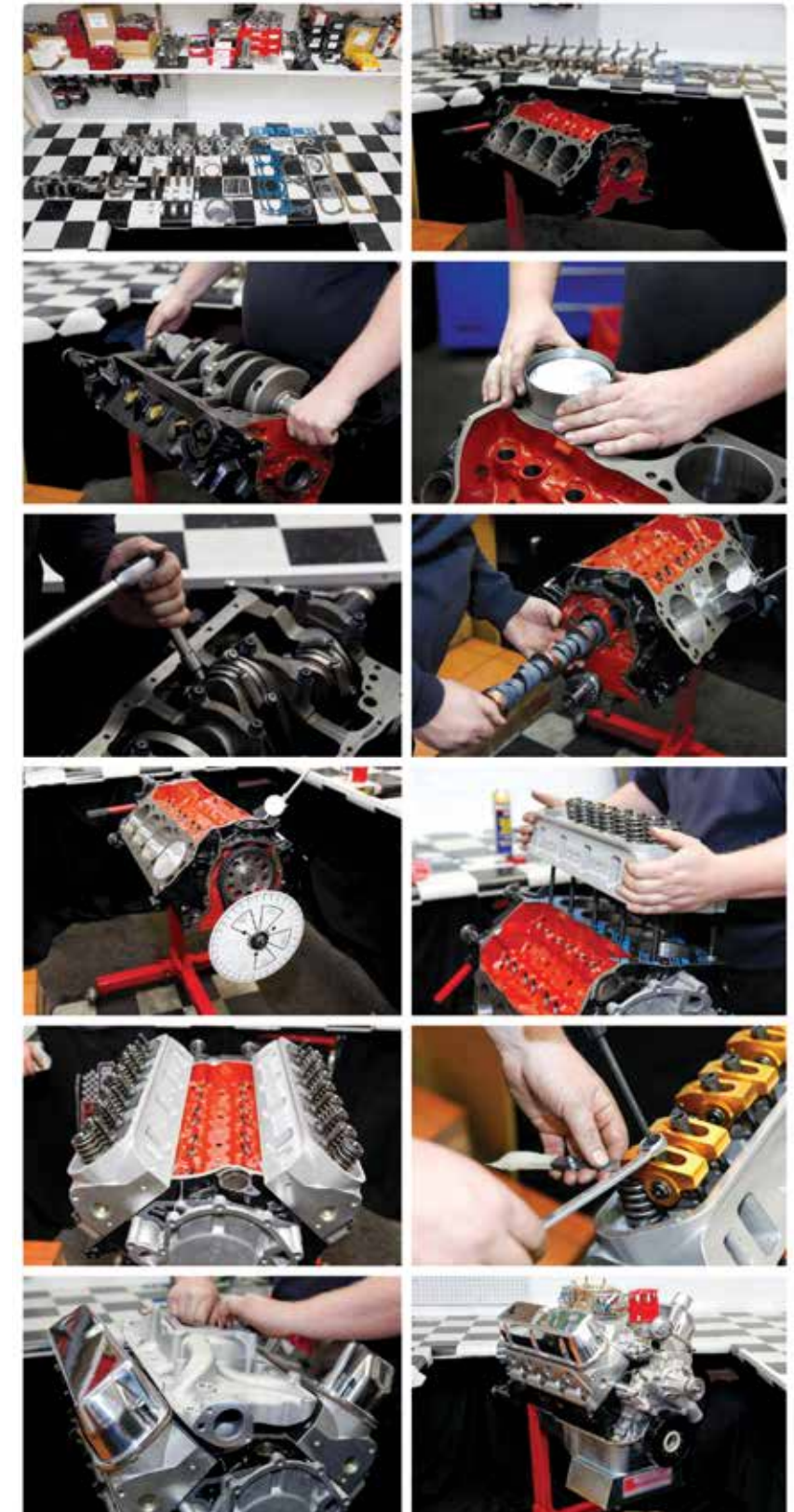

STRIP at LAS VEGAS

SPEEDMASTER 79

79

GOODYEAR

SAN'S
SPEEDMASTER



GREENWAY
TRIP

FEEL THE
ENERGY

99.99
99.99



Tools, Accessories & More



Every automotive enthusiast and professional mechanic knows that it's nearly impossible to get the job done without the right tools. That's why Speedmaster™ is your place to go for garage equipment, specialty tools, and everyday problem solvers.

Gauges & Accessories

Gauges, Analog

Speedmaster™ analog gauges are the perfect choice. A white dial face with performance-inspired graphics, a polished chrome bezel, and a classic domed lens reveal a look that truly reflects the American muscle style.

Proper fuel pressure is critical for adjusting your carburetor or fuel injection. These Speedmaster gauges come with a classic white face and are available in dry or liquid-filled designs, for accurate, steady readings. In addition, all gauges come with a 1/8 in. NPT male fitting.



Gauge Type	Gauge Range	Gauge Size (in)	Sweep	Gauge Face Color	Gauge Number Color	Pointer Color	Bezel Finish	Liquid-Filled	SKU
Fuel pressure	0-15 psi	1 1/2 in. diameter	Full sweep	White	Black	Black	Chrome	No	PCE357.1001
	0-100 psi	1 1/2 in. diameter	Full sweep	White	Black	Black	Chrome	Yes	PCE357.1003
Water temperature	0-280 degrees F	2 1/16 in. diameter	90 degree sweep	White	Black	Red	Chrome	No	PCE357.1005



Fluid Filled Pressure Gauges

When reading fuel pressure, keep in mind that a fluid filled pressure gauge will change its reading as the temperature of the gauge case changes (Under hood temperature). Because it's sealed to contain the liquid inside, a liquid filled gauge no longer compares line pressure to actual atmospheric pressure, reporting the difference. Instead, it compares line pressure to the pressure inside the gauge case. As the liquid in the case heats or cools, it expands and contracts, causing case pressure to change as much as 1 psi for every 30 degrees temperature change of the gauge.

Power Window Kits

Speedmaster™ power window conversion kits allow you to convert your old flat-glass windows into a completely new power system. Speedmaster™ revolutionary Super Glide window design ensures an easy installation and smooth operation. Each kit comes with high-torque motor, lower glass channel, GM switches, complete wire harness with switch, all of which ensure quick, quiet, and dependable operation for the life of your vehicle.

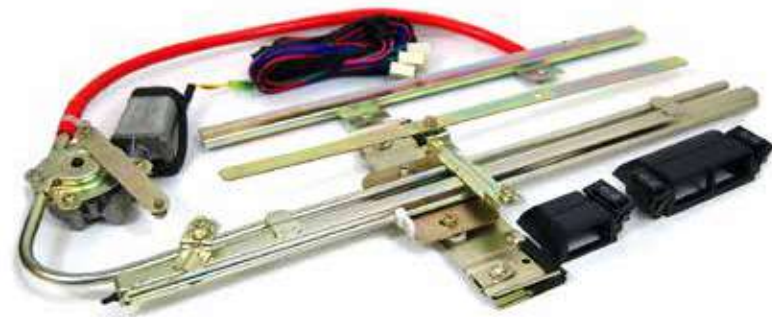

Switches Included	Switch Quantity	Relays Included	Wiring Harness Included	Window Actuation Style	Window Lockout Feature	Window Quantity	SKU
Yes	3 switches	No	Yes	Cable drive	No	2	PCE422.1001

Steering Columns

Speedmaster™ steering columns are chromed stainless steel, the wheel hub is aluminum and has a 9 Bolt GM Style wheel pattern. Most columns feature GM wiring, an emergency flasher, directionals, and 5-position tilt, and accept most aftermarket steering wheels. Each column is shipped with our 3-piece dress up kit, which consists of a tilt lever, a turn signal lever, and an emergency flasher knob, they also include the steering wheel adapter. The dress up kit pieces are machined from stainless steel and aluminum.



Ref.	Column Length (in)	Column Diameter (in)	Column Lower Output Shaft	Shifter Location	Ignition Key Location	Gear Indicator Included	Hazard Switch	Tilt	Turn Signal Switch Included	SKU
a.	33.000 in.	2.000 in.	1 in. DD	Column	Dash	Yes	Yes	Yes	Yes	PCE423.1001
b.	32.000 in.	2.000 in.	1 in. DD	Floor	Dash	No	Yes	Yes	Yes	PCE423.1002
c.	32.000 in.	2.000 in.	1 in. DD	Column	Column	Yes	Yes	Yes	Yes	PCE423.1003
d.	32.000 in.	2.000 in.	1 in. DD	Floor	Column	No	Yes	Yes	Yes	PCE423.1004

Steering Column Shift Arms

Speedmaster™ billet shifter arms are a great way to dress up your GM vehicle. With their billet aluminum construction and polished finish, they are a great way to put the finishing touches on your ride.



Application	Shifter Arm Material	Shifter Arm Finish	Notes	SKU
Chevrolet Gm 1964-94	Billet aluminum	Polished	Will not fit van steering columns.	PCE394.1001

Tools & Shop Equipment

Piston Ring Compressors

Now you can install your pistons with the ease of fixed ring compressors and the versatility of adjustable band compressors. These Speedmaster™ adjustable piston ring compressors have adjustability to fit most engine builders needs. The tapered aluminum design makes installation easy, and the worm clamp speeds up adjustment.



Adjustable	Piston Ring Compressor Material	Piston Ring Compressor Finish	SKU
Yes - 4.000 in. to 4.060 in.	Aluminum	Black anodized	PCE428.1001
Yes - 4.125 in. to 4.185 in.	Aluminum	Blue anodized	PCE428.1002
Yes - 4.250 in. to 4.310 in.	Aluminum	Red anodized	PCE428.1003

Oil Pump Primers

Those first moments that an engine runs prior to building oil pressure are when damage can easily occur. Speedmaster™ oil pump primer kits let you spin the oil pump with a drill motor and bring up the oil pressure prior to starting the engine. This prevents unnecessary wear or damage to rotating, reciprocating, and valvetrain components. Speedmaster™ rugged primer shafts are rated at 170,000 psi to ensure extended service life. They also feature a special billet aluminum sleeve that accurately positions the shaft and keeps it from wobbling. Speedmaster oil pump primers make it easy to get oil to the top of your engine. They are designed to fit in your distributor hole and require no modifications to use. They feature a billet aluminum adjustable collar and black oxide coated steel shaft.



PCE400.1001 Chevrolet SBC 350 BBC 454

Pushrod Length Checkers

Speedmaster™ pushrod length checking tools are precision crafted from steel alloy for years of accurate measurements. Speedmaster™ offers these pushrod length checkers as easy and economical tools to lay out and determine proper pushrod length for proper valvetrain geometry. This is necessary to obtain the desired results from the cam and ensure that damage is not done to the rest of the valvetrain. Made from a 3/8 in. pushrod that is cut and threaded with over 1 in. of travel, they have a 3/8 in. ball tip on both ends.



Maximum Pushrod Length	Minimum Pushrod Length	SKU
7.300 in.	5.800 in.	PCE401.1001
8.500 in.	7.000 in.	PCE401.1002
8.300 in.	7.800 in.	PCE401.1003
9.600 in.	8.400 in.	PCE401.1004

Crankshaft Sockets

Speedmaster™ crankshaft turning sockets are a necessity for engine building. These steel black oxide sockets are available for several applications to assist you in turning the crank while adjusting valve lash and piston-to-valve clearance. Give your engine build a good turn with help from Speedmaster crankshaft turning sockets.



Application	Socket Drive	Socket Material	Socket Finish	SKU
Chevrolet SBC 265 283 305 327 350 Holden 253 304 308	1/2 in.	Steel	Black oxide	PCE397.1001
Chevrolet BBC 366 396 402 427 454	1/2 in.	Steel	Black oxide	PCE397.1002
Ford SB 289 302 351W Windsor 351C Cleveland	1/2 in.	Steel	Black oxide	PCE397.1003

Degree Wheels

Speedmaster™ universal degree wheels are designed for the normal rebuild. They accurately measure camshaft centerline, valve timing, TDC, and BDC. Made from heavy-gauge metal with a silkscreen finish for long-lasting use, they include an adapter to fit virtually any engine.



Degree Wheel Diameter (in)	Degree Wheel Material	Degree Wheel Finish	Number Color	SKU
10.000 in.	Steel	Black	White	PCE398.1001

Engine Port Block Off Kits

Made of strong and durable plastic, these Speedmaster™ engine block-off kits protect your engine by blocking off open ports during storage or as a work in progress. These kits keep dirt and debris from entering various inlets and outlets on your engine.

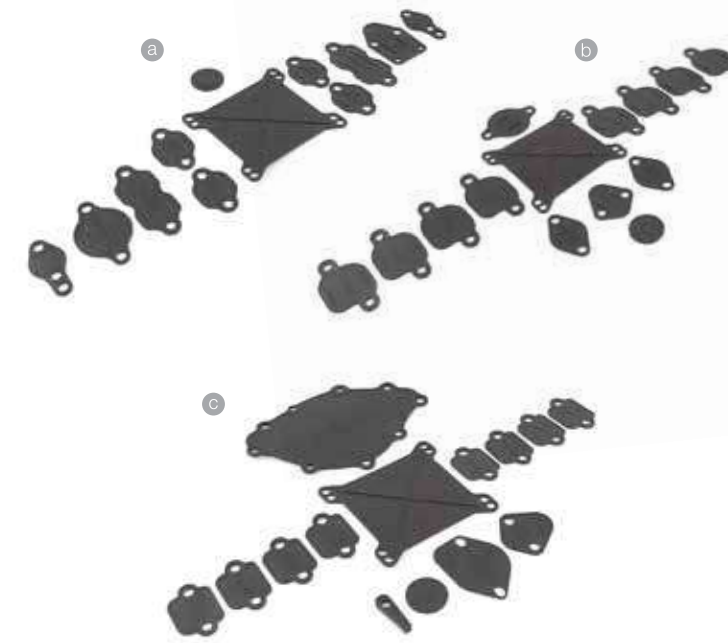

Application	Block Off Type	SKU
Chevrolet SBC 350	(a.) Complete Engine	PCE399.1001
	Water Neck Only	PCE399.1002
	Exhaust Port Single Only	PCE399.1003
	Exhaust Port Dual Only	PCE399.1004
	Fuel Pump Only	PCE399.1005
	Water Pump Only	PCE399.1006
	Distributor Only	PCE399.1007
Chevrolet BBC 454	(b.) Complete Engine	PCE399.1008
	Water Neck Only	PCE399.1009
	Exhaust Port Only	PCE399.1010
	Fuel Pump Only	PCE399.1011
	Water Pump Only	PCE399.1012
	Distributor Only	PCE399.1013
Ford SB 289 302 351W Windsor	(c.) Complete Engine	PCE399.1014
	Water Neck Only	PCE399.1015
	Exhaust Port Only	PCE399.1016
	Fuel Pump Only	PCE399.1017

Tools & Shop Equipment

Tire Pressure Gauges

Not sure what your tire pressure is? You'll never have to wonder again with one Speedmaster™ tire pressure gauges. Available in different styles to suit your needs.



Tire Pressure Gauge Type	Gauge Range	Gauge Size (in)	Hose Length (in)	Bleed Valve	SKU
Analog	0-15 psi	2 in. diameter	12	Yes	PCE395.1001
Analog	0-60 psi	2 in. diameter	12	Yes	PCE395.1002

Ignition Testers

Speedmaster™ ignition testers allow you to check the entire ignition system while it is in the car. Once the ignition tests good, you can continue troubleshooting and find the culprit. They produce a simulated trigger signal that fires the ignition just as if the engine were running. If the spark is unable to jump the gap of the tester, there is an ignition problem and you can trace it down. The testers operate on 4, 6, or 8-cylinder engines and will simulate up to 10,000 rpm.



PCE396.1001 Inductive and CDI Ignition Mouldle Tester (Rpm Simulator)

AN Hose End Wrenches

Doing any work on your ride is a lot easier and more pleasant when you have the right tools for the job. These heat-treated aluminum AN hose end wrench from Speedmaster™ are the perfect mates for working with aluminum AN hose ends to help prevent marring and are must-haves for your toolbox. They are made from quality anodized aluminum, include short handles to avoid over-tightening and designed them a special size to provide a comfortable grip; plus, the handles are stamped with the wrench size for easy identification, with Speedmaster AN hose end wrench sets, you're sure to have the size that you need for your job.

Speedmaster™ AN adjustable wrenches work with aluminum fittings, this Speedmaster CNC-machined billet aluminum adjustable ergonomic grip spanners are the ideal tool for your kit. Tighten or loosen -3AN to -12AN aluminum fittings in a hurry. Anodized for durability.



AN Wrench size	AN Wrench Finish	SKU
Set of 7	All	PCE402.1002
-3 AN & -4 AN	Green anodized	PCE403.1007
-4 AN & -6 AN	Silver anodized	PCE403.1008
-6 AN & -8 AN	Black anodized	PCE403.1009
-8 AN & -10 AN	Blue anodized	PCE403.1010
-10 AN & -12 AN	Purple anodized	PCE403.1011
-12 AN & -16 AN	Red anodized	PCE403.1012
16 AN & -20 AN	Golden anodized	PCE403.1013
Adjustable -3 An to -12 AN	Red anodized	PCE404.1001



Engine Lift Plates

Speedmaster™ engine lift plates will allow you to lift your engine up by its intake manifold for easier maneuvering. You can also use them as a manifold cover when you store your engine. These lift plates fit most 4-barrel intake manifolds.



Application	Lift Plate Material	Lift Plate Finish	SKU
Universal 4 Barrel Intake Manifold	Aluminum	Natural	PCE406.1001
Universal 4 Barrel Intake Manifold	Steel	Red powdercoated	PCE406.1002

Engine Stands

Leg Stand

Speedmaster™ engine stands are constructed from high-quality steel tubing, the mount brackets are 1/4 inch steel plate with pre-drilled holes that match; the motor mount pattern welded to tubular steel supports. Tube steel featuring solid welds on all joints and plastic end caps are included. Red powdercoat finish for protection. They have been specially designed to clear most oversized dry sump oil pans with up to 9 in. deep sumps.

Rotable Head Stand

Speedmaster™ Rotable head engine stands are designed to be used to position engines that need to be repaired or rebuilt. They feature a 63 to 1 ratio gearbox that easily rotates engines to your desired position by turning a crank handle. They have a fully adjustable mounting head and adapter fingers, as well as a space-saving folding design that's great for storage. If you're in the market for an engine stand, Speedmaster™ has the quality and dependability you'd expect from an engine stand.

Run in Stand

Speedmaster™ engine run and test stands are must-haves for the serious engine builder. These stands are fully adjustable to conform to any engine block. The front frame is designed to accommodate large radiators and their heavy-wall, welded steel frame is designed tough for high-output engines.



Style	Application	Caster	Weight Capacity (lbs)	SKU
2 Leg Stand	Chevrolet SBC 350 BBC 454	No	-	PCE407.1001
	GM LS LS1 LS2 LS3 LS6 LS7			PCE407.1009
	Ford 289 302 351W Windsor 351C Cleveland			PCE407.1002
4 Leg Cradle Stand	Chevrolet SBC 350 BBC 454	No	-	PCE407.1003
		Yes	-	PCE407.1007
Rotable Head Stand	Universal	Yes	750	PCE407.1004
			1000	PCE407.1005
Run in Stand	Universal	Yes	1250	PCE407.1006
			-	PCE407.1008

SPEEDMASTER™
EST. 1979



We Transform Matter into
High Performance Parts

Articles

Valve Train Geometry

As cam profiles continue to get more aggressive and valve springs pressure increase, the importance of pushrod knowledge has never been more critical. Here are some answers to the most common questions that you might have for Speedmaster™ tech support about pushrods.

Pushrod Length & Rocker Arm Geometry

A large number of variables are involved in determining the correct length pushrod for your application. Pushrod length is affected by any of the following:

- Block deck height
- Head deck height
- Head stud boss height
- Rocker arm brand/design
- Cam base circle size
- Lifter design/brand/pushrod seat height
- Valve stem length

Don't assume anything when determining the right pushrod for your new engine. A pushrod that fits one engine may not necessarily work in another. Any number of items can be different on your engine, requiring you to use a different pushrod length. Following the steps below will streamline the pushrod selection process, ensuring that you get the right parts the first time.

1. Buy a checking pushrod.

Do not buy pushrods when you buy the cam, lifters and other valve train components. As much as we would like to sell you pushrods at this time, nobody can predict ahead of time what length a given engine needs, unless it is bone stock.

Instead, invest in a checking pushrod at this time. They are available in two different designs, with the more expensive of the two being easier to measure once you have it adjusted to the proper length for your valve train. Neither is particularly expensive if you consider time lost and freight costs when returning pushrods.

Other companies offer their own versions of pushrod length checking devices, funny little plastic things with complicated instructions to calculate the length. The main disadvantage with these is that you have to order the pushrods and receive them before you know if your calculations are correct. With a checking pushrod, you can actually rotate the motor over and check the rocker arm/valve tip relationship as you adjust the pushrod length. When you get the correct geometry, it is a simple matter then to measure the length and place an order. Speedmaster™ carries a large number of various length and diameter pushrods so you get the correct length the first time.

2. Determine correct valve train geometry.

What is the correct length pushrod for your application? The one that produces correct valve train geometry. What is correct valve train geometry? When the rocker arm roller tip rolls from the intake side of the valve tip, across the center of the tip (at approximately mid-lift), to the exhaust side of the valve tip (at full lift) and back. See Diagram A.

3. Measure the resulting pushrod.

Measuring the length of a pushrod is a simple process. The most important thing to remember is that different manufacturers measure pushrods differently. Not all pushrods of a stated length will measure exactly the same. The three most common pushrod measurements are shown in Diagram B.

Theoretical Length: This assumes that the pushrod has no oil hole in the end of it. Therefore, the radius at either end is complete, which lengthens the pushrod approximately .017" in the case of a 5/16" pushrod with .100" diameter oil holes, minimally chamfered.

Actual Length: This is what you would measure if you had a set of calipers large enough to measure over the oil holes at each end of the pushrod. This is the measurement that most people can relate to. Unfortunately, this measurement is affected not only by the diameter of the oil holes but also by the entrance chamfer for each oil hole.

Gauge Length: Although the most difficult to measure (it requires a special length checking gauge), this measurement is the most reliable. This is because the oil holes and their chamfers are eliminated from the measurement. The only problem is that not all companies use the same gauge diameter. Speedmaster™ uses a .140" gauge diameter. All Magnum and Hi-Tech™ Pushrods listed in this catalog are measured using this technique. See Diagram B on the following page.

4. Simple measurement techniques.

We realize that most people don't have access to the special gauge required for these measurements or even a dial caliper large enough for most pushrods. We've developed two techniques to help you determine exact pushrod length so that the perfect valve train geometry is achieved in your engine.

Diagram A

1. Base Circle
2. Mid Lift
3. Max lift

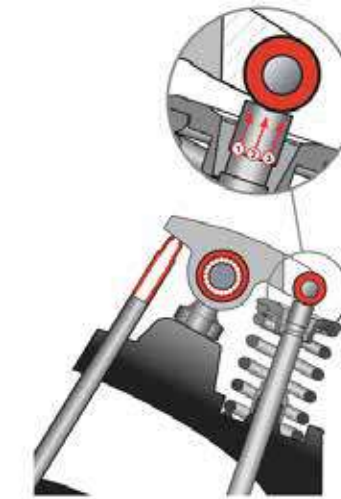

Pushrod Measurement Techniques

Technique #1

This technique requires the use of a Speedmaster™ Pushrod Length Checker. These are marked with a standard length stamped in them. This number represents the gauge length of the part (.140" gauge diameter) with the two halves screwed completely together. Extending the pushrod one rotation lengthens the gauge length .050". For example, a pushrod stamped 7.800 and screwed apart one rotation would be $7.800 + .050 = 7.850$ " gauge length. Therefore you would order the part number from the catalog that matches this gauge length, since gauge length is how they are listed.

Technique #2

This technique requires one of our Magnum Pushrod Length Checkers. Once fixed, you don't need to have an expensive gauge or a pair of calipers to measure it. You just need a pushrod of a known length to compare it to (a standard). Then use a pair of common 6" calipers to measure the difference between the standard and yours.

Here are a few final hints about pushrods in general. It is always a good idea to buy a few spares when purchasing a set of custom length pushrods, and stick them in your toolbox. If one ever fails at the track and you need a replacement, it would be nearly impossible to borrow one from a fellow racer.

Another hint involves cup end pushrods. Measuring them for length is especially difficult, no matter which technique above you choose to use. The size and shape of the cup end varies greatly from manufacturer to manufacturer, so measuring from the ball end to the cup end over the cup surface is a dangerous practice. The best strategy is to drop a 5/16" diameter steel ball into the cup end, and do all measuring over this ball, subtracting the 5/16" diameter (.3125") to figure the length.

Diagram B

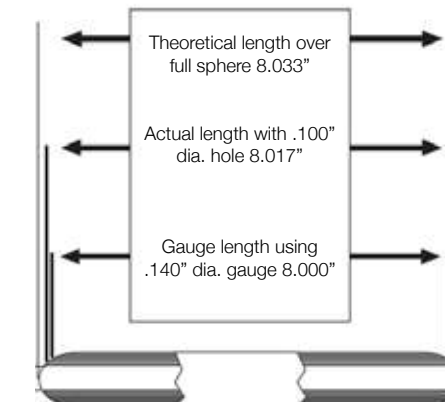

Featured Articles in Magazines

Magazine:
Muscle Mustangs & Fast Fords

Title: **Hidden Horsepower**

Article: Speedmaster™ block, rotating assembly, and heads are put to the test for extreme power levels.

1,037 hp @ 6,000 Rpm
957 lb-ft at 5,100 Rpm

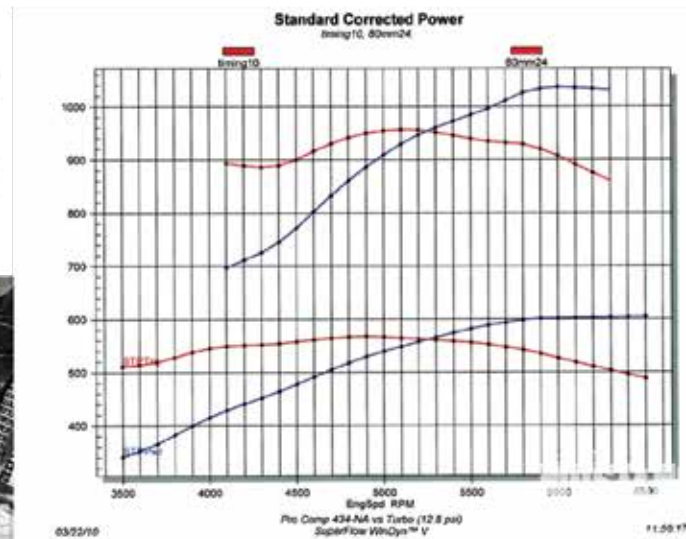

“ Despite the stress, the Speedmaster™ block, rotating assembly, and heads; impressed us with the ability to support these extreme power levels. ”



Magazine:
Truckin

Title: **Displacement & Replacement**

Article: 5.3L 383 Stroker Engine Build
Parts Used: 4.00-inch Forged steel stroker crank & 6.2-inch forged steel rods.
Results: 671 HP at 5,800 rpm and 658 lb-ft of tq at 4,600 RPM.



Magazine:
Super Chevy

Title: **Shes a Spinner**

Article: z/28 302 engine build & dyno test
Parts Used: forged crank and rods
Results: 519 hp 7,400 rpm



Magazine:
Super Chevy

Title: **Powerful Descision**

Article: LS1 Chevy Crate Engine Options
Parts Used: Forged-steel crank (4.0-inch) & 4340 (6.20-inch) rods.
Results: 506 hp and 503 lb-ft of tq.



Magazine:
Muscle Mustangs & Fast Fords

Title: **Hidden Horsepower**

Article: Add power to your small block with a simple oil sustem upgrade
Parts Used: 3.4-inch-stroke steel crank, 5.4-inch forged rods, oil pump, 8mm plug wires and a complete gasket set.
Results: 486 hp 6,600RPM & 421b-ft of Tq 4,800RPM



Magazine:
Vette

Title: **Clash of the small block Titans**

Article: 1970 LT1 Takes on 1996 LT-1 in a 350 cube throwdown.
Parts Used: Forged crank and rods.
Results: 353 hp at 5,600 rpm - 392 lb-ft at 4,100 rpm

Editorials

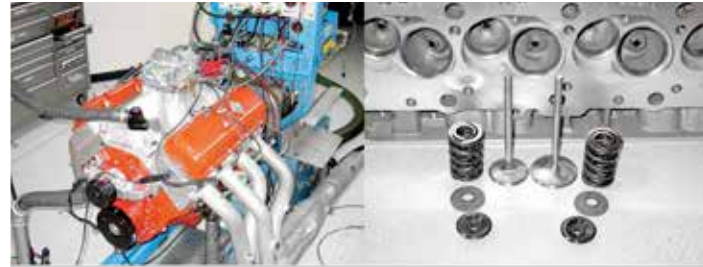

Magazine:
Super Chevy

Title: **454 Big block budget engine build**

Article: Super chevy builds a 700HP 454
Parts Used: Gaskets, Head studs kit, Complete BBC heads, adjustable guide plates, 1.7 ratio aluminum roller rockers, intake manifold.
Results: 736 hp and 691 lb-ft of torque



Magazine:
Popular Hot Rodding

Title: **Street scorcher small block**

Article: Building a 577HP 407 Chevy for street
Parts Used: CNC-ported cylinder heads
Results: 577 hp @ 6,100RPM and 538 lb-ft of torque @ 4,600



Magazine:
5.0 Mustang & Super Fords

Title: **Build a 347 for Half the Price of an all-out race engine**

Article: Building a budget 347 stroker
Parts Used: Aluminum cnc cylinder heads, stainless steel valves, manifold, distributor
Results: 500hp

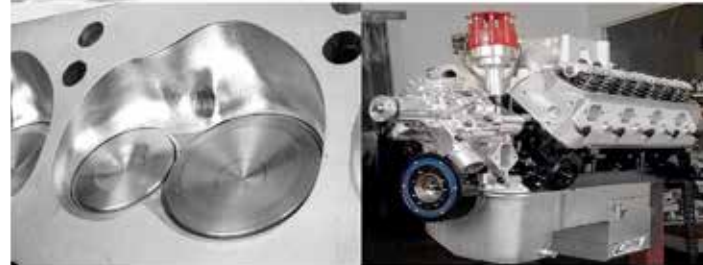

Magazine:
Muscle Mustang & Fast Fords

Title: **King of a Cleveland**

Article: Build a 500HP with affordable aluminum headed 400M
Parts Used: CNC Cleveland aluminum heads, stainless steel valves, springs, retainers & keepers – complete head package, gasket set & roller-tip rockers.
Results: 568hp and 542 lb-ft of torque.



Magazine:
Classic Trucks

Title: **Affordable Horse Power**

Article: Slow Budget Chevy 350 Small Block Engine Build
Parts Used: Aluminum cylinder heads, gasket kit, Dual-Plane Manifold, Roller rocker arms.
Results: 418 hp at 5,500 rpm 444 lb-ft of tq at 3,800 rpm.



Magazine:
Super Chevy

Title: **Style & Speed**

Article: deliver a 400 HP engine under \$1000!
Parts Used: 190 aluminum cylinder heads & aluminum valve covers.
Results: 350 pumped out 407 hp at 5800rpm & 410 lb ft of torque at 5400 rpm.



Magazine:
Muscle Mustangs & Fast Fords

Title: **Style & Speed**

Article: How to make 400HP for \$1000.
Parts Used: 210 as cast Cylinder heads, gasket set & roller-tip rockers.
Results: 302 Pumped out 399HP @6000RPM & 363 lb-ft of torque @5200 RPM



Magazine:
Truckin

Title: **Stroke it.**

Article: M&R Engines do a "Step by Step" How to build a chevy 383ci stroker
Parts Used: 190cc Alum. Cylinder heads, Steel Spring Seat Set, Roller Rocker Arms 1.5x 3/8, 3321 Alum. Timing Cover & HEI Distributor

Editorials

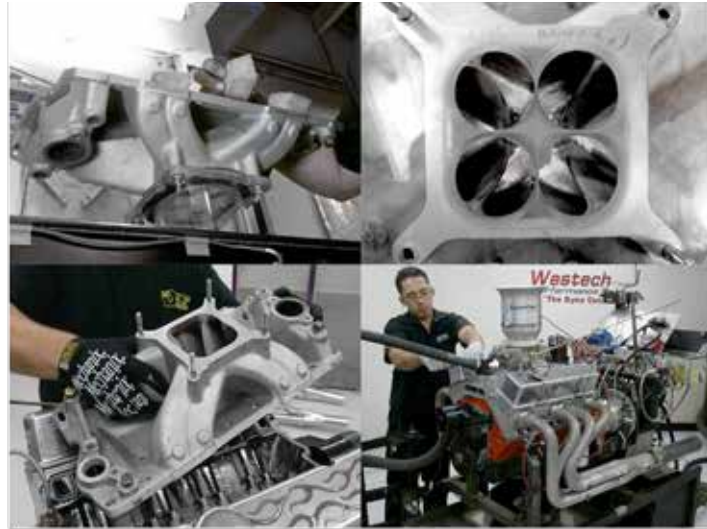

Magazine:
Engine Masters

Title: **Manifold Magic**

Article: Intake testing and modification for maximum power.
Parts Used: Single plenum manifold
Results:

Runner	2	4	6	8
As-Cast	300	254	210	294
Ported	352	334	314	356



Magazine:
Super Chevy

Title: **Action Packed Big Block test**

Article: Complete Chevy Big Block build and testing.
Parts Used: Dual plane intake manifold & billet distributor.
Results: 527 hp and 533 lb-ft of torque.

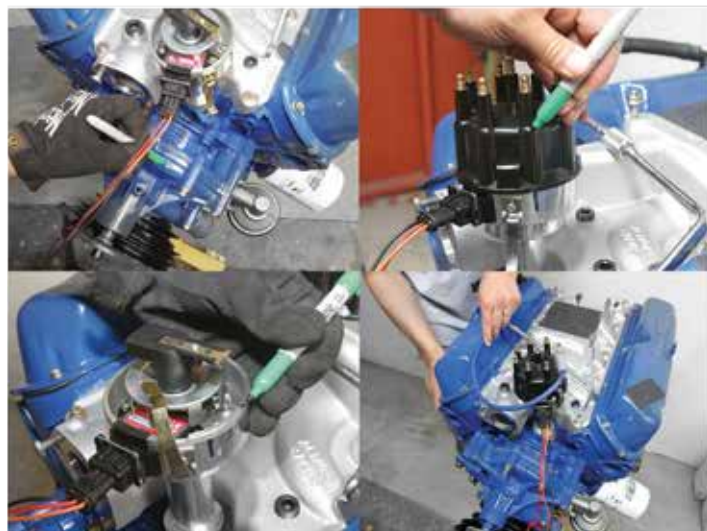

Magazine:
Car Craft Magazine

Title: **How to Stab a Distributor**

Article: Learn how to stab a distributor.
Parts Used: Speedmaster Distributor.



Magazine:
GM High Tech Performance

Title: **Inches and Pounds**

Article: Turbo - Boost comparisons between a Speedmaster™ 383 engine and a standard GM Chevy L98
Parts Used: Complete 383 Crate Motor.
Results:

L98 Standard

HP: 331
TQ: 394

L98 Turbo 7PSI

HP: 481
TQ: 579

Speedmaster™ 383 Standard

HP: 383
TQ: 457

Speedmaster™ 383 Turbo 6.9 PSI

HP: 712
TQ: 673

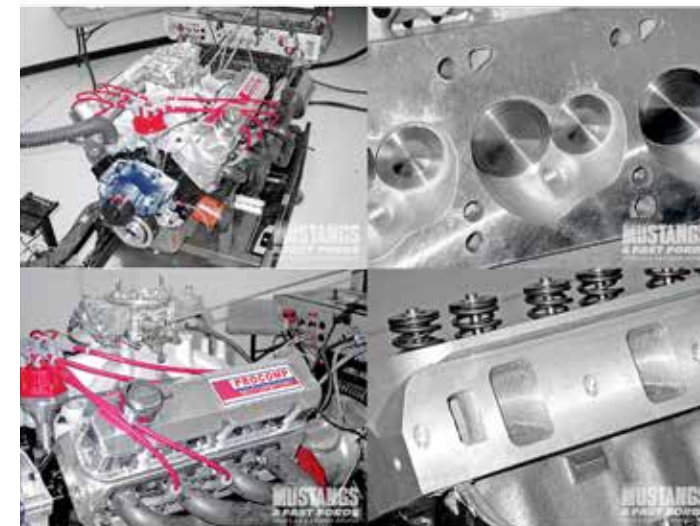

Magazine:
Muscle Mustangs & Fast Fords

Title: **Budget Brute**

Article: Test two Speedmaster™ cylinder heads; one as cast and one CNC on a 408 stroker.
Parts Used: As Cast Cylinder heads. 190cc Intake Ports. 258CFM @0.700 Lift

CNC Cylinder heads. 215cc intake ports. 300CFM @0.700 lift.

Results:

Equipped with the as-cast aluminum heads the 408 stroker produced 463HP and 480 lb-ft of TQ

Equipped with the CNC aluminum heads the 408 stroker produced 505HP and 489 lb-ft of TQ



Magazine:
Street Machine

Title: **308 to 355ci Stroker motor build Up**

Article: 308 to 355ci stroker build up.
Parts Used: Carburetor to oil Pan, full stroker Crate Motor.
Results: 456.7HP @ 6000RPM